



# Tazewell County Highway Department

## AUTHORIZATION TO BID FORM

Addenda will be published to our Bid Letting page in the same manner as the plans and specifications. It is the sole responsibility of the plan holders to periodically check the website for plan addenda.

**ALL BIDDERS PLANNING TO PLACE A BID MUST FILL OUT THIS FORM TO BE AUTHORIZED TO BID.**

- This form must be completed, signed and either faxed to (309) 925-5533 or emailed to [jsciortino@tazewell-il.gov](mailto:jsciortino@tazewell-il.gov).
- Failure to submit this completed form will result in the bid not being accepted.
- Contractors may verify we have received their Authorization to Bid form by checking the **Plan Holders List** found under the corresponding letting date.
- If an email address is provided, a Notice of Addenda will be sent when updates are available.
- Bid results are typically posted by noon on the day of the letting and are preliminary until approved by the County Board on the last Wednesday of the month.

Company Name:	
Address:	
Phone:	
Fax:	
Email:	
Bid Letting Date:	

### Projects Intending to Bid on:

Section Number:	Description:



COVER SHEET

Proposal Submitted By:

Contractor's Name

[Empty text box for Contractor's Name]

Contractor's Address

[Empty text box for Contractor's Address]

City

[Empty text box for City]

State

[Empty text box for State]

Zip Code

[Empty text box for Zip Code]

STATE OF ILLINOIS

Local Public Agency

Morton Road District

County

Tazewell

Section Number

24-14000-03-GM

Route(s) (Street/Road Name)

TR 71-A Broadway Road

Type of Funds

Township Non-MFT Funds

Proposal Only  Proposal and Plans  Proposal only, plans are separate

Submitted/Approved

For Local Public Agency:

For a County and Road District Project

Submitted/Approved

Highway Commissioner Signature & Date

Darrell Moore

Digitally signed by Darrell Moore  
Date: 2024.03.13 13:06:45  
-05'00'

Submitted/Approved

County Engineer/Superintendent of Highways Signature & Date

Dan Parr

Digitally signed by Dan Parr  
Date: 2024.03.13 13:07:42  
-05'00'

For a Municipal Project

Submitted/Approved/Passed

Signature & Date

[Empty text box for Signature & Date]

Official Title

[Empty text box for Official Title]

Department of Transportation

Released for bid based on limited review

Regional Engineer Signature & Date

[Empty text box for Regional Engineer Signature & Date]

Note: All proposal documents, including Proposal Guaranty Checks or Proposal Bid Bonds, should be stapled together to prevent loss when bids are processed.

Local Public Agency	County	Section Number	Route(s) (Street/Road Name)
Morton Road District	Tazewell	24-14000-03-GM(N-MFT)	TR 71-A Broadway Road

### NOTICE TO BIDDERS

Sealed proposals for the project described below will be received at the office of the Tazewell County Engineer

<u>21308 Illinois Route 9</u>	<u>Tremont, Illinois 61568</u>	Name of Office	
Address	Address	until <u>1:30 PM</u>	on <u>04/15/24</u>
		Time	Date

Sealed proposals will be opened and read publicly at the office of the Tazewell County Engineer

<u>21308 Illinois Route 9</u>	<u>Tremont, Illinois 61568</u>	Name of Office	
Address	Address	at <u>1:30 PM</u>	on <u>04/15/24</u>
		Time	Date

### DESCRIPTION OF WORK

Location	Project Length
TR 71-A Broadway Road	3,700 LF

Proposed Improvement
HMA SURF REM BUTT JT, HMA BC IL-9.5 N50 & HMA SC IL-9.5 C N50

1. Plans and proposal forms will be available in the office of

Tazewell County Engineer 21308 Illinois Route 9 Tremont, Illinois 61568
-------------------------------------------------------------------------------

2.  Prequalification  
If checked, the 2 apparent as read low bidders must file within 24 hours after the letting an "Affidavit of Availability" (Form BC 57) in triplicate, showing all uncompleted contracts awarded to them and all low bids pending award for Federal, State, County, Municipal and private work. One original shall be filed with the Awarding Authority and two originals with the IDOT District Office.
3. The Awarding Authority reserves the right to waive technicalities and to reject any or all proposals as provided in BLRS Special Provision for Bidding Requirements and Conditions for Contract Proposals.
4. The following BLR Forms shall be returned by the bidder to the Awarding Authority:
  - a. Local Public Agency Formal Contract Proposal (BLR 12200)
  - b. Schedule of Prices (BLR 12201)
  - c. Proposal Bid Bond (BLR 12230) (if applicable)
  - d. Apprenticeship or Training Program Certification (BLR 12325) (do not use for project with Federal funds.)
  - e. Affidavit of Illinois Business Office (BLR 12326) (do not use for project with Federal funds)
5. The quantities appearing in the bid schedule are approximate and are prepared for the comparison of bids. Payment to the Contractor will be made only for the actual quantities of work performed and accepted or materials furnished according to the contract. The scheduled quantities of work to be done and materials to be furnished may be increased, decreased or omitted as hereinafter provided.
6. Submission of a bid shall be conclusive assurance and warranty the bidder has examined the plans and understands all requirements for the performance of work. The bidder will be responsible for all errors in the proposal resulting from failure or neglect to conduct an in depth examination. The Awarding Authority will, in no case, be responsible for any costs, expenses, losses or changes in anticipated profits resulting from such failure or neglect of the bidder.
7. The bidder shall take no advantage of any error or omission in the proposal and advertised contract.
8. If a special envelope is supplied by the Awarding Authority, each proposal should be submitted in that envelope furnished by the Awarding Agency and the blank spaces on the envelope shall be filled in correctly to clearly indicate its contents. When an envelope other than the special one furnished by the Awarding Authority is used, it shall be marked to clearly indicate its contents. When sent by mail, the sealed proposal shall be addressed to the Awarding Authority at the address and in care of the official in whose office the bids are to be received. All proposals shall be filed prior to the time and at the place specified in the Notice to Bidders. Proposals received after the time specified will be returned to the bidder unopened.
9. Permission will be given to a bidder to withdraw a proposal if the bidder makes the request in writing or in person before the time for opening proposals.

Local Public Agency	County	Section Number	Route(s) (Street/Road Name)
Morton Road District	Tazewell	24-14000-03-GM(N-MFT)	TR 71-A Broadway Road

**PROPOSAL**

1. Proposal of \_\_\_\_\_ Contractor's Name \_\_\_\_\_

Contractor's Address \_\_\_\_\_

2. The plans for the proposed work are those prepared by the Tazewell County Highway Department and approved by the Department of Transportation on \_\_\_\_\_.

3. The specifications referred to herein are those prepared by the Department of Transportation and designated as "Standard Specifications for Road and Bridge Construction" and the " Supplemental Specifications and Recurring Special Provisions" thereto, adopted and in effect on the date of invitation for bids.

4. The undersigned agrees to accept, as part of the contract, the applicable Special Provisions indicated on the "Check Sheet for Recurring Special Provisions" contained in this proposal.

5. The undersigned agrees to complete the work within \_\_\_\_\_ working days or by 09/01/24 unless additional time is granted in accordance with the specifications.

6. The successful bidder at the time of execution of the contract Will be required to deposit a contract bond for the full amount of the award. When a contract bond is not required, the proposal guaranty check will be held in lieu thereof. If this proposal is accepted and the undersigned fails to execute a contract and contract bond as required, it is hereby agreed that the Bid Bond of check shall be forfeited to the Awarding Authority.

7. Each pay item should have a unit price and a total price. If no total price is shown or if there is a discrepancy between the products of the unit price multiplied by the quantity, the unit price shall govern. If a unit price is omitted, the total price will be divided by the quantity in order to establish a unit price. A bid may be declared unacceptable if neither a unit price nor a total price is shown.

8. The undersigned submits herewith the schedule of prices on BLR 12201 covering the work to be performed under this contract.

9. The undersigned further agrees that if awarded the contract for the sections contained in the combinations on BLR 12201, the work shall be in accordance with the requirements of each individual proposal for the multiple bid specified in the Schedule for Multiple Bids below.

10. A proposal guaranty in the proper amount, as specified in BLRS Special Provision for Bidding Requirements and Conditions for Contract Proposals, will be required. Bid Bonds Will be allowed as a proposal guaranty. Accompanying this proposal is either a bid bond, if allowed, on Department form BLR 12230 or a proposal guaranty check, complying with the specifications, made payable to: Morton Township Supervisor, \_\_\_\_\_ .  
The amount of the check is \_\_\_\_\_ ( \_\_\_\_\_ ).

**Attach Cashier's Check or Certified Check Here**

In the event that one proposal guaranty check is intended to cover two or more bid proposals, the amount must be equal to the sum of the proposal guaranties which would be required for each individual bid proposal. If the proposal guaranty check is placed in another bid proposal, state below where it may be found.

The proposal guaranty check will be found in the bid proposal for: Section Number \_\_\_\_\_ .

Local Public Agency	County	Section Number	Route(s) (Street/Road Name)
Morton Road District	Tazewell	24-14000-03-GM(N-MFT)	TR 71-A Broadway Road

## CONTRACTOR CERTIFICATIONS

The certifications hereinafter made by the bidder are each a material representation of fact upon which reliance is placed should the Department enter into the contract with the bidder.

1. **Debt Delinquency.** The bidder or contractor or subcontractor, respectively, certifies that it is not delinquent in the payment of any tax administered by the Department of Revenue unless the individual or other entity is contesting, in accordance with the procedure established by the appropriate Revenue Act, its liability for the tax or the amount of the tax. Making a false statement voids the contract and allows the Department to recover all amounts paid to the individual or entity under the contract in a civil action.
2. **Bid-Rigging or Bid Rotating.** The bidder or contractor or subcontractor, respectively, certifies that it is not barred from contracting with the Department by reason of a violation of either 720 ILCS 5/33E-3 or 720 ILCS 5/33E-4.

A violation of section 33E-3 would be represented by a conviction of the crime of bid-rigging which, in addition to Class 3 felony sentencing, provides that any person convicted of this offense, or any similar offense of any state or the United States which contains the same elements as this offense shall be barred for 5 years from the date of conviction from contracting with any unit of State or local government. No corporation shall be barred from contracting with any unit of State or local government as a result of a conviction under this Section of any employee or agent of such corporation if the employee so convicted is no longer employed by the corporation: (1) it has been finally adjudicated not guilty or (2) if it demonstrates to the governmental entity with which it seeks to contract that entity finds that the commission of the offense was neither authorized, requested, commanded, nor performed by a director, officer or a high managerial agent on behalf of the corporation.

A violation of Section 33E-4 would be represented by a conviction of the crime of bid-rotating which, in addition to Class 2 felony sentencing, provides that any person convicted of this offense or any similar offense of any state or the United States which contains the same elements as this offense shall be permanently barred from contracting with any unit of State of Local government. No corporation shall be barred from contracting with any unit of State or Local government as a result of a conviction under this Section of any employee or agent of such corporation if the employee so convicted is no longer employed by the corporation and: (1) it has been finally adjudicated not guilty or (2) if it demonstrates to the governmental entity with which it seeks to contract and that entity finds that the commission of the offense was neither authorized, requested, commanded, nor performed by a director, officer or a high managerial agent on behalf of the corporation.

3. **Bribery.** The bidder or contractor or subcontractor, respectively, certifies that, it has not been convicted of bribery or attempting to bribe an officer or employee of the State of Illinois or any unit of local government, nor has the firm made an admission of guilt of such conduct which is a matter or record, nor has an official, agent, or employee of the firm committed bribery or attempted bribery on behalf of the firm and pursuant to the direction or authorization of a responsible official of the firm.
4. **Interim Suspension or Suspension.** The bidder or contractor or subcontractor, respectively, certifies that it is not currently under a suspension as defined in Subpart I of Title 44 Subtitle A Chapter III Part 6 of the Illinois Administrative code. Furthermore, if suspended prior to completion of this work, the contract or contracts executed for the completion of this work may be canceled.

Local Public Agency	County	Section Number	Route(s) (Street/Road Name)
Morton Road District	Tazewell	24-14000-03-GM(N-MFT)	TR 71-A Broadway Road

**SIGNATURES**

(If an individual)

Bidder Signature & Date

Business Address

City

State

Zip Code

(If a partnership)

Firm Name

Signature & Date

Title

Business Address

City

State

Zip Code

Insert the Names and Addresses of all Partners

(If a corporation)

Corporate Name

Signature & Date

Title

Business Address

City

State

Zip Code

Insert Names of Officers

President

Attest:

Secretary

Secretary

Treasurer



Contractor's Name

Contractor's Address

City

State

Zip Code

Local Public Agency

County

Section Number

Route(s) (Street/Road Name)

**Schedule for Multiple Bids**

Combination Letter	Section Included in Combinations	Total

**Schedule for Single Bid**

(For complete information covering these items, see plans and specifications.)

Item Number	Items	Unit	Quantity	Unit Price	Total
1	HMA SURF REM BUTT JT	SQ YD	330		
2	TEMPORARY RAMP	SQ YD	18		
3	P BIT MATLS TACK CT	POUND	12,862		
4	HMA BC IL-9.5 N50	TON	493		
5	HMA SC IL-9.5 C N50	TON	740		
6	INCIDENTAL HMA SURF	TON	18		
7	TRAF CONT & PROT SPL	L SUM	1		
<b>Bidder's Total Proposal</b>					

1. Each pay item should have a unit price and a total price.
2. If no total price is shown or if there is a discrepancy between the product of the unit price multiplied by the quantity, the unit price shall govern.
3. If a unit price is omitted, the total price will be divided by the quantity in order to establish a unit price.
4. A bid may be declared unacceptable if neither a unit price or total price is shown.





Local Public Agency Proposal Bid Bond

Local Public Agency: Morton Road District; County: Tazewell; Section Number: 24-14000-03-GM(N-MFT)

WE, \_\_\_\_\_ as PRINCIPAL, and \_\_\_\_\_ as SURETY, are held jointly, severally and firmly bound unto the above Local Public Agency (hereafter referred to as "LPA") in the penal sum of 5% of the total bid price, or for the amount specified in the proposal documents in effect on the date of invitation for bids, whichever is the lesser sum. We bind ourselves, our heirs, executors, administrators, successors, and assigns, jointly pay to the LPA this sum under the conditions of this instrument.

WHEREAS THE CONDITION OF THE FOREGOING OBLIGATION IS SUCH that, the said PRINCIPAL is submitting a written proposal to the LPA acting through its awarding authority for the construction of the work designated as the above section.

THEREFORE if the proposal is accepted and a contract awarded to the PRINCIPAL by the LPA for the above designated section and the PRINCIPAL shall within fifteen (15) days after award enter into a formal contract, furnish surety guaranteeing the faithful performance of the work, and furnish evidence of the required insurance coverage, all as provided in the "Standard Specifications for Road and Bridge Construction" and applicable Supplemental Specifications, then this obligation shall become void; otherwise it shall remain in full force and effect.

IN THE EVENT the LPA determines the PRINCIPAL has failed to enter into a formal contract in compliance with any requirements set forth in the preceding paragraph, then the LPA acting through its awarding authority shall immediately be entitled to recover the full penal sum set out above, together with all court costs, all attorney fees, and any other expense of recovery.

IN TESTIMONY WHEREOF, the said PRINCIPAL and the said SURETY have caused this instrument to be signed by their respective officers this \_\_\_\_\_ of \_\_\_\_\_ Day Month and Year

Principal signature block: Company Name, Signature & Date, Title

Principal signature block: Company Name, Signature & Date, Title

(If Principal is a joint venture of two or more contractors, the company names, and authorized signatures of each contractor must be affixed.)

Surety signature block: Name of Surety

Surety signature block: Signature of Attorney-in-Fact Signature & Date

STATE OF IL
COUNTY OF

I \_\_\_\_\_, a Notary Public in and for said county do hereby certify that

(Insert names of individuals signing on behalf of PRINCIPAL & SURETY)

who are each personally known to me to be the same persons whose names are subscribed to the foregoing instrument on behalf of PRINCIPAL and SURETY, appeared before me this day in person and acknowledged respectively, that they signed and delivered said instruments as their free and voluntary act for the uses and purposes therein set forth.

Given under my hand and notarial seal this \_\_\_\_\_ day of \_\_\_\_\_ Month and Year

(SEAL, if required by the LPA)

Notary Public Signature & Date

Date commission expires \_\_\_\_\_

Local Public Agency

County

Section Number

Morton Road District

Tazewell

24-14000-03-GM(N-MFT)

ELECTRONIC BID BOND

**Electronic bid bond is allowed (box must be checked by LPA if electronic bid bond is allowed)**

The Principal may submit an electronic bid bond, in lieu of completing the above section of the Proposal Bid Bond Form. By providing an electronic bid bond ID code and signing below, the Principal is ensuring the identified electronic bid bond has been executed and the Principal and Surety are firmly bound unto the LPA under the conditions of the bid bond as shown above. (If PRINCIPAL is a joint venture of two or more contractors, an electronic bid bond ID code, company/Bidder name title and date must be affixed for each contractor in the venture.)

Electronic Bid Bond ID Code

--	--	--	--	--	--	--	--	--	--	--	--	--	--	--	--	--	--	--	--	--

Company/Bidder Name

--

Signature & Date

--

Title

--



Bureau of Construction  
2300 South Dirksen Parkway/Room 322  
Springfield, IL 62764

Instructions: Complete this form by either typing or using black ink. "Authorization to Bid" will not be issued unless both sides of this form are completed in detail. Use additional forms as needed to list all work.

**Part I. Work Under Contract**

List below all work you have under contract as either a prime contractor or a subcontractor. It is required to include all pending low bids not yet awarded or rejected. In a joint venture, list only that portion of the work which is the responsibility of your company. The uncompleted dollar value is to be based upon the most recent engineer's or owners estimate, and must include work subcontracted to others. If no work is contracted, show NONE.

	1	2	3	4	Awards Pending	Accumulated Totals
Contract Number						
Contract With						
Estimated Completion Date						
Total Contract Price						
Uncompleted Dollar Value if Firm is the Prime Contractor						
Uncompleted Dollar Value if Firm is the Subcontractor						
Total Value of All Work						

**Part II. Awards Pending and Uncompleted Work to be done with your own forces.**

List below the uncompleted dollar value of work for each contract and awards pending to be completed with your own forces. All work subcontracted to others will be listed on the reverse of this form. In a joint venture, list only that portion of the work to be done by your company. If no work is contracted, show NONE.

Earthwork						
Portland Cement Concrete Paving						
HMA Plant Mix						
HMA Paving						
Clean & Seal Cracks/Joints						
Aggregate Bases, Surfaces						
Highway, R.R., Waterway Struc.						
Drainage						
Electrical						
Cover and Seal Coats						
Concrete Construction						
Landscaping						
Fencing						
Guardrail						
Painting						
Signing						
Cold Milling, Planning, Rotomilling						
Demolition						
Pavement Markings (Paint)						
Other Construction (List)						
Totals						

Disclosure of this information is REQUIRED to accomplish the statutory purpose as outlined in the "Illinois Procurement Code." Failure to comply will result in non-issuance of an "Authorization To Bid." This form has been approved by the State Forms Management Center.

**Part III. Work Subcontracted to Others.**

For each contract described in Part I, list all the work you have subcontracted to others.

	1	2	3	4	Awards Pending
Subcontractor					
Type of Work					
Subcontract Price					
Amount Uncompleted					
Subcontractor					
Type of Work					
Subcontract Price					
Amount Uncompleted					
Subcontractor					
Type of Work					
Subcontract Price					
Amount Uncompleted					
Subcontractor					
Type of Work					
Subcontract Price					
Amount Uncompleted					
Subcontractor					
Type of Work					
Subcontract Price					
Amount Uncompleted					
<b>Total Uncompleted</b>					

**Notary**

I, being duly sworn, do hereby declare this affidavit is a true and correct statement relating to ALL uncompleted contracts of the undersigned for Federal, State, County, City and private work, including ALL subcontract work, ALL pending low bids not yet awarded or rejected and ALL estimated completion dates.

Officer or Director

Title

Signature

Date

Company

Address

City

State

Zip Code

Subscribed and sworn to before me

this \_\_\_\_\_ day of \_\_\_\_\_, \_\_\_\_\_

\_\_\_\_\_  
(Signature of Notary Public)

My commission expires \_\_\_\_\_

(Notary Seal)

Add pages for additional contracts

Local Public Agency	County	Street Name/Road Name	Section Number
Morton Road District	Tazewell	TR 71-A Broadway Road	24-14000-03-GM(N-MFT)

**All contractors are required to complete the following certification**

- For this contract proposal or for all bidding groups in this deliver and install proposal.
- For the following deliver and install bidding groups in this material proposal.

Illinois Department of Transportation policy, adopted in accordance with the provisions of the Illinois Highway Code, requires this contract to be awarded to the lowest responsive and responsible bidder. The award decision is subject to approval by the Department. In addition to all other responsibility factors, this contract or deliver and install proposal requires all bidders and all bidder's subcontractors to disclose participation in apprenticeship or training programs that are (1) approved by and registered with the United States Department of Labor's Bureau of Apprenticeship and Training, and (2) applicable to the work of the above indicated proposals or groups. Therefore, all bidders are required to complete the following certification:

1. Except as provided in paragraph 4 below, the undersigned bidder certifies that it is a participant, either as an individual or as part of a group program, in an approved apprenticeship or training program applicable to each type of work or craft that the bidder will perform with its own employees.
2. The undersigned bidder further certifies, for work to be performed by subcontract, that each of its subcontractors either (A) is, at the time of such bid, participating in an approved, applicable apprenticeship or training program; or (B) will, prior to commencement of performance of work pursuant to this contract, establish participation in an approved apprenticeship or training program applicable to the work of the subcontract.
3. The undersigned bidder, by inclusion in the list in the space below, certifies the official name of each program sponsor holding the Certificate of Registration for all of the types of work or crafts in which the bidder is a participant and that will be performed with the bidder's employees. Types of work or craft that will be subcontracted shall be included and listed as subcontract work. The list shall also indicate any type of work or craft job category for which there is no applicable apprenticeship or training program available.

4. Except for any work identified above, if any bidder or subcontractor shall perform all or part of the work of the contract or deliver and install proposal solely by individual owners, partners or members and not by employees to whom the payment of prevailing rates of wages would be required, check the following box, and identify the owner/operator workforces and positions of ownership.

The requirements of this certification and disclosure are a material part of the contract, and the contractor shall require this certification provision to be included in all approved subcontracts. The bidder is responsible for making a complete report and shall make certain that each type of work or craft job category that will be utilized on the project is accounted for and listed. The Department at any time before or afterward may require the production of a copy of each applicable Certificate of Registration issued by the United States Department of Labor evidencing such participation by the contractor and any or all of its subcontractors. In order to fulfill the participation requirement, it shall not be necessary that any applicable program sponsor be currently taking or that it will take applications for apprenticeship, training or employment during the performance of the work of this contract or deliver and install proposal.

Bidder	Signature & Date		
<div style="border: 1px solid black; height: 20px;"></div>	<div style="border: 1px solid black; height: 40px;"></div>		
Title			
<div style="border: 1px solid black; height: 20px;"></div>			
Address	City	State	Zip Code
<div style="border: 1px solid black; height: 20px;"></div>	<div style="border: 1px solid black; height: 20px;"></div>	<div style="border: 1px solid black; height: 20px;"></div>	<div style="border: 1px solid black; height: 20px;"></div>



**Affidavit of Illinois Business Office**

Local Public Agency	County	Street Name/Road Name	Section Number
Morton Road District	Tazewell	TR 71-A Broadway Road	24-14000-03-GM(N-MFT)

I, \_\_\_\_\_ of \_\_\_\_\_, \_\_\_\_\_,  
Name of Affiant City of Affiant State of Affiant

being first duly sworn upon oath, state as follows:

1. That I am the \_\_\_\_\_ of \_\_\_\_\_.  
Officer or Position Bidder
2. That I have personal knowledge of the facts herein stated.
3. That, if selected under the proposal described above, \_\_\_\_\_, will maintain a business office in the  
Bidder  
 State of Illinois, which will be located in \_\_\_\_\_ County, Illinois.  
County
4. That this business office will serve as the primary place of employment for any persons employed in the construction contemplated by this proposal.
5. That this Affidavit is given as a requirement of state law as provided in Section 30-22(8) of the Illinois Procurement Code.

Signature & Date

Print Name of Affiant

**Notary Public**

State of IL

County \_\_\_\_\_

Signed (or subscribed or attested) before me on \_\_\_\_\_ by \_\_\_\_\_  
(date)

\_\_\_\_\_, authorized agent(s) of \_\_\_\_\_  
(name/s of person/s)

\_\_\_\_\_  
Bidder

Notary Public Signature & Date

My commission expires \_\_\_\_\_

(SEAL)

INDEX  
FOR  
SUPPLEMENTAL SPECIFICATIONS  
AND RECURRING SPECIAL PROVISIONS

Adopted January 1, 2024

This index contains a listing of SUPPLEMENTAL SPECIFICATIONS and frequently used RECURRING SPECIAL PROVISIONS.

ERRATA Standard Specifications for Road and Bridge Construction (Adopted 1-1-22) (Revised 1-1-24)

SUPPLEMENTAL SPECIFICATIONS

<u>Std. Spec. Sec.</u>	<u>Page No.</u>
202 Earth and Rock Excavation .....	1
204 Borrow and Furnished Excavation .....	2
207 Porous Granular Embankment .....	3
211 Topsoil and Compost .....	4
407 Hot-Mix Asphalt Pavement (Full-Depth) .....	5
420 Portland Cement Concrete Pavement .....	6
502 Excavation for Structures .....	7
509 Metal Railings .....	8
540 Box Culverts .....	9
542 Pipe Culverts .....	29
586 Granular Backfill for Structures .....	34
630 Steel Plate Beam Guardrail .....	35
644 High Tension Cable Median Barrier .....	36
665 Woven Wire Fence .....	37
782 Reflectors .....	38
801 Electrical Requirements .....	40
821 Roadway Luminaires .....	43
1003 Fine Aggregates .....	44
1004 Coarse Aggregates .....	45
1010 Finely Divided Minerals .....	46
1020 Portland Cement Concrete .....	47
1030 Hot-Mix Asphalt .....	48
1061 Waterproofing Membrane System .....	49
1067 Luminaire .....	50
1097 Reflectors .....	57

Local Public Agency	County	Section Number
Morton Road District	Tazewell	24-14000-03-GM(N-MFT)

**Check this box for lettings prior to 01/01/2024.**

The Following Recurring Special Provisions Indicated By An "X" Are Applicable To This Contract And Are Included By Reference:

Recurring Special Provisions

<u>Check Sheet #</u>		<u>Page No.</u>
1	<input type="checkbox"/> Additional State Requirements for Federal-Aid Construction Contracts	59
2	<input type="checkbox"/> Subletting of Contracts (Federal-Aid Contracts)	62
3	<input type="checkbox"/> EEO	63
4	<input type="checkbox"/> Specific EEO Responsibilities Non Federal-Aid Contracts	73
5	<input type="checkbox"/> Required Provisions - State Contracts	78
6	<input type="checkbox"/> Asbestos Bearing Pad Removal	84
7	<input type="checkbox"/> Asbestos Waterproofing Membrane and Asbestos HMA Surface Removal	85
8	<input type="checkbox"/> Temporary Stream Crossings and In-Stream Work Pads	86
9	<input type="checkbox"/> Construction Layout Stakes	87
10	<input type="checkbox"/> Use of Geotextile Fabric for Railroad Crossing	90
11	<input type="checkbox"/> Subsealing of Concrete Pavements	92
12	<input type="checkbox"/> Hot-Mix Asphalt Surface Correction	96
13	<input type="checkbox"/> Pavement and Shoulder Resurfacing	98
14	<input type="checkbox"/> Patching with Hot-Mix Asphalt Overlay Removal	99
15	<input type="checkbox"/> Polymer Concrete	101
16	<input type="checkbox"/> Reserved	103
17	<input type="checkbox"/> Bicycle Racks	104
18	<input type="checkbox"/> Temporary Portable Bridge Traffic Signals	106
19	<input type="checkbox"/> Nighttime Inspection of Roadway Lighting	108
20	<input type="checkbox"/> English Substitution of Metric Bolts	109
21	<input type="checkbox"/> Calcium Chloride Accelerator for Portland Cement Concrete	110
22	<input type="checkbox"/> Quality Control of Concrete Mixtures at the Plant	111
23	<input type="checkbox"/> Quality Control/Quality Assurance of Concrete Mixtures	119
24	<input type="checkbox"/> Reserved	135
25	<input type="checkbox"/> Reserved	136
26	<input type="checkbox"/> Temporary Raised Pavement Markers	137
27	<input type="checkbox"/> Restoring Bridge Approach Pavements Using High-Density Foam	138
28	<input type="checkbox"/> Portland Cement Concrete Inlay or Overlay	141
29	<input type="checkbox"/> Portland Cement Concrete Partial Depth Hot-Mix Asphalt Patching	145
30	<input type="checkbox"/> Longitudinal Joint and Crack Patching	148
31	<input type="checkbox"/> Concrete Mix Design - Department Provided	150
32	<input type="checkbox"/> Station Numbers in Pavements or Overlays	151



Local Public Agency

County

Section Number

Morton Road District

Tazewell

24-14000-03-GM(N-MFT)

The Following Local Roads And Streets Recurring Special Provisions Indicated By An "X" Are Applicable To This Contract And Are Included By Reference:

Local Roads And Streets Recurring Special Provisions

<u>Check Sheet #</u>		<u>Page No.</u>
LRS 1	<b>Reserved</b>	153
LRS 2	<input type="checkbox"/> Furnished Excavation	154
LRS 3	<input checked="" type="checkbox"/> Work Zone Traffic Control Surveillance	155
LRS 4	<input checked="" type="checkbox"/> Flaggers in Work Zones	156
LRS 5	<input checked="" type="checkbox"/> Contract Claims	157
LRS 6	<input checked="" type="checkbox"/> Bidding Requirements and Conditions for Contract Proposals	158
LRS 7	<input type="checkbox"/> Bidding Requirements and Conditions for Material Proposals	164
LRS 8	<b>Reserved</b>	170
LRS 9	<input type="checkbox"/> Bituminous Surface Treatments	171
LRS 10	<b>Reserved</b>	175
LRS 11	<input checked="" type="checkbox"/> Employment Practices	176
LRS 12	<input checked="" type="checkbox"/> Wages of Employees on Public Works	178
LRS 13	<input checked="" type="checkbox"/> Selection of Labor	180
LRS 14	<input type="checkbox"/> Paving Brick and Concrete Paver Pavements and Sidewalks	181
LRS 15	<input checked="" type="checkbox"/> Partial Payments	184
LRS 16	<input type="checkbox"/> Protests on Local Lettings	185
LRS 17	<input checked="" type="checkbox"/> Substance Abuse Prevention Program	186
LRS 18	<input type="checkbox"/> Multigrade Cold Mix Asphalt	187
LRS 19	<input type="checkbox"/> Reflective Crack Control Treatment	188

## TABLE OF CONTENTS

Page 1	Bidding Requirements and Conditions Description of Work Traffic Traffic Control Plan
Page 2	Hot-Mix Asphalt Binder and Surface Course Substitution of Bituminous Mixtures Hot-Mix Asphalt Surface Removal- Butt Joint Incidental Hot-Mix Asphalt Surfacing Weight Limits General Notes Pre-Construction Meeting Time Schedule
Page 3-4	Wages of Employees on Public Works BDE Special Provisions Check Sheets
Page 5-17	BDE Special Provisions
Page 18-25	LR Special Provisions
Page 26	Project Location Map
Page 27	Quantity Sheet
Page 28	Typical Cross Section
Page 29	Standard for HMA Surfacing at Sideroads, Entrances & Mailboxes
Page 30-32	Butt Joints
Page 33-41	Traffic Control Standards



Local Public Agency	County	Section Number
Morton Road District	Tazewell	24-14000-03-GM(N-MFT)

The following Special Provision supplement the "Standard Specifications for Road and Bridge Construction", adopted

January 1, 2022, the latest edition of the "Manual on Uniform Traffic Control Devices for Streets and Highways", and the "Manual of Test Procedures of Materials" in effect on the date of invitation of bids, and the Supplemental Specification and Recurring Special Provisions indicated on the Check Sheet included here in which apply to and govern the construction of the above named section, and in case of conflict with any parts, or parts of said Specifications, the said Special Provisions shall take precedence and shall govern.

**BIDDING REQUIREMENTS AND CONDITIONS:** Prequalification of bidders with the Illinois Department of Transportation is required.

**DESCRIPTION OF WORK:** The work of this section consists of Hot-Mix Asphalt Surface Removal- Butt Joint, Hot-Mix Asphalt Binder Course, N50, Hot-Mix Asphalt Surface Course, IL-9.5, Mix "C", N50 over an existing bituminous surface and related work.

**TRAFFIC:** TR 71-A Broadway Road shall be closed to through traffic during the following operations: Hot-Mix Asphalt Surface Removal - Butt Joint, Polymerized Bituminous Materials (Tack Coat), Hot-Mix Asphalt Binder Course, N50 and Hot-Mix Asphalt Surface Course, IL-9.5, Mix "C", N50. The Morton Township Highway Commissioner shall be notified a minimum 48 hours in advance of the start of construction to properly notify the property owners along the construction improvement route.

**TRAFFIC CONTROL PLAN:** Traffic Control shall be in accordance with the applicable sections of the "Standard Specifications for Road and Bridge Construction", the applicable guidelines contained in the "Manual on Uniform Traffic Control Devices for Streets and Highways", these Special Provisions, and any special details and Highway Standards contained herein and in the plans.

Special attention is called to Articles 107.09 and 107.14 of the "Standard Specifications for Road and Bridge Construction" and the Traffic Control Standards 701006-05, 701011-04, 701201-05, 701301-04, 701306-04, 701901-09 and BLR 21-9 contained herein.

The presence of temporary traffic control drawings or standards in the proposal or contract, whether a pay item or not, does not relieve the Contractor of his obligation to the public. The Contractor shall provide, if conditions warrant by the Engineer, all protection deemed necessary beyond that shown in the proposal or Special Provisions.

"NO PASSING ZONES NOT STRIPED NEXT \_\_\_\_ MILES" signs shall be posted in accordance with Article 701.17.

Construction signs shall meet the current Standard Specifications for Traffic Control Items.

Basis of payment: All required Traffic Control shall be paid for at the contract-lump sum price for TRAFFIC CONTROL & PROTECTION, (SPECIAL).

**HOT-MIX ASPHALT BINDER AND SURFACE COURSE:** This work shall be constructed in accordance with Article 406 of the "Standard Specifications for Road and Bridge Construction" except that the minimum lift thickness shall be 1 inch for HOT-MIX ASPHALT BINDER COURSE IL 9.5, N50 and 1.50 inch for HOT-MIX ASPHALT SURFACE COURSE IL 9.5, "C" N50 as specified on the typical cross section elsewhere herein.

Morton Road District

Tazewell

24-14000-03-GM(N-MFT)

**SUBSTITUTION OF BITUMINOUS MIXTURES:** Bituminous Mixtures of a higher quality may be substituted for the designs specified at the approval of the Engineer. The contractor shall provide the Engineer with an approved mix design at least 24 hours prior to its use for his review. Use of the proposed substitute mix shall be solely at the discretion of the Engineer. The new mixture will be measured and paid for under the same applicable articles as the mixture for which it is substituted.

**HOT-MIX ASPHALT SURFACE REMOVAL- BUTT JOINT:**

The surface removal shall be performed according to Article 406.08 and Section 440.

Revise Article 440.06 Disposal of Material to read as follows: All milled material shall remain the property of the Morton Township Road District and shall be transported from the job site to the Morton Township Road District storage yard located at 27833 Cooper Road in Morton, Illinois behind Roanoke Farmers Association-Cooper Station grain elevator facility. Other sites may be determined by mutual agreement between the Contractor and the Road District. If other sites are approved, the Contractor will be responsible for preventing theft of milled material or unauthorized removal of said material from sites other than Morton Township Road District property.

Add the following to Article 440.08 Basis of Payment: Hauling of milled material shall be included in the cost of HOT-MIX ASPHALT SURFACE REMOVAL - BUTT JOINT and no extra compensation will be allowed.

**INCIDENTAL HOT-MIX ASPHALT SURFACING:** Any preparation required prior to construction of INCIDENTAL HOT-MIX ASPHALT SURFACING will not be measured separately but shall be included in the contract unit price per ton for INCIDENTAL HOT-MIX ASPHALT SURFACING. To prevent damage to newly constructed bituminous surfaces, it is understood that an interval of up to one week shall lapse before incidental hot-mix asphalt surfacing operations begin, depending on weather and curing conditions, as directed by the Engineer.

**AGGREGATE SHOULDERS:** Aggregate shoulders shall be constructed by others.

**WEIGHT LIMITS:** Legal weight limits shall be observed on Morton Road District roads and structures they contain at all times.

**GENERAL NOTES:** Where section or subsection monuments are encountered, the Engineer shall be notified before such monuments are removed. The Contractor shall protect and carefully preserve all property markers and monuments until the owner, and authorized surveyor or agent has witnessed or otherwise referenced their location.

**PRE-CONSTRUCTION MEETING:** A pre-construction meeting for this Section is required between the Contractor, Highway Commissioner and the Resident Engineer.

**TIME SCHEDULE:** The specified completion date for this project is September 1, 2024.

**WAGES OF EMPLOYEES ON PUBLIC WORKS:** Add the following to paragraph #1 of the Special Provision for Wages of Employees on Public Works, Check Sheet LRS#12: Prevailing wage rates may be obtained from the IDOL (Illinois Department of Labor) website at:

<https://www2.illinois.gov/idol/Laws-Rules/CONMED/Pages/Rates.asp>

BDE SPECIAL PROVISIONS  
For the April 26 and June 14, 2024 Lettings

The following special provisions indicated by a “check mark” are applicable to this contract and will be included by the Project Coordination and Implementation Section of the Bureau of Design & Environment (BDE).

File Name	#		Special Provision Title	Effective	Revised	
	80099	1	<input type="checkbox"/>	Accessible Pedestrian Signals (APS)	April 1, 2003	Jan. 1, 2022
	80274	2	<input type="checkbox"/>	Aggregate Subgrade Improvement	April 1, 2012	April 1, 2022
	80192	3	<input type="checkbox"/>	Automated Flagger Assistance Devices	Jan. 1, 2008	April 1, 2023
	80173	4	<input type="checkbox"/>	Bituminous Materials Cost Adjustments	Nov. 2, 2006	Aug. 1, 2017
	80426	5	<input type="checkbox"/>	Bituminous Surface Treatment with Fog Seal	Jan. 1, 2020	Jan. 1, 2022
*	80241	6	<input type="checkbox"/>	Bridge Demolition Debris	July 1, 2009	
*	50531	7	<input type="checkbox"/>	Building Removal	Sept. 1, 1990	Aug. 1, 2022
*	50261	8	<input type="checkbox"/>	Building Removal with Asbestos Abatement	Sept. 1, 1990	Aug. 1, 2022
	80449	9	<input type="checkbox"/>	Cement, Type IL	Aug. 1, 2023	
	80384	10	<input checked="" type="checkbox"/>	Compensable Delay Costs	June 2, 2017	April 1, 2019
*	80198	11	<input type="checkbox"/>	Completion Date (via calendar days)	April 1, 2008	
*	80199	12	<input type="checkbox"/>	Completion Date (via calendar days) Plus Working Days	April 1, 2008	
	80453	13	<input type="checkbox"/>	Concrete Sealer	Nov. 1, 2023	
	80261	14	<input type="checkbox"/>	Construction Air Quality – Diesel Retrofit	June 1, 2010	Nov. 1, 2014
	80434	15	<input type="checkbox"/>	Corrugated Plastic Pipe (Culvert and Storm Sewer)	Jan. 1, 2021	
*	80029	16	<input type="checkbox"/>	Disadvantaged Business Enterprise Participation	Sept. 1, 2000	Mar. 2, 2019
	80229	17	<input type="checkbox"/>	Fuel Cost Adjustment	April 1, 2009	Aug. 1, 2017
	80452	18	<input type="checkbox"/>	Full Lane Sealant Waterproofing System	Nov. 1, 2023	
	80447	19	<input type="checkbox"/>	Grading and Shaping Ditches	Jan. 1, 2023	
	80433	20	<input type="checkbox"/>	Green Preformed Thermoplastic Pavement Markings	Jan. 1, 2021	Jan. 1, 2022
	80443	21	<input type="checkbox"/>	High Tension Cable Median Barrier Removal	April 1, 2022	
	80456	22	<input checked="" type="checkbox"/>	Hot-Mix Asphalt	Jan. 1, 2024	
	80446	23	<input type="checkbox"/>	Hot-Mix Asphalt - Longitudinal Joint Sealant	Nov. 1, 2022	Aug. 1, 2023
	80438	24	<input type="checkbox"/>	Illinois Works Apprenticeship Initiative – State Funded Contracts	June 2, 2021	April 2, 2024
	80045	25	<input type="checkbox"/>	Material Transfer Device	June 15, 1999	Jan. 1, 2022
	80450	26	<input type="checkbox"/>	Mechanically Stabilized Earth Retaining Walls	Aug. 1, 2023	
	80441	27	<input checked="" type="checkbox"/>	Performance Graded Asphalt Binder	Jan. 1, 2023	
	80451	28	<input type="checkbox"/>	Portland Cement Concrete	Aug. 1, 2023	
*	34261	29	<input type="checkbox"/>	Railroad Protective Liability Insurance	Dec. 1, 1986	Jan. 1, 2022
	80455	30	<input checked="" type="checkbox"/>	Removal and Disposal of Regulated Substances	Jan. 1, 2024	April 1, 2024
	80445	31	<input type="checkbox"/>	Seeding	Nov. 1, 2022	
	80457	32	<input type="checkbox"/>	Short Term and Temporary Pavement Markings	April 1, 2024	
	80448	33	<input type="checkbox"/>	Source of Supply and Quality Requirements	Jan. 2, 2023	
	80340	34	<input type="checkbox"/>	Speed Display Trailer	April 2, 2014	Jan. 1, 2022
	80127	35	<input type="checkbox"/>	Steel Cost Adjustment	April 2, 2004	Jan. 1, 2022
	80397	36	<input type="checkbox"/>	Subcontractor and DBE Payment Reporting	April 2, 2018	
	80391	37	<input type="checkbox"/>	Subcontractor Mobilization Payments	Nov. 2, 2017	April 1, 2019
	80437	38	<input type="checkbox"/>	Submission of Payroll Records	April 1, 2021	Nov. 2, 2023
	80435	39	<input type="checkbox"/>	Surface Testing of Pavements – IRI	Jan. 1, 2021	Jan. 1, 2023
	80410	40	<input type="checkbox"/>	Traffic Spotters	Jan. 1, 2019	
*	20338	41	<input type="checkbox"/>	Training Special Provisions	Oct. 15, 1975	Sept. 2, 2021
	80429	42	<input type="checkbox"/>	Ultra-Thin Bonded Wearing Course	April 1, 2020	Jan. 1, 2022
	80439	43	<input checked="" type="checkbox"/>	Vehicle and Equipment Warning Lights	Nov. 1, 2021	Nov. 1, 2022
	80302	44	<input type="checkbox"/>	Weekly DBE Trucking Reports	June 2, 2012	Nov. 1, 2021
	80454	45	<input type="checkbox"/>	Wood Sign Support	Nov. 1, 2023	
	80427	46	<input type="checkbox"/>	Work Zone Traffic Control Devices	Mar. 2, 2020	
*	80071	47	<input type="checkbox"/>	Working Days	Jan. 1, 2002	

Highlighted items indicate a new or revised special provision for the letting.

An \* indicates the special provision requires additional information from the designer, which needs to be submitted separately. The Project Coordination and Implementation Section will then include the information in the applicable special provision.

The following special provisions are in the 2024 Supplemental Specifications and Recurring Special Provisions.

<u>File Name</u>	<u>Special Provision Title</u>	<u>New Location(s)</u>	<u>Effective</u>	<u>Revised</u>
80436	Blended Finely Divided Minerals	Articles 1010.01 & 1010.06	April 1, 2021	
80440	Waterproofing Membrane System	Article 1061.05	Nov. 1, 2021	

## COMPENSABLE DELAY COSTS (BDE)

Effective: June 2, 2017

Revised: April 1, 2019

Revise Article 107.40(b) of the Standard Specifications to read:

“(b) Compensation. Compensation will not be allowed for delays, inconveniences, or damages sustained by the Contractor from conflicts with facilities not meeting the above definition; or if a conflict with a utility in an unanticipated location does not cause a shutdown of the work or a documentable reduction in the rate of progress exceeding the limits set herein. The provisions of Article 104.03 notwithstanding, compensation for delays caused by a utility in an unanticipated location will be paid according to the provisions of this Article governing minor and major delays or reduced rate of production which are defined as follows.

- (1) Minor Delay. A minor delay occurs when the work in conflict with the utility in an unanticipated location is completely stopped for more than two hours, but not to exceed two weeks.
- (2) Major Delay. A major delay occurs when the work in conflict with the utility in an unanticipated location is completely stopped for more than two weeks.
- (3) Reduced Rate of Production Delay. A reduced rate of production delay occurs when the rate of production on the work in conflict with the utility in an unanticipated location decreases by more than 25 percent and lasts longer than seven calendar days.”

Revise Article 107.40(c) of the Standard Specifications to read:

“(c) Payment. Payment for Minor, Major, and Reduced Rate of Production Delays will be made as follows.

- (1) Minor Delay. Labor idled which cannot be used on other work will be paid for according to Article 109.04(b)(1) and (2) for the time between start of the delay and the minimum remaining hours in the work shift required by the prevailing practice in the area.

Equipment idled which cannot be used on other work, and which is authorized to standby on the project site by the Engineer, will be paid for according to Article 109.04(b)(4).

- (2) Major Delay. Labor will be the same as for a minor delay.

Equipment will be the same as for a minor delay, except Contractor-owned equipment will be limited to two weeks plus the cost of move-out to either the

Contractor's yard or another job and the cost to re-mobilize, whichever is less. Rental equipment may be paid for longer than two weeks provided the Contractor presents adequate support to the Department (including lease agreement) to show retaining equipment on the job is the most economical course to follow and in the public interest.

- (3) Reduced Rate of Production Delay. The Contractor will be compensated for the reduced productivity for labor and equipment time in excess of the 25 percent threshold for that portion of the delay in excess of seven calendar days. Determination of compensation will be in accordance with Article 104.02, except labor and material additives will not be permitted.

Payment for escalated material costs, escalated labor costs, extended project overhead, and extended traffic control will be determined according to Article 109.13."

Revise Article 108.04(b) of the Standard Specifications to read:

"(b) No working day will be charged under the following conditions.

- (1) When adverse weather prevents work on the controlling item.
- (2) When job conditions due to recent weather prevent work on the controlling item.
- (3) When conduct or lack of conduct by the Department or its consultants, representatives, officers, agents, or employees; delay by the Department in making the site available; or delay in furnishing any items required to be furnished to the Contractor by the Department prevents work on the controlling item.
- (4) When delays caused by utility or railroad adjustments prevent work on the controlling item.
- (5) When strikes, lock-outs, extraordinary delays in transportation, or inability to procure critical materials prevent work on the controlling item, as long as these delays are not due to any fault of the Contractor.
- (6) When any condition over which the Contractor has no control prevents work on the controlling item."

Revise Article 109.09(f) of the Standard Specifications to read:

"(f) Basis of Payment. After resolution of a claim in favor of the Contractor, any adjustment in time required for the work will be made according to Section 108. Any adjustment in the costs to be paid will be made for direct labor, direct materials, direct equipment, direct jobsite overhead, direct offsite overhead, and other direct costs allowed by the resolution. Adjustments in costs will not be made for interest charges, loss of anticipated profit, undocumented loss of efficiency, home office overhead and unabsorbed overhead



other than as allowed by Article 109.13, lost opportunity, preparation of claim expenses and other consequential indirect costs regardless of method of calculation.

The above Basis of Payment is an essential element of the contract and the claim cost recovery of the Contractor shall be so limited.”

Add the following to Section 109 of the Standard Specifications.

**“109.13 Payment for Contract Delay.** Compensation for escalated material costs, escalated labor costs, extended project overhead, and extended traffic control will be allowed when such costs result from a delay meeting the criteria in the following table.

Contract Type	Cause of Delay	Length of Delay
Working Days	Article 108.04(b)(3) or Article 108.04(b)(4)	No working days have been charged for two consecutive weeks.
Completion Date	Article 108.08(b)(1) or Article 108.08(b)(7)	The Contractor has been granted a minimum two week extension of contract time, according to Article 108.08.

Payment for each of the various costs will be according to the following.

- (a) Escalated Material and/or Labor Costs. When the delay causes work, which would have otherwise been completed, to be done after material and/or labor costs have increased, such increases will be paid. Payment for escalated material costs will be limited to the increased costs substantiated by documentation furnished by the Contractor. Payment for escalated labor costs will be limited to those items in Article 109.04(b)(1) and (2), except the 35 percent and 10 percent additives will not be permitted.
- (b) Extended Project Overhead. For the duration of the delay, payment for extended project overhead will be paid as follows.
  - (1) Direct Jobsite and Offsite Overhead. Payment for documented direct jobsite overhead and documented direct offsite overhead, including onsite supervisory and administrative personnel, will be allowed according to the following table.

Original Contract Amount	Supervisory and Administrative Personnel
Up to \$5,000,000	One Project Superintendent
Over \$ 5,000,000 - up to \$25,000,000	One Project Manager, One Project Superintendent or Engineer, and One Clerk
Over \$25,000,000 - up to \$50,000,000	One Project Manager, One Project Superintendent, One Engineer, and

	One Clerk
Over \$50,000,000	One Project Manager, Two Project Superintendents, One Engineer, and One Clerk

(2) Home Office and Unabsorbed Overhead. Payment for home office and unabsorbed overhead will be calculated as 8 percent of the total delay cost.

(c) Extended Traffic Control. Traffic control required for an extended period of time due to the delay will be paid for according to Article 109.04.

When an extended traffic control adjustment is paid under this provision, an adjusted unit price as provided for in Article 701.20(a) for increase or decrease in the value of work by more than ten percent will not be paid.

Upon payment for a contract delay under this provision, the Contractor shall assign subrogation rights to the Department for the Department's efforts of recovery from any other party for monies paid by the Department as a result of any claim under this provision. The Contractor shall fully cooperate with the Department in its efforts to recover from another party any money paid to the Contractor for delay damages under this provision."

80384

## **HOT-MIX ASPHALT (BDE)**

Effective: January 1, 2024

Revise the second paragraph of Articles 1030.07(a)(11) and 1030.08(a)(9) of the Standard Specifications to read:

“When establishing the target density, the HMA maximum theoretical specific gravity ( $G_{mm}$ ) will be based on the running average of four available Department test results for that project. If less than four  $G_{mm}$  test results are available, an average of all available Department test results for that project will be used. The initial  $G_{mm}$  will be the last available Department test result from a QMP project. If there is no available Department test result from a QMP project, the Department mix design verification test result will be used as the initial  $G_{mm}$ .”

In the Supplemental Specifications, replace the revision for the end of the third paragraph of Article 1030.09(h)(2) with the following:

“When establishing the target density, the HMA maximum theoretical specific gravity ( $G_{mm}$ ) will be the Department mix design verification test result.”

Revise the tenth paragraph of Article 1030.10 of the Standard Specifications to read:

“Production is not required to stop after a test strip has been constructed.”

80456

## PERFORMANCE GRADED ASPHALT BINDER (BDE)

Effective: January 1, 2023

Revise Article 1032.05 of the Standard Specifications to read:

**“1032.05 Performance Graded Asphalt Binder.** These materials will be accepted according to the Bureau of Materials Policy Memorandum, “Performance Graded Asphalt Binder Qualification Procedure.” The Department will maintain a qualified producer list. These materials shall be free from water and shall not foam when heated to any temperature below the actual flash point. Air blown asphalt, recycle engine oil bottoms (ReOB), and polyphosphoric acid (PPA) modification shall not be used.

When requested, producers shall provide the Engineer with viscosity/temperature relationships for the performance graded asphalt binders delivered and incorporated in the work.

- (a) Performance Graded (PG) Asphalt Binder. The asphalt binder shall meet the requirements of AASHTO M 320, Table 1 “Standard Specification for Performance Graded Asphalt Binder” for the grade shown on the plans and the following.

Test	Parameter
Small Strain Parameter (AASHTO PP 113) BBR, $\Delta T_c$ , 40 hrs PAV (40 hrs continuous or 2 PAV at 20 hrs)	-5 °C min.

- (b) Modified Performance Graded (PG) Asphalt Binder. The asphalt binder shall meet the requirements of AASHTO M 320, Table 1 “Standard Specification for Performance Graded Asphalt Binder” for the grade shown on the plans.

Asphalt binder modification shall be performed at the source, as defined in the Bureau of Materials Policy Memorandum, “Performance Graded Asphalt Binder Qualification Procedure.”

Modified asphalt binder shall be safe to handle at asphalt binder production and storage temperatures or HMA construction temperatures. Safety Data Sheets (SDS) shall be provided for all asphalt modifiers.

- (1) Polymer Modification (SB/SBS or SBR). Elastomers shall be added to the base asphalt binder to achieve the specified performance grade and shall be either a styrene-butadiene diblock, triblock copolymer without oil extension, or a styrene-butadiene rubber. The polymer modified asphalt binder shall be smooth, homogeneous, and be according to the requirements shown in Table 1 or 2 for the grade shown on the plans.

Table 1 - Requirements for Styrene-Butadiene Copolymer (SB/SBS) Modified Asphalt Binders		
Test	Asphalt Grade SB/SBS PG 64-28 SB/SBS PG 70-22	Asphalt Grade SB/SBS PG 64-34 SB/SBS PG 70-28 SB/SBS PG 76-22 SB/SBS PG 76-28
Separation of Polymer ITP, "Separation of Polymer from Asphalt Binder" Difference in °F (°C) of the softening point between top and bottom portions	4 (2) max.	4 (2) max.
TESTS ON RESIDUE FROM ROLLING THIN FILM OVEN TEST (AASHTO T 240)		
Elastic Recovery ASTM D 6084, Procedure A, 77 °F (25 °C), 100 mm elongation, %	60 min.	70 min.

Table 2 - Requirements for Styrene-Butadiene Rubber (SBR) Modified Asphalt Binders		
Test	Asphalt Grade SBR PG 64-28 SBR PG 70-22	Asphalt Grade SB/SBS PG 64-34 SB/SBS PG 70-28 SBR PG 76-22 SBR PG 76-28
Separation of Polymer ITP, "Separation of Polymer from Asphalt Binder" Difference in °F (°C) of the softening point between top and bottom portions	4 (2) max.	4 (2) max.
Toughness ASTM D 5801, 77 °F (25 °C), 20 in./min. (500 mm/min.), in.-lbs (N-m)	110 (12.5) min.	110 (12.5) min.
Tenacity ASTM D 5801, 77 °F (25 °C), 20 in./min. (500 mm/min.), in.-lbs (N-m)	75 (8.5) min.	75 (8.5) min.
TESTS ON RESIDUE FROM ROLLING THIN FILM OVEN TEST (AASHTO T 240)		
Elastic Recovery ASTM D 6084, Procedure A, 77 °F (25 °C), 100 mm elongation, %	40 min.	50 min.

- (2) Ground Tire Rubber (GTR) Modification. GTR modification is the addition of recycled ground tire rubber to liquid asphalt binder to achieve the specified performance grade. GTR shall be produced from processing automobile and/or truck tires by the ambient

grinding method or micronizing through a cryogenic process. GTR shall not exceed 1/16 in. (2 mm) in any dimension and shall not contain free metal particles, moisture that would cause foaming of the asphalt, or other foreign materials. A mineral powder (such as talc) meeting the requirements of AASHTO M 17 may be added, up to a maximum of four percent by weight of GTR to reduce sticking and caking of the GTR particles. When tested in accordance with Illinois Modified AASHTO T 27 “Standard Method of Test for Sieve Analysis of Fine and Coarse Aggregates” or AASHTO PP 74 “Standard Practice for Determination of Size and Shape of Glass Beads Used in Traffic Markings by Means of Computerized Optical Method”, a 50 g sample of the GTR shall conform to the following gradation requirements.

Sieve Size	Percent Passing
No. 16 (1.18 mm)	100
No. 30 (600 µm)	95 ± 5
No. 50 (300 µm)	> 20

GTR modified asphalt binder shall be tested for rotational viscosity according to AASHTO T 316 using spindle S27. GTR modified asphalt binder shall be tested for original dynamic shear and RTFO dynamic shear according to AASHTO T 315 using a gap of 2 mm.

The GTR modified asphalt binder shall meet the requirements of Table 3.

Table 3 - Requirements for Ground Tire Rubber (GTR) Modified Asphalt Binders		
Test	Asphalt Grade GTR PG 64-28 GTR PG 70-22	Asphalt Grade GTR PG 76-22 GTR PG 76-28 GTR PG 70-28
TESTS ON RESIDUE FROM ROLLING THIN FILM OVEN TEST (AASHTO T 240)		
Elastic Recovery ASTM D 6084, Procedure A, 77 °F (25 °C), 100 mm elongation, %	60 min.	70 min.

- (3) Softener Modification (SM). Softener modification is the addition of organic compounds, such as engineered flux, bio-oil blends, modified vegetable oils, glycol amines, and fatty acid derivatives, to the base asphalt binder to achieve the specified performance grade. Softeners shall be dissolved, dispersed, or reacted in the asphalt binder to enhance its performance and shall remain compatible with the asphalt binder with no separation. Softeners shall not be added to modified PG asphalt binder as defined in Articles 1032.05(b)(1) or 1032.05(b)(2).

An Attenuated Total Reflectance-Fourier Transform Infrared spectrum (ATR-FTIR) shall be collected for both the softening compound as well as the softener modified

asphalt binder at the dose intended for qualification. The ATR-FTIR spectra shall be collected on unaged softener modified binder, 20-hour Pressurized Aging Vessel (PAV) aged softener modified binder, and 40-hour PAV aged softener modified binder. The ATR-FTIR shall be collected in accordance with Illinois Test Procedure 601. The electronic files spectral files (in one of the following extensions or equivalent: \*.SPA, \*.SPG, \*.IRD, \*.IFG, \*.CSV, \*.SP, \*.IRS, \*.GAML, \*. [0-9], \*.IGM, \*.ABS, \*.DRT, \*.SBM, \*.RAS) shall be submitted to the Central Bureau of Materials.

Softener modified asphalt binders shall meet the requirements in Table 4.

Test	Asphalt Grade	
	SM PG 46-28	SM PG 46-34
	SM PG 52-28	SM PG 52-34
	SM PG 58-22	SM PG 58-28
	SM PG 64-22	
Small Strain Parameter (AASHTO PP 113) BBR, $\Delta T_c$ , 40 hrs PAV (40 hrs continuous or 2 PAV at 20 hrs)	-5°C min.	
Large Strain Parameter (Illinois Modified AASHTO T 391) DSR/LAS Fatigue Property, $\Delta G^* _{peak}$ , 40 hrs PAV (40 hrs continuous or 2 PAV at 20 hrs)	≥ 54 %	

The following grades may be specified as tack coats.

Asphalt Grade	Use
PG 58-22, PG 58-28, PG 64-22	Tack Coat

Revise Article 1031.06(c)(1) and 1031.06(c)(2) of the Standard Specifications to read:

“(1) RAP/RAS. When RAP is used alone or RAP is used in conjunction with RAS, the percentage of virgin ABR shall not exceed the amounts listed in the following table.

Ndesign	Binder	Surface	Polymer Modified Binder or Surface <sup>3/</sup>
30	30	30	10
50	25	15	10
70	15	10	10
90	10	10	10

1/ For Low ESAL HMA shoulder and stabilized subbase, the RAP/RAS ABR shall not exceed 50 percent of the mixture.

- 2/ When RAP/RAS ABR exceeds 20 percent, the high and low virgin asphalt binder grades shall each be reduced by one grade (i.e. 25 percent ABR would require a virgin asphalt binder grade of PG 64-22 to be reduced to a PG 58-28).
  - 3/ The maximum ABR percentages for ground tire rubber (GTR) modified mixes shall be equivalent to the percentages specified for SBS/SBR polymer modified mixes.
- (2) FRAP/RAS. When FRAP is used alone or FRAP is used in conjunction with RAS, the percentage of virgin asphalt binder replacement shall not exceed the amounts listed in the following table.

HMA Mixtures - FRAP/RAS Maximum ABR % <sup>1/ 2/</sup>			
Ndesign	Binder	Surface	Polymer Modified Binder or Surface <sup>3/</sup>
30	55	45	15
50	45	40	15
70	45	35	15
90	45	35	15
SMA	--	--	25
IL-4.75	--	--	35

- 1/ For Low ESAL HMA shoulder and stabilized subbase, the FRAP/RAS ABR shall not exceed 50 percent of the mixture.
- 2/ When FRAP/RAS ABR exceeds 20 percent for all mixes, the high and low virgin asphalt binder grades shall each be reduced by one grade (i.e. 25 percent ABR would require a virgin asphalt binder grade of PG 64-22 to be reduced to a PG 58-28).
- 3/ The maximum ABR percentages for GTR modified mixes shall be equivalent to the percentages specified for SBS/SBR polymer modified mixes.”

Add the following to the end of Note 2 of Article 1030.03 of the Standard Specifications.

“A dedicated storage tank for the ground tire rubber (GTR) modified asphalt binder shall be provided. This tank shall be capable of providing continuous mechanical mixing throughout and/or recirculation of the asphalt binder to provide a uniform mixture. The tank shall be heated and capable of maintaining the temperature of the asphalt binder at 300 °F to 350 °F (149 °C to 177 °C). The asphalt binder metering systems of dryer drum plants shall be calibrated with the actual GTR modified asphalt binder material with an accuracy of ±0.40 percent.”



## REMOVAL AND DISPOSAL OF REGULATED SUBSTANCES (BDE)

Effective: January 1, 2024

Revised: April 1, 2024

Revise the first paragraph of Article 669.04 of the Standard Specifications to read:

**“669.04 Regulated Substances Monitoring.** Regulated substances monitoring includes environmental observation and field screening during regulated substances management activities. The excavated soil and groundwater within the work areas shall be managed as either uncontaminated soil, hazardous waste, special waste, or non-special waste.

As part of the regulated substances monitoring, the monitoring personnel shall perform and document the applicable duties listed on form BDE 2732 “Regulated Substances Monitoring Daily Record (RSM DR)”.”

Revise the first two sentences of the nineteenth paragraph of Article 669.05 of the Standard Specifications to read:

“The Contractor shall coordinate waste disposal approvals with the disposal facility and provide the specific analytical testing requirements of that facility. The Contractor shall make all arrangements for collection, transportation, and analysis of landfill acceptance testing.”

Revise the last paragraph of Article 669.05 of the Standard Specifications to read:

“The Contractor shall select a permitted landfill facility or CCDD/USFO facility meeting the requirements of 35 Ill. Admin. Code Parts 810-814 or Part 1100, respectively. The Department will review and approve or reject the facility proposed by the Contractor based upon information provided in BDE 2730. The Contractor shall verify whether the selected facility is compliant with those applicable standards as mandated by their permit and whether the facility is presently, has previously been, or has never been, on the United States Environmental Protection Agency (U.S. EPA) National Priorities List or the Resource Conservation and Recovery Act (RCRA) List of Violating Facilities. The use of a Contractor selected facility shall in no manner delay the construction schedule or alter the Contractor's responsibilities as set forth.”

Revise the first paragraph of Article 669.07 of the Standard Specifications to read:

**“669.07 Temporary Staging.** Soil classified according to Articles 669.05(a)(2), (b)(1), or (c) may be temporarily staged at the Contractor's option. All other soil classified according to Articles 669.05(a)(1), (a)(3), (a)(4), (a)(5), (a)(6), or (b)(2) shall be managed and disposed of without temporary staging to the greatest extent practicable. If circumstances beyond the Contractor's control require temporary staging of these latter materials, the Contractor shall request approval from the Engineer in writing.

Topsoil for re-use as final cover which has been field screened and found not to exhibit PID readings over daily background readings as documented on the BDE 2732, visual staining or

odors, and is classified according to Articles 669.05(a)(2), (a)(3), (a)(4), (b)(1), or (c) may be temporarily staged at the Contractor's option."

Add the following paragraph after the sixth paragraph of Article 669.11 of the Standard Specifications.

"The sampling and testing of effluent water derived from dewatering discharges for priority pollutants volatile organic compounds (VOCs), priority pollutants semi-volatile organic compounds (SVOCs), or priority pollutants metals, will be paid for at the contract unit price per each for VOCS GROUNDWATER ANALYSIS using EPA Method 8260B, SVOCS GROUNDWATER ANALYSIS using EPA Method 8270C, or RCRA METALS GROUNDWATER ANALYSIS using EPA Methods 6010B and 7471A. This price shall include transporting the sample from the job site to the laboratory."

Revise the first sentence of the eight paragraph of Article 669.11 of the Standard Specifications to read:

"Payment for temporary staging of soil classified according to Articles 669.05(a)(1), (a)(3), (a)(4), (a)(5), (a)(6), or (b)(2) to be managed and disposed of, if required and approved by the Engineer, will be paid according to Article 109.04."

80455

## **VEHICLE AND EQUIPMENT WARNING LIGHTS (BDE)**

Effective: November 1, 2021

Revised: November 1, 2022

Add the following paragraph after the first paragraph of Article 701.08 of the Standard Specifications:

“The Contractor shall equip all vehicles and equipment with high-intensity oscillating, rotating, or flashing, amber or amber-and-white, warning lights which are visible from all directions. In accordance with 625 ILCS 5/12-215, the lights may only be in operation while the vehicle or equipment is engaged in construction operations.”

80439

State of Illinois  
Department of Transportation  
Bureau of Local Roads and Streets

SPECIAL PROVISION  
FOR  
INSURANCE

Effective: February 1, 2007  
Revised: August 1, 2007

All references to Sections or Articles in this specification shall be construed to mean specific Section or Article of the Standard Specifications for Road and Bridge Construction, adopted by the Department of Transportation.

The Contractor shall name the following entities as additional insured under the Contractor's general liability insurance policy in accordance with Article 107.27:

Morton Road District

---

Tazewell County

---

---

---

---

---

---

---

The entities listed above and their officers, employees, and agents shall be indemnified and held harmless in accordance with Article 107.26.

State of Illinois  
Department of Transportation  
Bureau of Local Roads and Streets

SPECIAL PROVISION  
FOR  
EQUIPMENT RENTAL RATES

Effective: January 1, 2012

All references to Sections or Articles in this specification shall be construed to mean a specific Section or Article of the Standard Specifications for Road and Bridge Construction, adopted by the Department of Transportation.

Replace Article 109.04(b)(4) with the following:

- "(4) Equipment. For any machinery or special equipment (other than small tools) the use of which has been authorized by the Engineer, the Contractor will be paid according to the latest revision of "SCHEDULE OF AVERAGE ANNUAL EQUIPMENT OWNERSHIP EXPENSE" and latest index factor as issued by the Illinois Department of Transportation. The equipment should be of a type and size reasonably required to complete the extra work."

State of Illinois  
Department of Transportation  
Bureau of Local Roads and Streets  
SPECIAL PROVISION  
FOR  
CONSTRUCTION AND MAINTENANCE SIGNS

Effective: January 1, 2004  
Revised: June 1, 2007

All references to Sections or Articles in this specification shall be construed to mean a specific Section or Article of the Standard Specifications for Road and Bridge Construction, adopted by the Department of Transportation.

701.14. Signs. Add the following paragraph to Article 701.14:

All warning signs shall have minimum dimensions of 1200 mm x 1200 mm (48" x 48") and have a black legend on a fluorescent orange reflectorized background, meeting, as a minimum, Type AP reflectivity requirements of Table 1091-2 in Article 1091.02.

State of Illinois  
 DEPARTMENT OF TRANSPORTATION  
 Bureau of Local Roads & Streets  
 SPECIAL PROVISION  
 FOR  
 LOCAL QUALITY ASSURANCE/ QUALITY MANAGEMENT QC/QA  
 Effective: January 1, 2022

Replace the first five paragraphs of Article 1030.06 of the Standard Specifications with the following:

**“1030.06 Quality Management Program.** The Quality Management Program (QMP) will be Quality Control / Quality Assurance (QC/QA) according to the following.”

Delete Article 1030.06(d)(1) of the Standard Specifications.

Revise Article 1030.09(g)(3) of the Standard Specifications to read:

“(3) If core testing is the density verification method, the Contractor shall provide personnel and equipment to collect density verification cores for the Engineer. Core locations will be determined by the Engineer following the document “Hot-Mix Asphalt QC/QA Procedure for Determining Random Density Locations” at density verification intervals defined in Article 1030.09(b). After the Engineer identifies a density verification location and prior to opening to traffic, the Contractor shall cut a 4 in. (100 mm) diameter core. With the approval of the Engineer, the cores may be cut at a later time.”

Revise Article 1030.09(h)(2) of the Standard Specifications to read:

“(2) After final rolling and prior to paving subsequent lifts, the Engineer will identify the random density verification test locations. Cores or nuclear density gauge testing will be used for density verification. The method used for density verification will be as selected below.

Density Verification Method	
<input type="checkbox"/>	Cores
<input checked="" type="checkbox"/>	Nuclear Density Gauge (Correlated when paving ≥ 3,000 tons per mixture)

Density verification test locations will be determined according to the document “Hot-Mix Asphalt QC/QA Procedure for Determining Random Density Locations”. The density testing interval for paving wider than or equal to 3 ft (1 m) will be 0.5 miles (800 m) for lift thicknesses of 3 in. (75 mm) or less and 0.2 miles (320 m) for lift thicknesses greater than 3 in. (75 mm). The density testing interval for paving less than 3 ft (1 m) wide will be 1 mile (1,600 m). If a day’s paving will be less than the prescribed density testing interval, the length of the day’s paving will be the interval for that day. The density testing interval for mixtures used for patching will be 50 patches with a minimum of one test per mixture per project.

If core testing is the density verification method, the Engineer will witness the Contractor coring, and secure and take possession of all density samples at the

density verification locations. The Engineer will test the cores collected by the Contractor for density according to Illinois Modified AASHTO T 166 or AASHTO T 275.

If nuclear density gauge testing is the density verification method, the Engineer will conduct nuclear density gauge tests. The Engineer will follow the density testing procedure detailed in the document "Illinois Modified ASTM D 2950, Standard Test Method for Density of Bituminous Concrete In-Place by Nuclear Method".

A density verification test will be the result of a single core or the average of the nuclear density tests at one location. The results of each density test must be within acceptable limits. The Engineer will promptly notify the Contractor of observed deficiencies."

Revise the seventh paragraph and all subsequent paragraphs in Section D. of the document "Hot-Mix Asphalt QC/QA Initial Daily Plant and Random Samples" to read:

"Mixtures shall be sampled from the truck at the plant by the Contractor following the same procedure used to collect QC mixture samples (Section A). This process will be witnessed by the Engineer who will take custody of the verification sample. Each sample bag with a verification mixture sample will be secured by the Engineer using a locking ID tag. Sample boxes containing the verification mixture sample will be sealed/taped by the Engineer using a security ID label."



State of Illinois  
DEPARTMENT OF TRANSPORTATION  
Bureau of Local Roads & Streets

SPECIAL PROVISION  
FOR  
EMULSIFIED ASPHALTS

Effective: January 1, 2007  
Revised: February 7, 2008

All references to Sections and Articles in this Special Provision shall be construed to mean specific Sections and Articles in the Standard Specifications for Road and Bridge Construction adopted by the Department of Transportation.

Replace the table after Note 2 in Article 403.02 with the following:

Type of Construction	Bituminous Materials Recommended for Weather Conditions Indicated	
	Warm [15 °C to 30 °C]* [(60 °F to 85 °F)]*	Hot [30 °C Plus]* [(85 °F Plus)]*
Prime	MC-30, PEP	MC-30, PEP
Cover Coat and Seal Coat	RS-2, CRS-2, RC-800, RC-3000, MC-800, MC-3000, SC-3000, HFE-90, HFE-150, HFE-300, HFRS-2, PEA**	RS-2, CRS-2, RC-800, RC-3000, MC-800, MC-3000, SC-3000, PG46-28, PG52-28, HFE-90, HFE-150, HFE-300, HFRS-2, PEA**

\* Temperature of the air in the shade at the time of application.

\*\* PEA is only allowed on roads with low traffic volumes

Replace the table after Note 2 in Article 406.02 with the following:

Type of Construction	Bituminous Materials Recommended
Prime (tack) on Brick, Concrete, or Bituminous Bases (Note 3)	SS-1, SS-1h, CSS-1, CSS-1h, HFE-90, RC-70
Prime on Aggregate Bases (Note 4)	MC-30, PEP
Mixture for Cracks, Joints, and Flangeways	PG58-22, PG64-22

Note 3. When emulsified asphalts are used, they shall be diluted with an equal volume of potable water. HFE emulsions shall be diluted by the manufacturer. The diluted material shall be thoroughly agitated within 24 hours of application and show no separation of water and emulsion. The diluted material shall not be returned to an approved emulsion storage tank.

Note 4. Preparation of the bituminous PEP shall be as specified in Article 403.05.

Replace the table in Article 1032.04 with the following:

Spraying Application Temperature Ranges		
Type and Grade of Bituminous Material	Temperature Ranges	
	°F min. - max.	°C min. - max.
PEP	60 - 130	15 - 55
PEA	140 - 190	60 - 88
MC-30	85 - 190	30 - 90
MC-70, RC-70, SC-70	120 - 225	50 - 105
MC-250, SC-250	165 - 270	75 - 130
MC-800, SC-800	200 - 305	95 - 150
MC-3000, SC-3000	230 - 345	110 - 175
PG46-28	275 - 385	135 - 195
PG52-28	285 - 395	140 - 200
RS-2, CRS-2	110 - 160	45 - 70
SS-1, SS-1h, CSS-1, CSS-1h	75 - 130	25 - 55
SS-1hP, CSS-1hP	75 - 130	25 - 55
HFE-90, HFE-150, HFE-300	150 - 180	65 - 80
HFP, CRSP, HFRS-2	150 - 180	65 - 80
E-2	85 - 190	30 - 90
E-3	120 - 225	50 - 105
E-4	165 - 270	75 - 130

Add subparagraph (g) to Article 1032.06:

- (g) Penetrating Emulsified Asphalt (PEA). The penetrating emulsified asphalt shall meet the following requirements when tested according to AASHTO T59:

Viscosity, Saybolt Fural @ 25°C (77°F),	sec:	20 - 500
Sieve Test, retained on 850 μm (No. 20) sieve, maximum,	%:	0.10
Storage Stability Test, 1 day, maximum,	%:	1
Float Test @ 60°C (140°F), minimum,	sec:	150
Stone Coating Test, 3 minutes,	:	Stone Coated Thoroughly
Particle Charge	:	Negative
pH, minimum	:	7.3
Distillation Test:		
Distillation to 260°C (500°F) Residue, minimum	%:	65
Oil Distillate by Volume, maximum	%:	3
Test on residue from distillation:		
Penetration @ 25°C (77°F), 100 g, 5 sec, minimum	dmm:	300

Replace the last sentence and table of Article 1032.06 with the following:

The different grades are, in general, used for the following.

Grade	Use
SS-1, SS-1h, CSS-1, CSS-1h, HFE 90, SS-1hP, CSS-1hP	Tack or fog seal
PEP	Bituminous surface treatment prime
RS-2, HFE 90, HFE 150, HFE 300, CRSP, HFP, CRS-2, HFRS-2, PEA	Bituminous surface treatment
CSS-1h Latex Modified	Microsurfacing

MORTON ROAD DISTRICT  
TWP. 25N, R 3W, 3rd P.M.  
24-14000-03-GM(N-MFT)

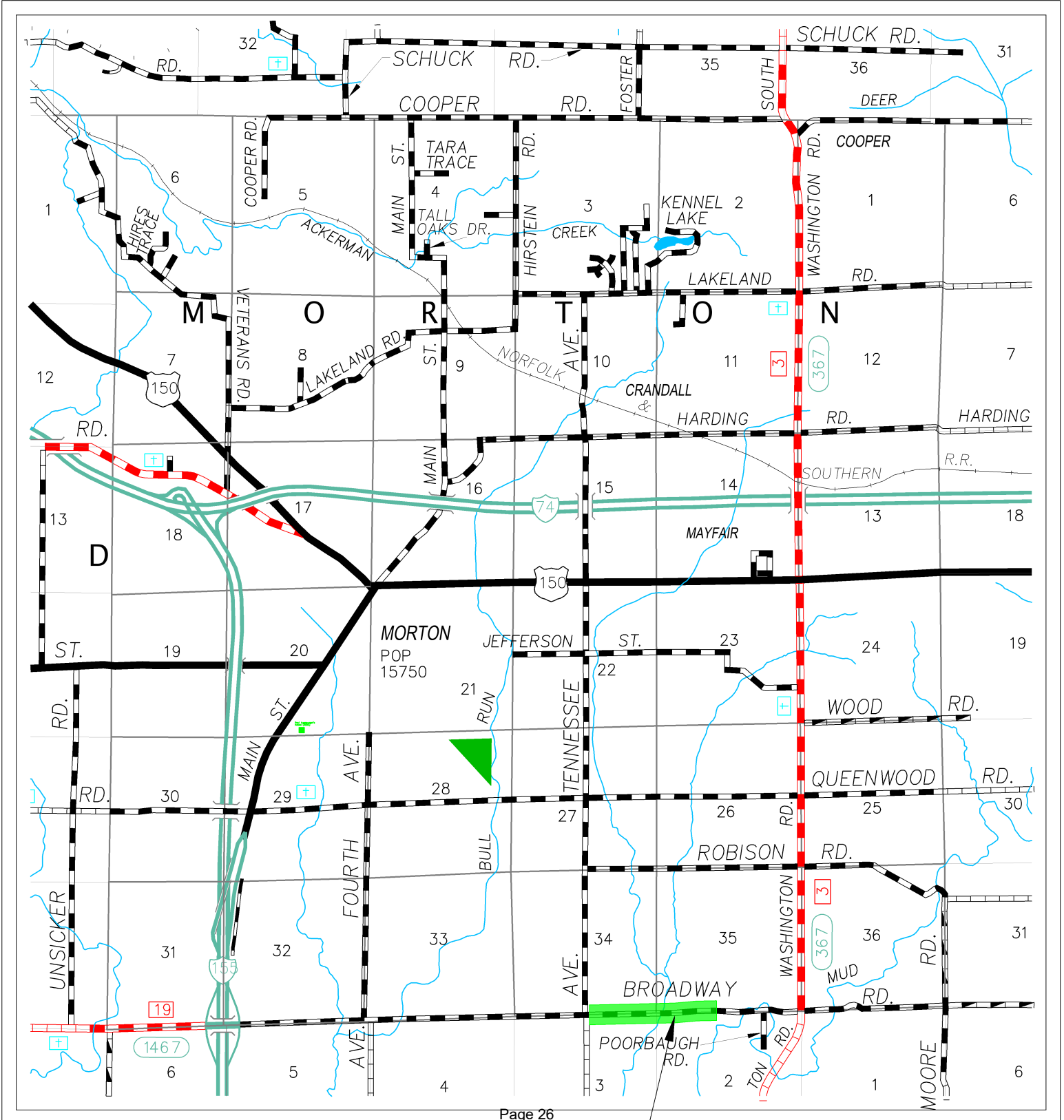

TR 71A / Broadway Rd

**QUANTITIES**

**Overlay**

<b><u>Route/Section</u></b>	<b><u>Length (ft)</u></b>	<b><u>Width (ft)</u></b>	<b><u>Area (SY)</u></b>
TR 71A / Broadway Rd	<u>3,700</u>	21	<u>8,932</u>

\*\*Includes Driveways & Mailboxes

<b><u>Hot-Mix Asphalt Surface Removal-Butt Joint:</u></b>	<b>330</b>	<b>SQ YD</b>
50' @ Each End		
433 LF Driveways @ 2'		

<b><u>Temporary Ramp:</u></b>	<b>18</b>	<b>SQ YD</b>
20'x4' Each End		

<b><u>Polymerized Bituminous Materials (Tack Coat):</u></b>	<b>12,862</b>	<b>POUND</b>
Rate = 0.72 lbs/SY on Existing Surface and between lifts		

<b><u>Hot-Mix Asphalt Binder Course, IL-9.5, N50:</u></b>	<b>493</b>	<b>TON</b>
8,805 SQ YD x 112# x 1 / 2000		

<b><u>Hot-Mix Asphalt Surface Course, IL-9.5, Mix "C", N50:</u></b>	<b>740</b>	<b>TON</b>
8,805 SQ YD x 112# x 1.5 / 2000		

<b><u>Incidental Hot-Mix Asphalt Surfacing:</u></b>	<b>18</b>	<b>TON</b>
127 SQ YD x 112# x 2.50" / 2000		

<b><u>Traffic Control and Protection, (Special):</u></b>	<b>1</b>	<b>L SUM</b>
----------------------------------------------------------	----------	--------------

# TYPICAL CROSS SECTION TR 71A / BROADWAY RD.

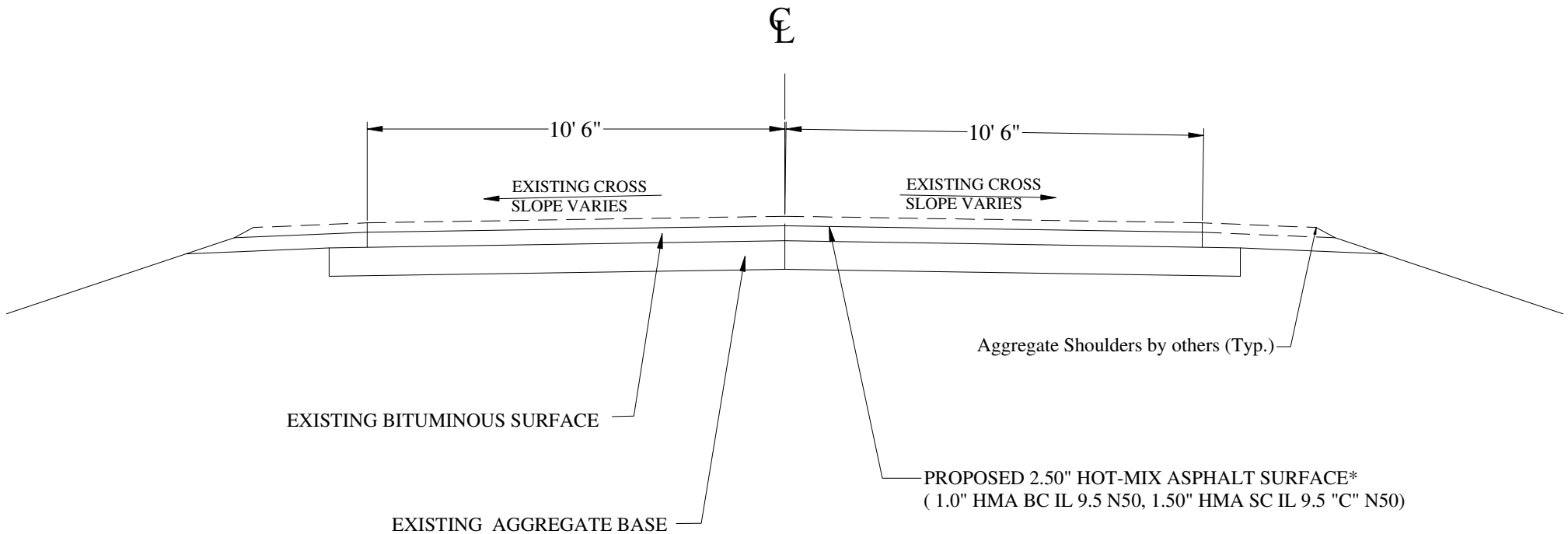

Location:	TR 71A / Broadway Rd	
Mixture Uses:	Binder Course	Surface Course
PG:	PG 58-28	PG 58-28
Design Air Voids:	4.0 @ N50	4.0 @ N50
Mixture Composition: (Gradation Mixture)	IL 9.5	IL 9.5
Friction Aggregate:	N/A	Mixture C

Section: 24-14000-03-GM(N-MFT)  
Route: TR 71A / Broadway Rd.  
Tennessee Rd Easterly to Township Limits

# STANDARD FOR HOT-MIX ASPHALT SURFACING AT SIDEROADS, ENTRANCES AND MAILBOXES

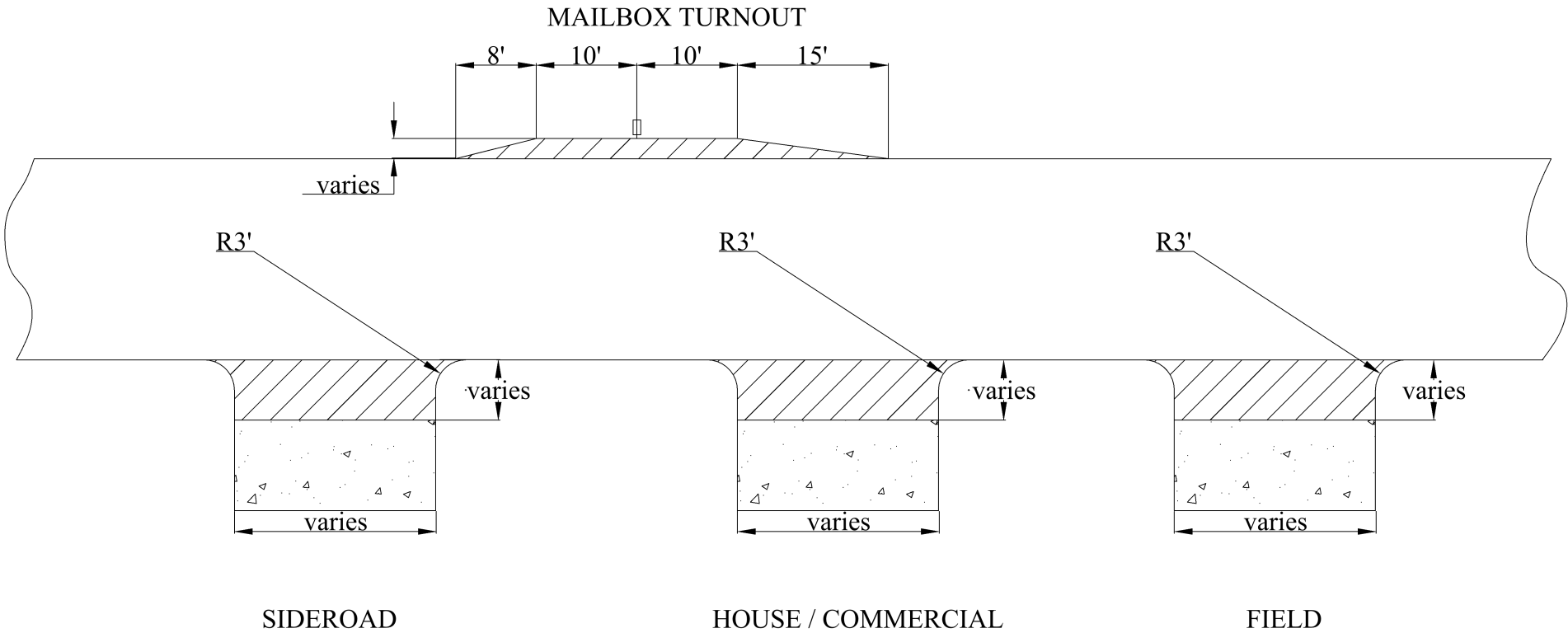

Notes: 1. Dimensions are approximate and may be adjusted in the field by the Engineer

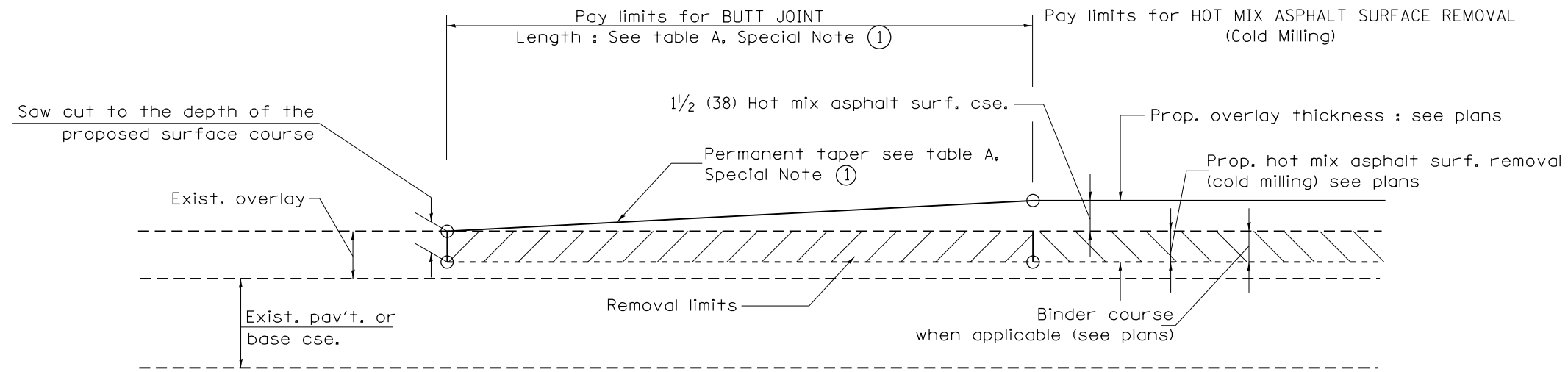

**CASE 1 : WITH HOT MIX ASPHALT SURFACE REMOVAL (COLD MILLING)**

**TABLE A  
TAPER RATES**

SPECIAL NOTE NUMBER	ELEMENT	MAINLINE INTERSTATES & 4-LANE EXPRESSWAYS	ALL OTHERS
①	BUTT JOINT TAPER RATE	1:480	1:240
②	TEMPORARY RAMP TAPER RATE	1:80	1:40

**GENERAL NOTES**

1. The work shall be done in accordance with Article 406.08 and the Special Provision for Butt Joints.
2. The pavement surface to be removed may be either bituminous or P.C. concrete. The work shall be performed in accordance with Article 440.04 and the Special Provisions for Butt Joints.
3. The saw cut joints shall be primed just prior to the placing of bituminous material. The work will be in accordance with the applicable portions of Article 406.05.
4. The length of butt joint is based on the taper rate times change in cold milling depth within the butt joint pay limits, unless otherwise indicated.
5. Temporary ramps are paid for separately and not included in the cost of the butt joints.

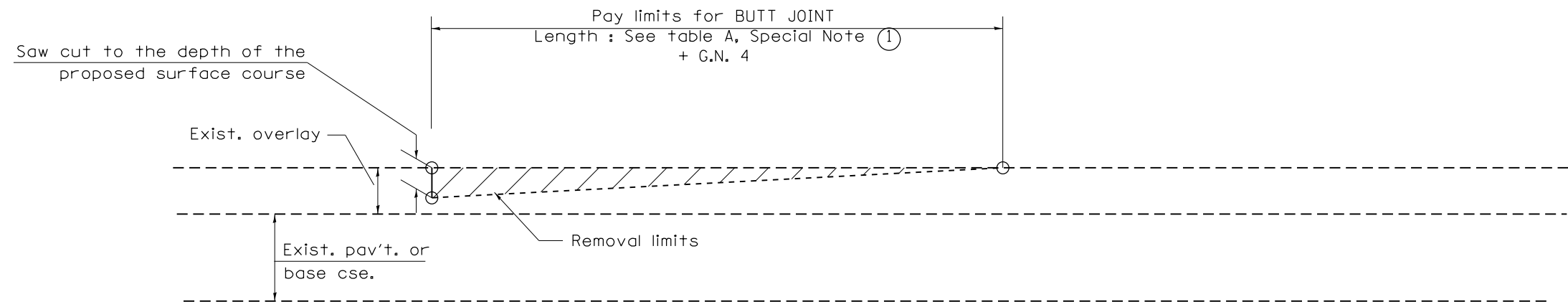

**CASE 2 : NO HOT MIX ASPHALT SURFACE REMOVAL (COLD MILLING)**

All dimensions are in inches (millimeters) unless otherwise noted.



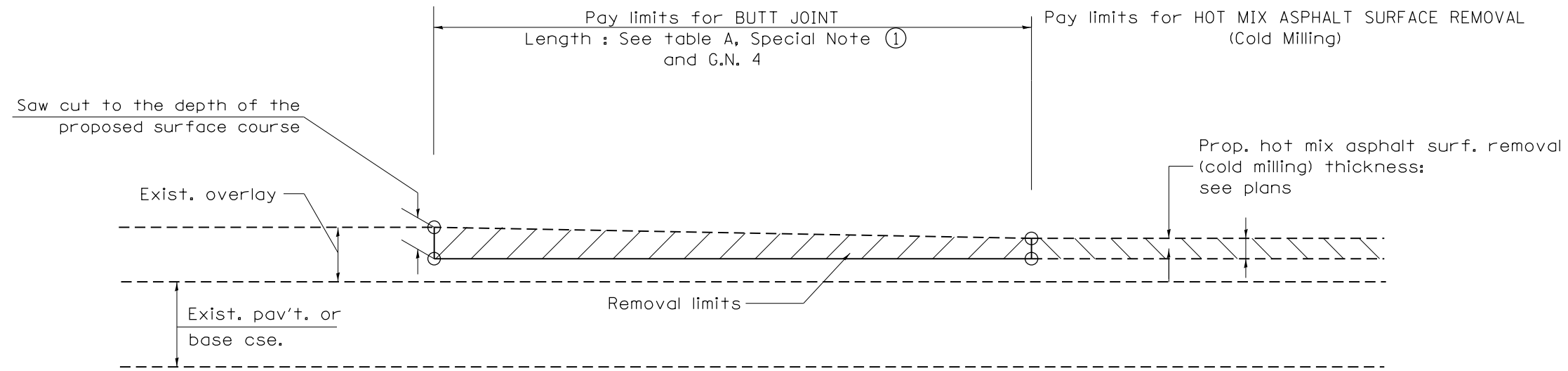

CASE 3 : HOT MIX ASPHALT SURFACE REMOVAL (COLD MILLING)  
TIE-IN TO EXISTING BITUMINOUS TAPER

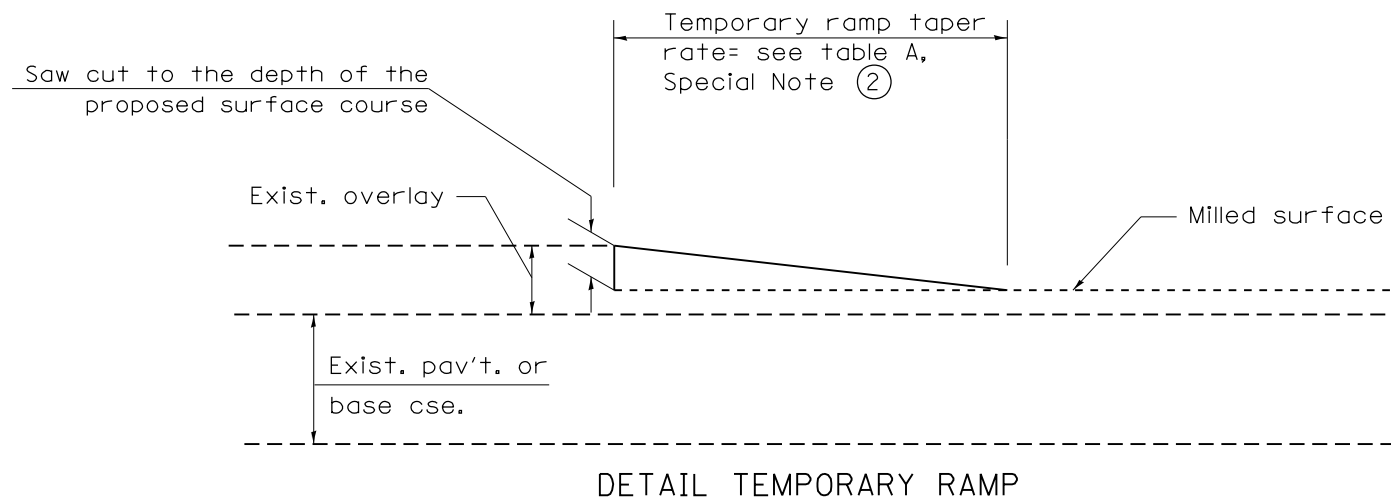

All dimensions are in inches (millimeters) unless otherwise noted.

				<b>STATE OF ILLINOIS DEPARTMENT OF TRANSPORTATION</b>		<b>BUTT JOINTS</b>		SHT. 2 OF 3 CADD STD. 406101-D4	
				Page 31		NOT TO SCALE		CONTRACT NO.	
F.A. RTE.	SECTION	COUNTY	TOTAL SHEETS	ILLINOIS FED. AID PROJECT					

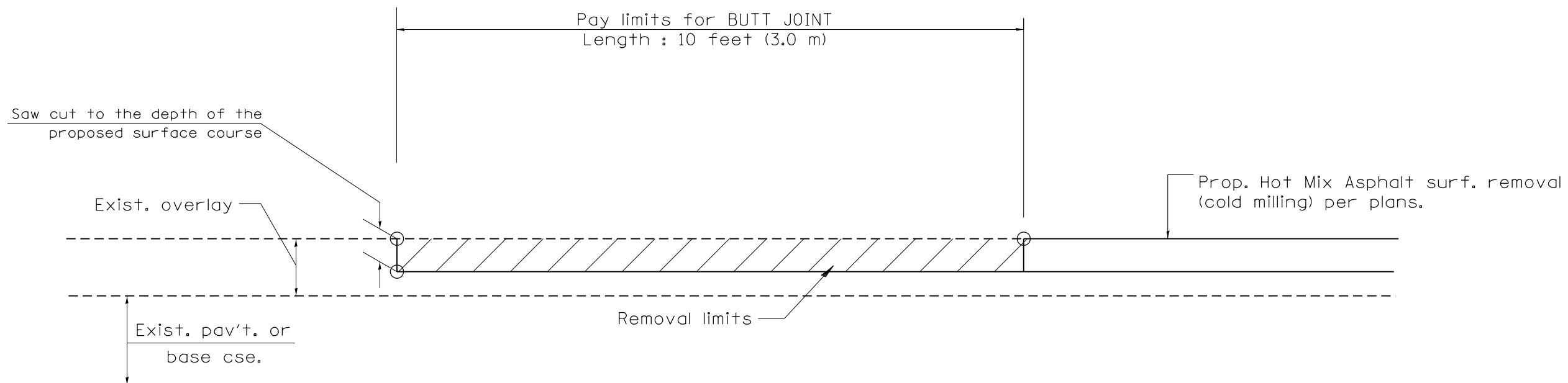

CASE 4 : SINGLE LIFT OVERLAY WITH EQUIVALENT DEPTH  
HOT MIX ASPHALT SURFACE REMOVAL (COLD MILLING)  
TIE-IN TO EXISTING BITUMINOUS TAPER

All dimensions are in inches (millimeters) unless otherwise noted.

						<b>STATE OF ILLINOIS</b> <b>DEPARTMENT OF TRANSPORTATION</b> Page 32	<b>BUTT JOINTS</b>	SHT. 3 OF 3 CADD STD. 406101-D4	CONTRACT NO.
									F.A. RTE. SECTION COUNTY TOTAL SHEETS SHEET NO.
									FED. ROAD DIST. NO. ILLINOIS FED. AID PROJECT

NOT TO SCALE

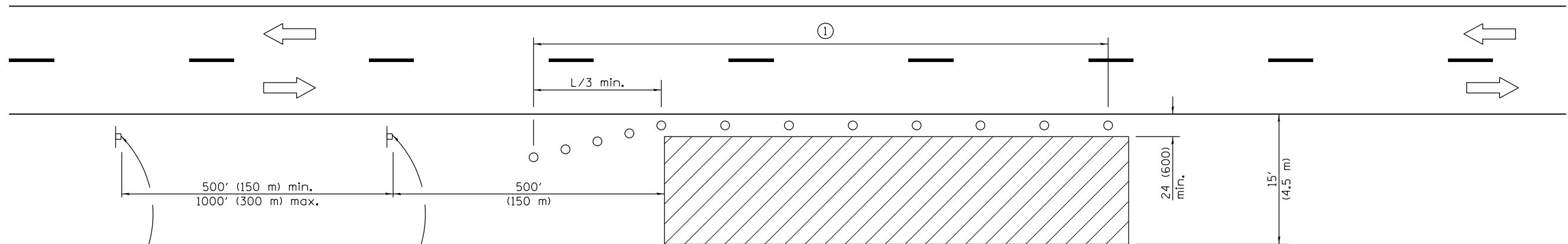

For contract construction projects

ROAD CONSTRUCTION AHEAD

W20-1103(0)-48



For maintenance and utility projects

ROAD WORK AHEAD

W20-1(0)-48

**TYPICAL APPLICATIONS**

- Utility operations
- Culvert extensions
- Side slope changes
- Guardrail installation and maintenance
- Delineator installation
- Landscaping operations
- Shoulder repair
- Sign installation and maintenance

**SYMBOLS**

- Work area
- Sign
- Cone, drum or barricade

① When the work operation exceeds one hour, cones, drums or barricades shall be placed at 25' (8 m) centers for L/3 distance, and at 50' (15 m) centers through the remainder of the work area.

**GENERAL NOTES**

This Standard is used where any vehicles, equipment, workers or their activities will encroach in the area 15' (4.5 m) to 24' (600 mm) from the edge of pavement.

Calculate L as follows:

SPEED LIMIT	FORMULAS	
	English	(Metric)
40 mph (70 km/h) or less:	$L = \frac{WS^2}{60}$	$L = \frac{WS^2}{150}$
45 mph (80 km/h) or greater:	$L = (W)(S)$	$L = 0.65(W)(S)$

W = Width of offset in feet (meters).

S = Normal posted speed mph (km/h).

All dimensions are in inches (millimeters) unless otherwise shown.

DATE	REVISIONS
1-1-14	Revised workers sign number to agree with current MUTCD.
1-1-13	Omitted text 'WORKERS' sign.

**OFF-RD OPERATIONS, 2L, 2W, 15' (4.5 m) TO 24" (600 mm) FROM PAVEMENT EDGE**

**STANDARD 701006-05**

Illinois Department of Transportation

APPROVED January 1, 2014  
  
 ENGINEER OF SAFETY ENGINEERING

APPROVED January 1, 2014  
  
 ENGINEER OF DESIGN AND ENVIRONMENT

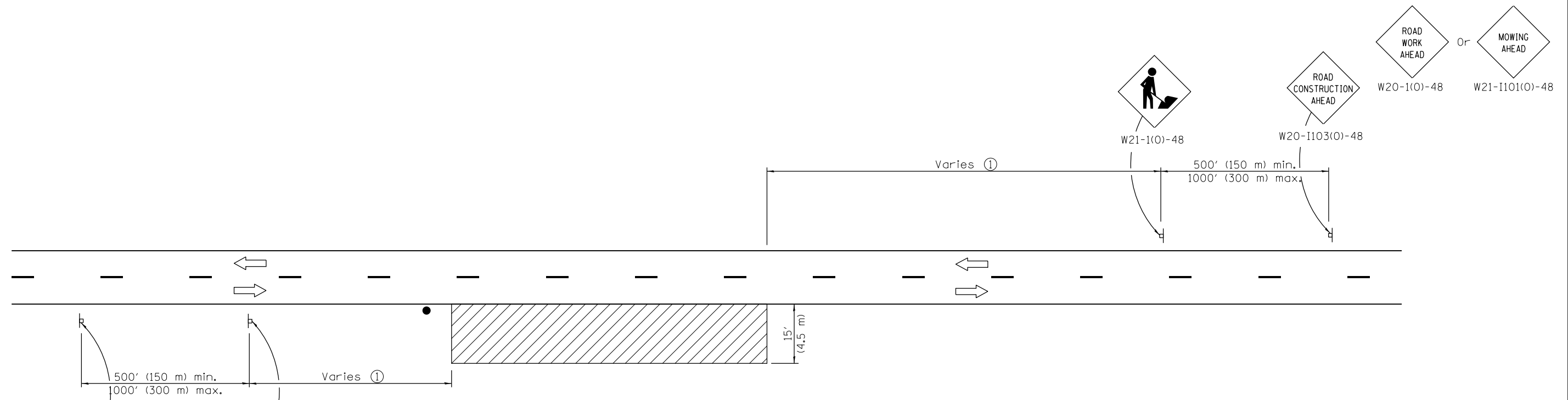

ISSUED 1-1-97

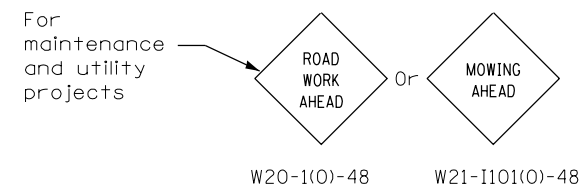
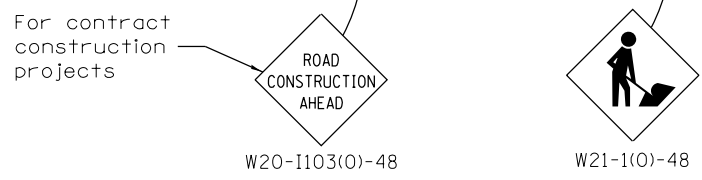

**TYPICAL APPLICATIONS**  
Shoulder work  
Utility operations

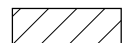

**SYMBOLS**

-  Work area
-  Sign
-  Flagger with traffic control sign when required

① Minimum distance is 200' (60 m). Maximum distance to be determined by the Engineer but should not exceed 1/2 the length required for one normal working day's operation, or 4 miles (6.4 km) whichever is less.

**GENERAL NOTES**

This Standard is used where at any time, any vehicle, equipment, workers or their activities require an intermittent or continuous moving operation on the shoulder, where the average speed is 1 mph (2 km/h) or less.

When the work operation does not exceed 60 minutes, traffic control may be according to Standard 701301.

All dimensions are in inches (millimeters) unless otherwise shown.

DATE	REVISIONS
1-1-14	Revised workers sign number to agree with current MUTCD.
1-1-13	Omitted text 'WORKERS' sign.

**OFF-RD MOVING OPERATIONS,  
2L, 2W, DAY ONLY**

---

**STANDARD 701011-04**

Illinois Department of Transportation

APPROVED January 1, 2014  
*[Signature]*  
ENGINEER OF SAFETY ENGINEERING

APPROVED January 1, 2014  
*[Signature]*  
ENGINEER OF DESIGN AND ENVIRONMENT

ISSUED 1-1-97

- ① Devices at 20' (6 m) centers in the taper.
- ② Cones at 25' (8 m) centers for the first 150' (45 m). Additional cones may be placed at 50' (15 m) centers. When drums or barricades are used, these intervals between devices may be doubled.

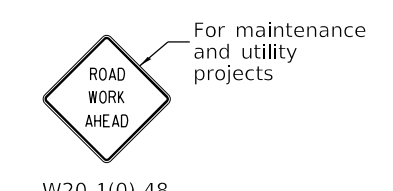
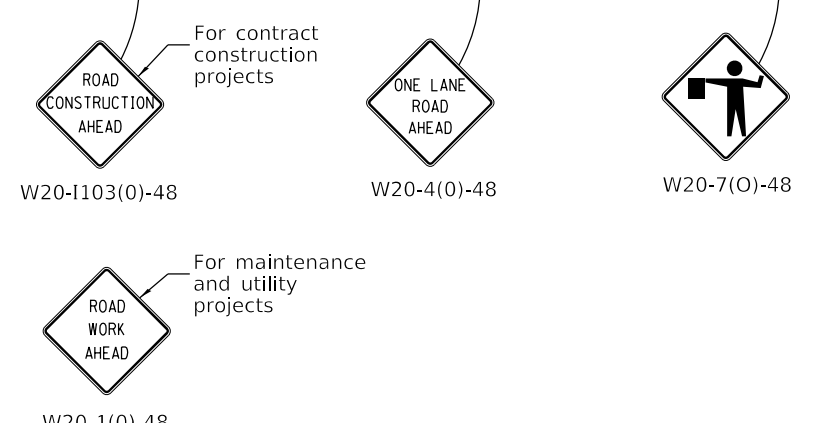
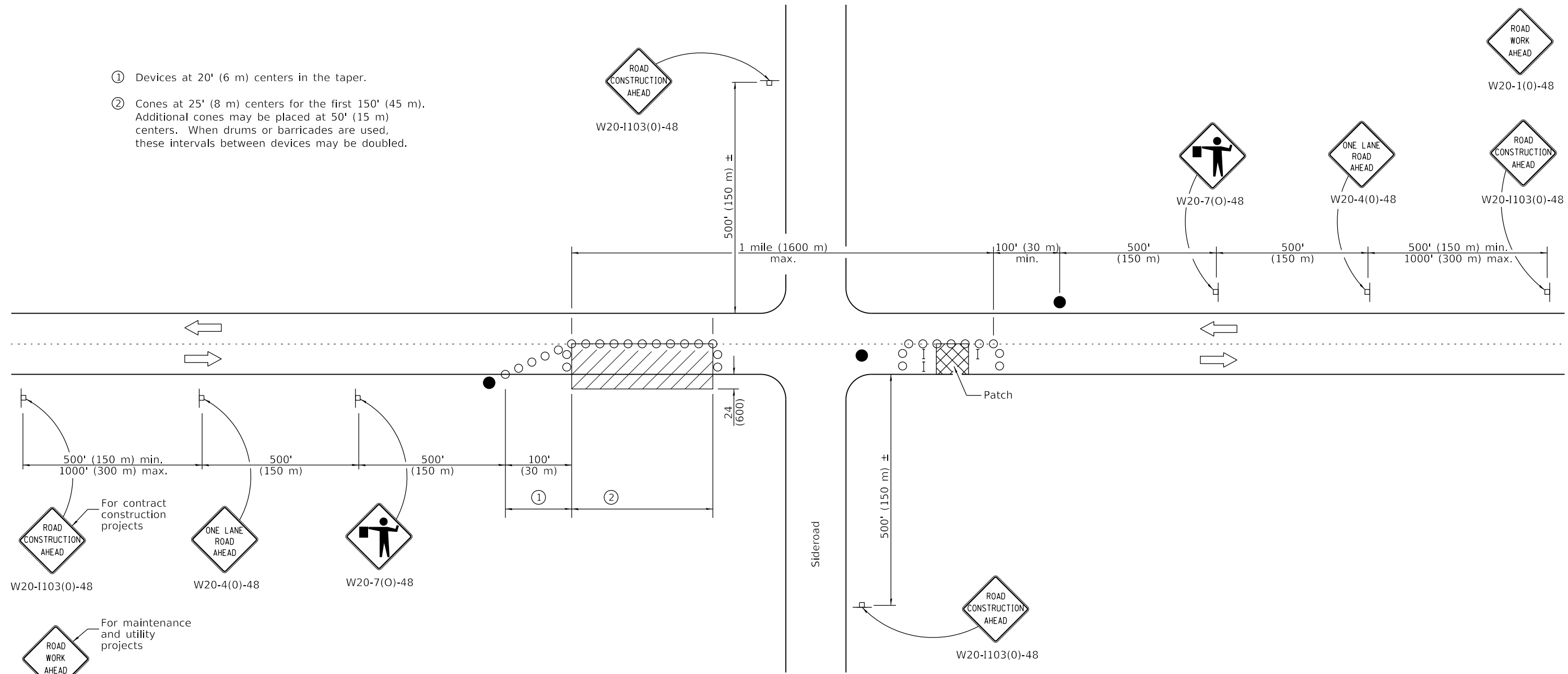

**TYPICAL APPLICATIONS**

- Isolated patching
- Utility operations
- Storm sewer
- Culverts
- Cable placement

**SYMBOLS**

- Work area
- Sign
- Barricade or drum
- Cone, drum or barricade
- Flagger with traffic control sign

**GENERAL NOTES**

This Standard is used where at any time, any vehicles, equipment, workers or their activities will encroach in the area between the center line and a line 24 (600) outside the edge of pavement for daylight operation.

When the distance between successive work areas exceeds 2000' (600 m), additional warning signs, flaggers, and taper shall be placed as shown.

All dimensions are in inches (millimeters) unless otherwise shown.

Illinois Department of Transportation

APPROVED January 1, 2019  
  
 ENGINEER OF SAFETY PROG. AND ENGINEERING

ISSUED 1-1-97

APPROVED January 1, 2019  
  
 ENGINEER OF DESIGN AND ENVIRONMENT

DATE	REVISIONS
1-1-19	Revised device spacing in taper.
1-1-11	Revised flagger sign.

**LANE CLOSURE, 2L, 2W,  
 DAY ONLY,  
 FOR SPEEDS ≥ 45 MPH**

**STANDARD 701201-05**

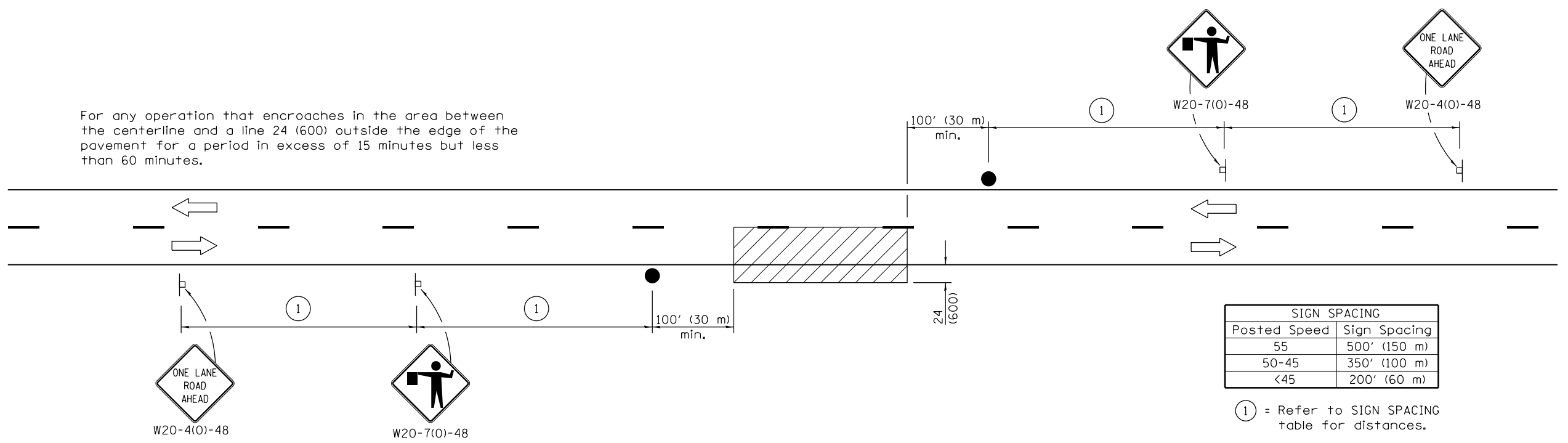
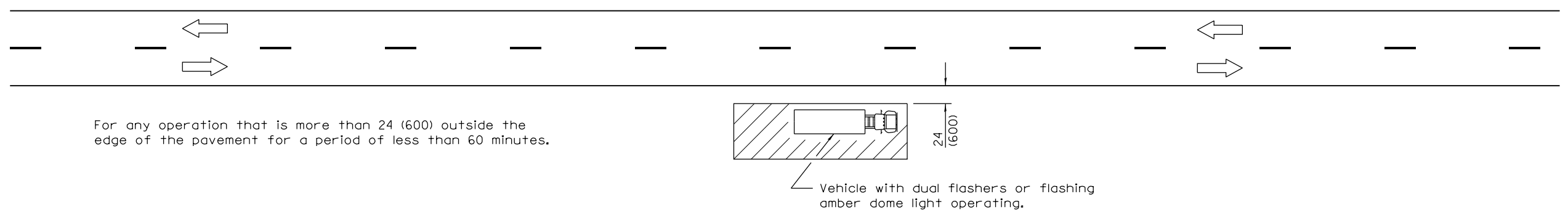
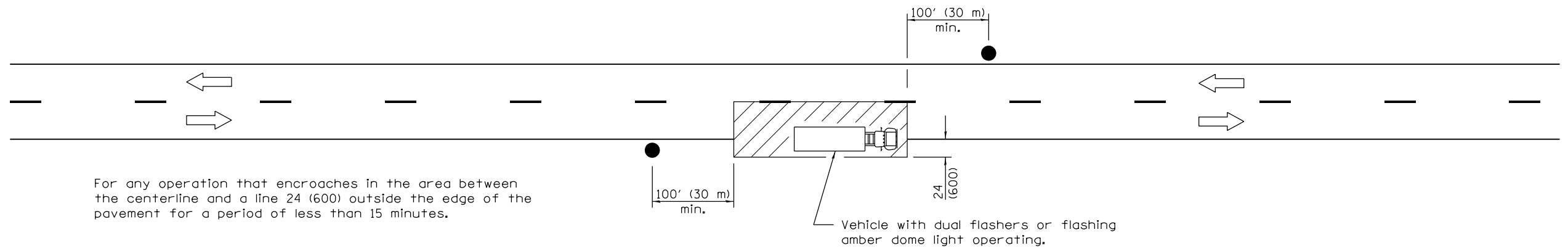

SIGN SPACING	
Posted Speed	Sign Spacing
55	500' (150 m)
50-45	350' (100 m)
<45	200' (60 m)

① = Refer to SIGN SPACING table for distances.

All dimensions are in inches (millimeters) unless otherwise shown.

**TYPICAL APPLICATIONS**

- Marking patches
- Field survey
- String line
- Utility operations
- Cleaning up debris on pavement

**SYMBOLS**

- Work area
- Sign on portable or permanent support
- Flagger with traffic control sign

DATE	REVISIONS
1-1-11	Revised flagger sign.
1-1-09	Switched units to English (metric).

**LANE CLOSURE, 2L, 2W, SHORT TIME OPERATIONS**

**STANDARD 701301-04**

Illinois Department of Transportation

APPROVED January 1, 2011  
*Amelia A. Davis*  
 ENGINEER OF SAFETY ENGINEERING

APPROVED January 1, 2011  
*Scott Schickel*  
 ENGINEER OF DESIGN AND ENVIRONMENT

ISSUED 1-1-97

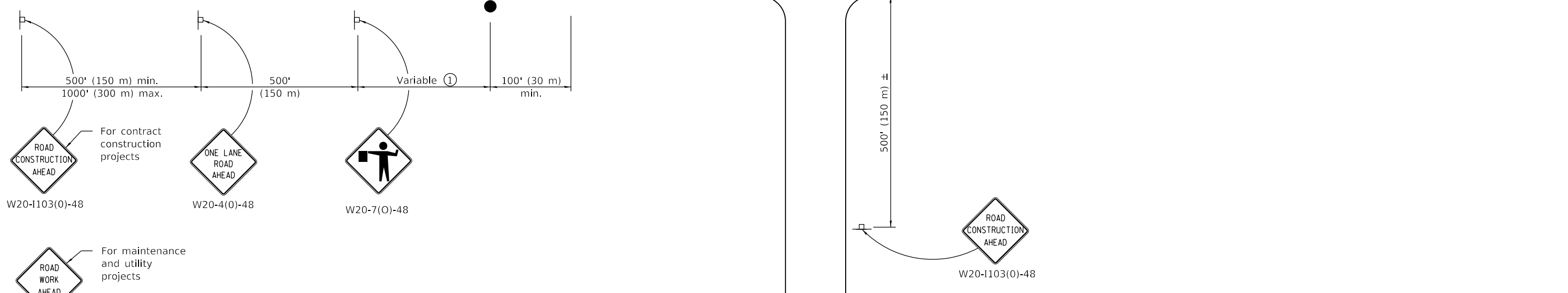
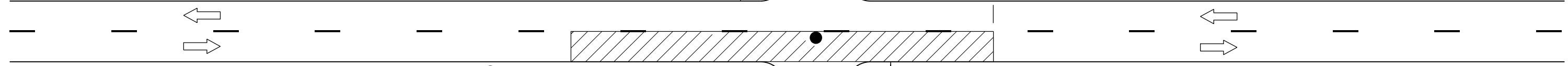
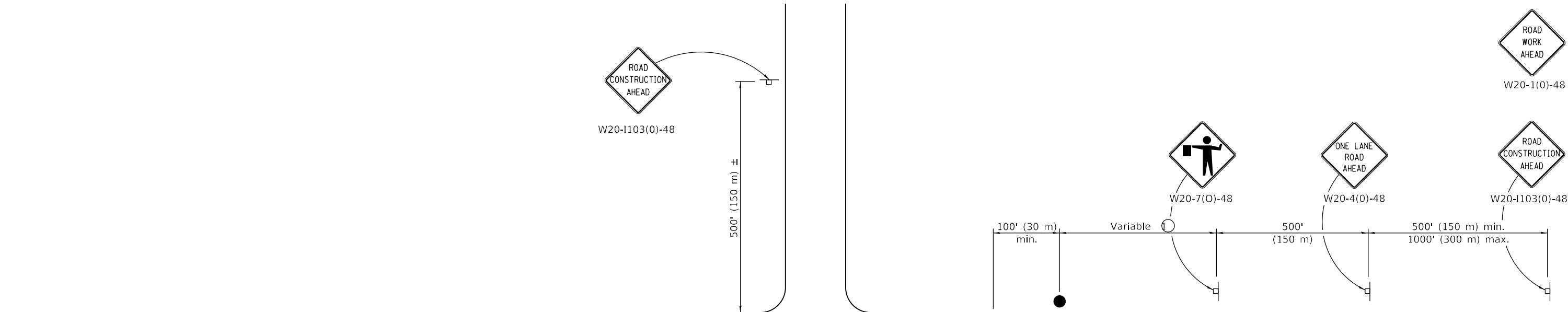

- For contract construction projects  
W20-1103(0)-48
- W20-4(0)-48
- W20-7(0)-48
- For maintenance and utility projects  
W20-1(0)-48

**TYPICAL APPLICATIONS**

- Bituminous resurfacing
- Milling operations
- Utility operations
- Shoulder operations

**SYMBOLS**

- Work area
- Sign on portable or permanent support
- Flagger with traffic control sign

① Minimum distance is 200' (60 m). Maximum distance to be determined by the Engineer but should not exceed ½ the length required for one normal working day's operation or 2 miles (3200 m), whichever is less.

**GENERAL NOTES**

This Standard is used where at any time, any vehicle, equipment, workers or their activities require an intermittent or continuous moving operation on the pavement where the average speed of movement is greater than ½ mph (1 km/h) and less than 4 mph (6 km/h).

When the operation does not exceed 60 minutes, traffic control may be according to Standard 701301.

All dimensions are in inches (millimeters) unless otherwise shown.

DATE	REVISIONS
1-1-18	Revised lower speed limit for operation to ½ mph.
1-1-11	Revised flagger sign.

**LANE CLOSURE, 2L, 2W, SLOW MOVING OPERATIONS DAY ONLY, FOR SPEEDS ≥ 45 MPH**

**STANDARD 701306-04**

Illinois Department of Transportation  
 PASSED January 1, 2018  
  
 ENGINEER OF SAFETY PROG. AND ENGINEERING  
 APPROVED January 1, 2018  
  
 ENGINEER OF DESIGN AND ENVIRONMENT

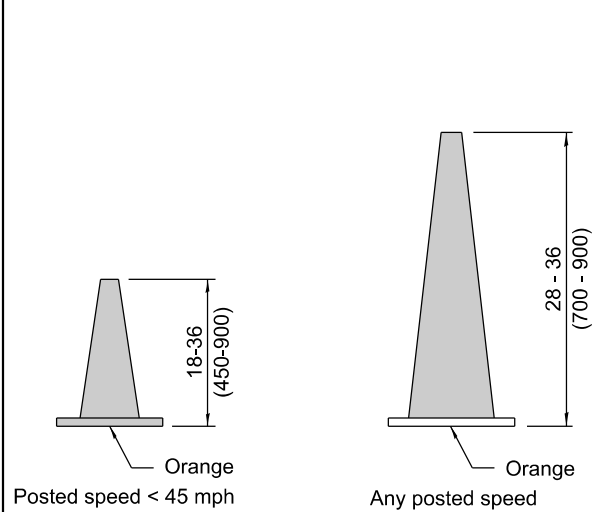

**DAYTIME USE**

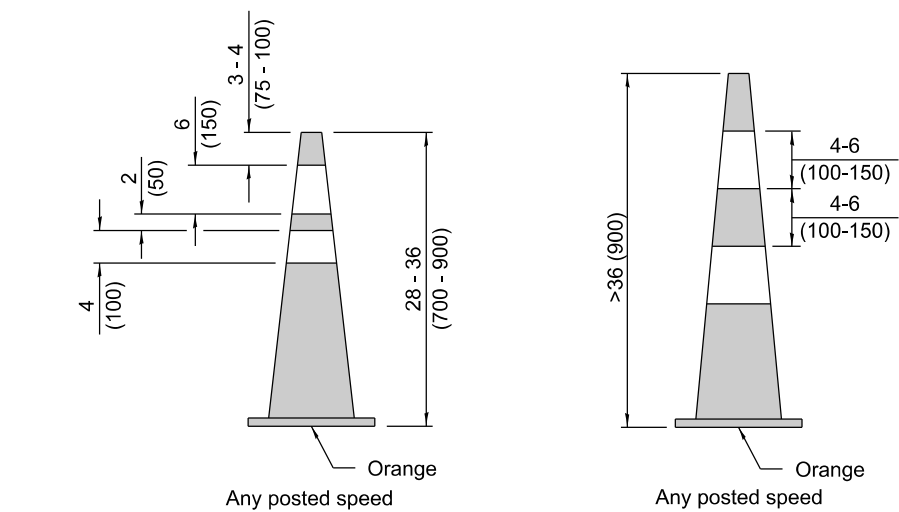

**DAY OR NIGHTTIME USE**

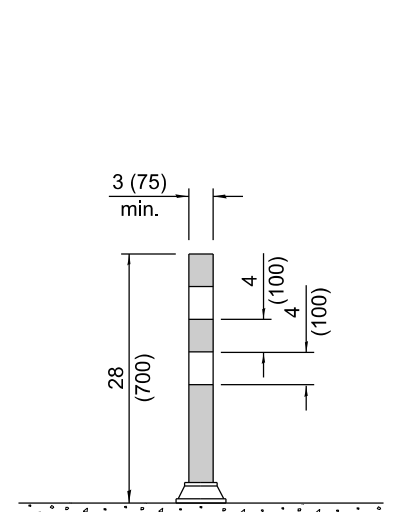

**TUBULAR MARKER**

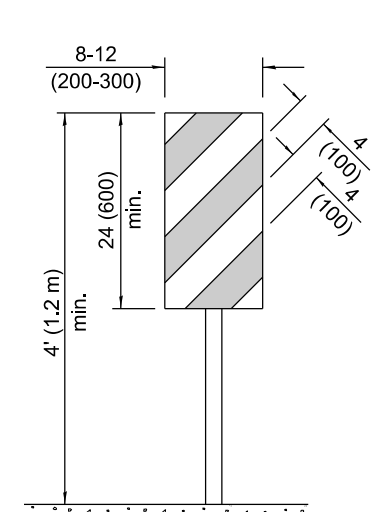

**VERTICAL PANEL POST MOUNTED**

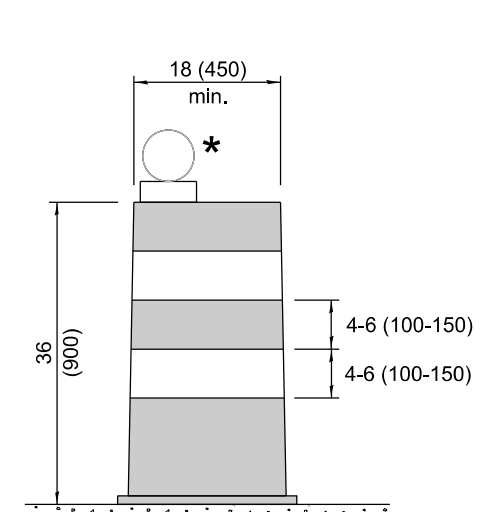

**DRUM**

**CONES**

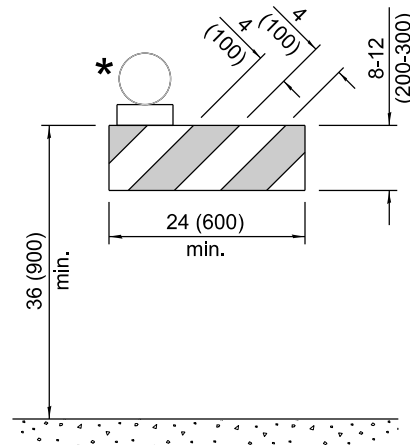

**TYPE I BARRICADE**

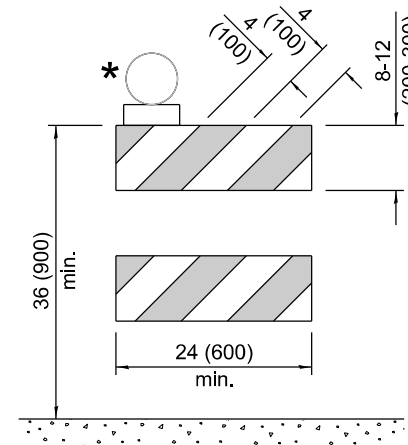

**TYPE II BARRICADE**

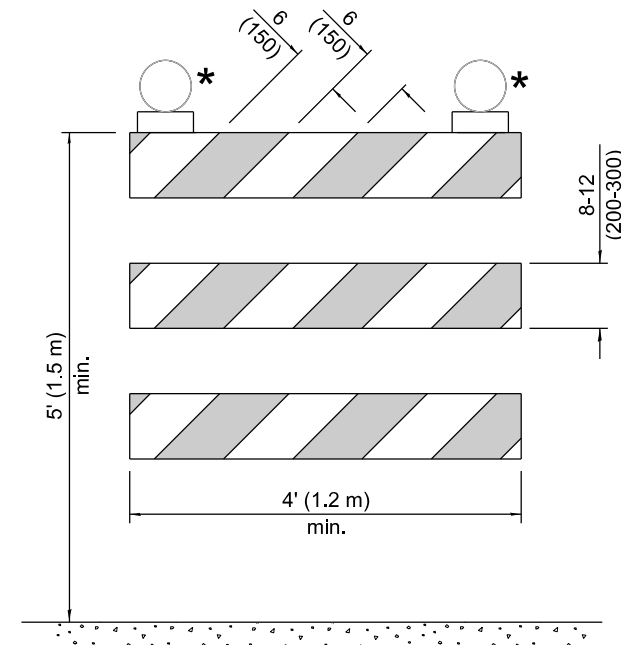

**TYPE III BARRICADE**

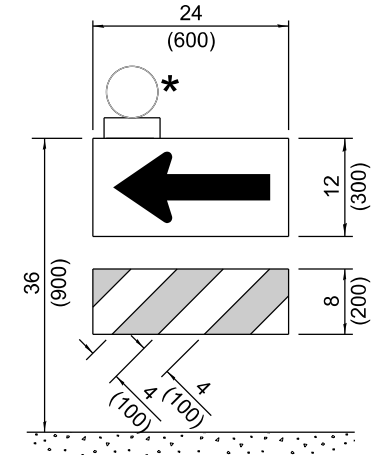

**DIRECTION INDICATOR BARRICADE**

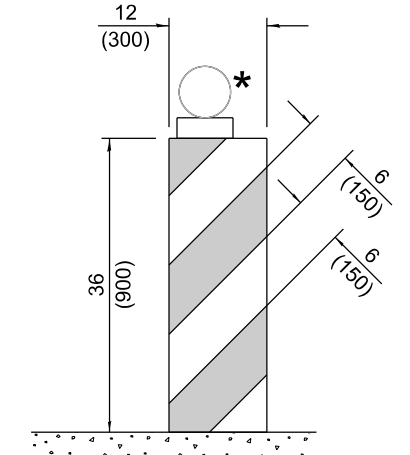

**VERTICAL BARRICADE**

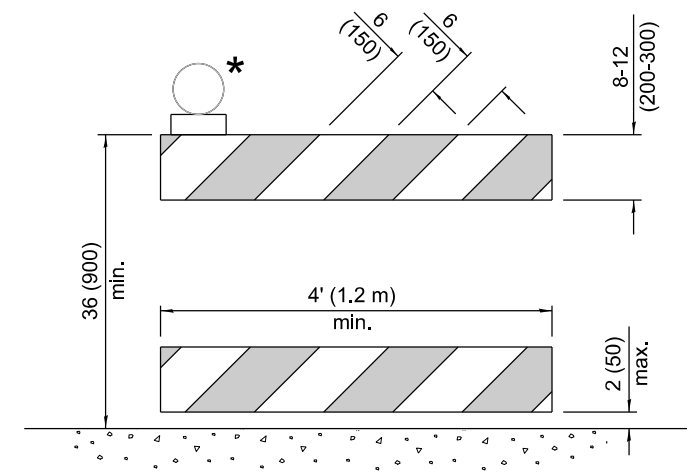

**DETECTABLE PEDESTRIAN CHANNELIZING BARRICADE**

\* Warning lights (if required)

**GENERAL NOTES**

All heights shown shall be measured above the pavement surface.

All dimensions are in inches (millimeters) unless otherwise shown.

DATE	REVISIONS
1-1-24	Revised Type III Barricade notes (sht. 3) & moved warning light on post mounted signs to top center.
1-1-19	Revised cones usage and added cones > 36" (900 mm) height.

**TRAFFIC CONTROL DEVICES**

(Sheet 1 of 3)

**STANDARD 701901-09**

Illinois Department of Transportation

APPROVED January 1, 2024

ENGINEER OF SAFETY PROGRAM AND ENGINEERING

APPROVED January 1, 2024

ENGINEER OF DESIGN AND ENVIRONMENT

ISSUED 1-1-13



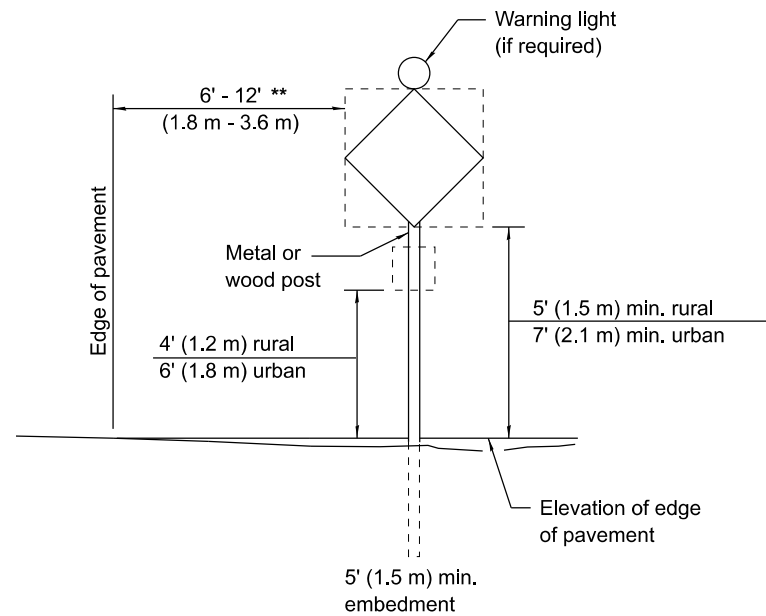

**POST MOUNTED SIGNS**

\*\* When curb or paved shoulder are present this dimension shall be 24 (600) to the face of curb or 6' (1.8 m) to the outside edge of the paved shoulder.

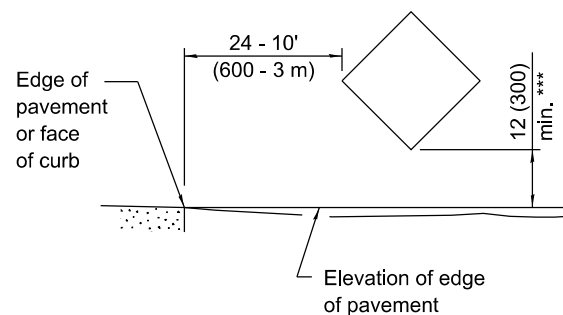

**SIGNS ON TEMPORARY SUPPORTS**

\*\*\* When work operations exceed four days, this dimension shall be 5' (1.5 m) min. If located behind other devices, the height shall be sufficient to be seen completely above the devices.

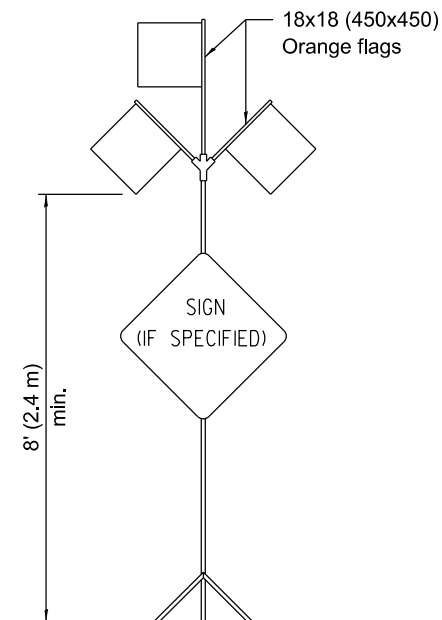

**HIGH LEVEL WARNING DEVICE**

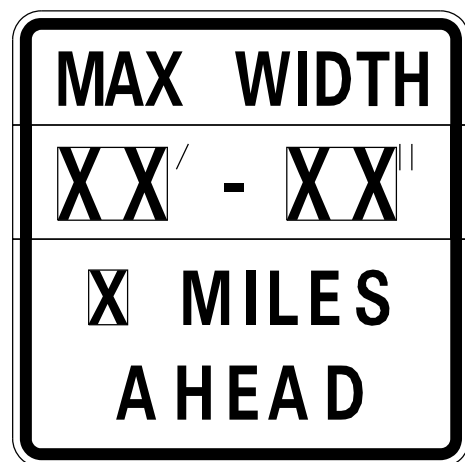

W12-1103-4848

**WIDTH RESTRICTION SIGN**

XX'-XX" width and X miles are variable.

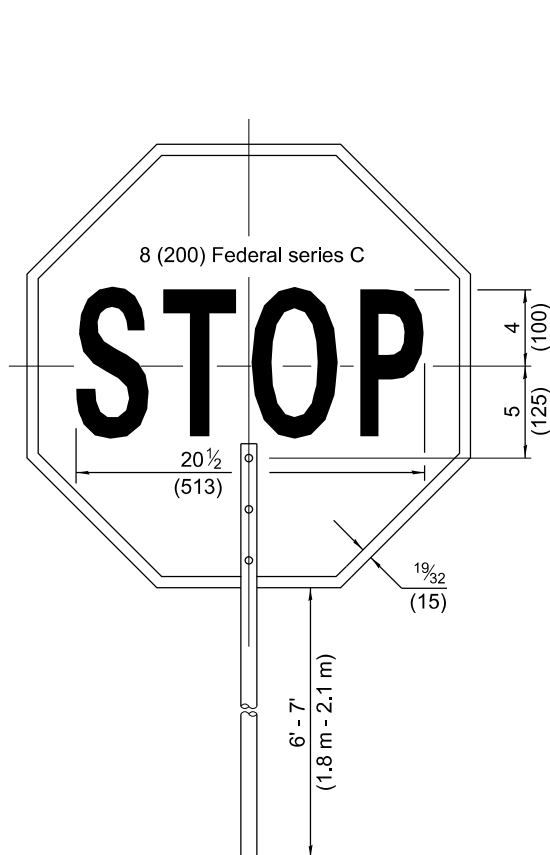

FRONT SIDE

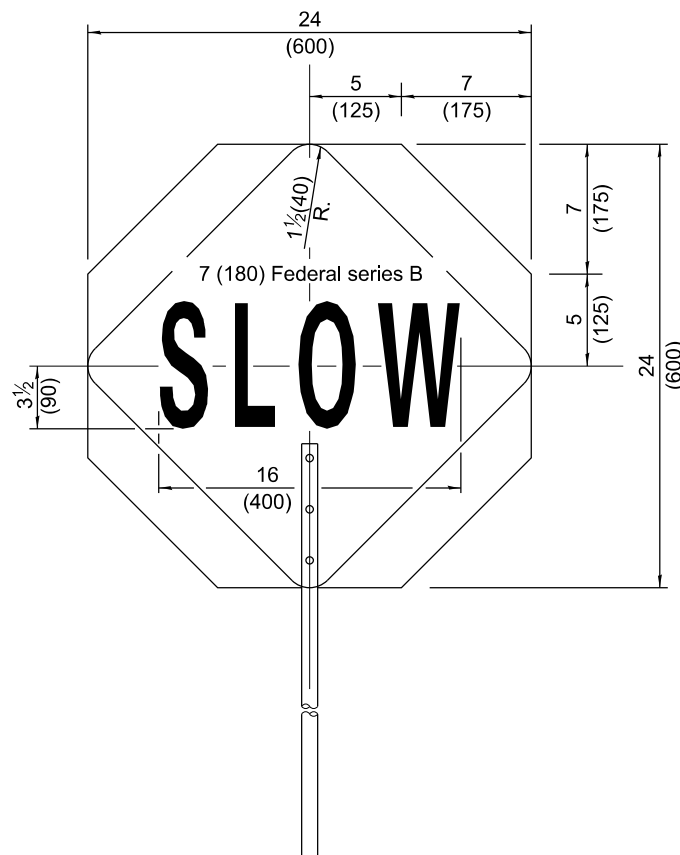

REVERSE SIDE

**FLAGGER TRAFFIC CONTROL SIGN**



G20-1104(0)-6036



G20-1105(0)-6024

This signing is required for all projects 2 miles (3200 m) or more in length.

ROAD CONSTRUCTION NEXT X MILES sign shall be placed 500' (150 m) in advance of project limits.

END CONSTRUCTION sign shall be erected at the end of the job unless another job is within 2 miles (3200 m).

Dual sign displays shall be utilized on multi-lane highways.

**WORK LIMIT SIGNING**

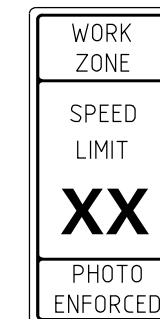

W21-1115(0)-3618

R2-1-3648

R10-1108p-3618 \*\*\*\*



R2-1106p-3618

Sign assembly as shown on Standards or as allowed by District Operations.

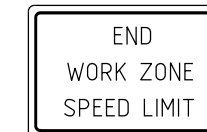

G20-1103-6036

This sign shall be used when the above sign assembly is used.

**HIGHWAY CONSTRUCTION SPEED ZONE SIGNS**

\*\*\*\* R10-1108p shall only be used along roadways under the jurisdiction of the State.

**TRAFFIC CONTROL DEVICES**

(Sheet 2 of 3)

STANDARD 701901-09

Illinois Department of Transportation

APPROVED January 1, 2024  
*[Signature]*  
 ENGINEER OF SAFETY PROGRAM AND ENGINEERING

APPROVED January 1, 2024  
*[Signature]*  
 ENGINEER OF DESIGN AND ENVIRONMENT

ISSUED 1-1-13

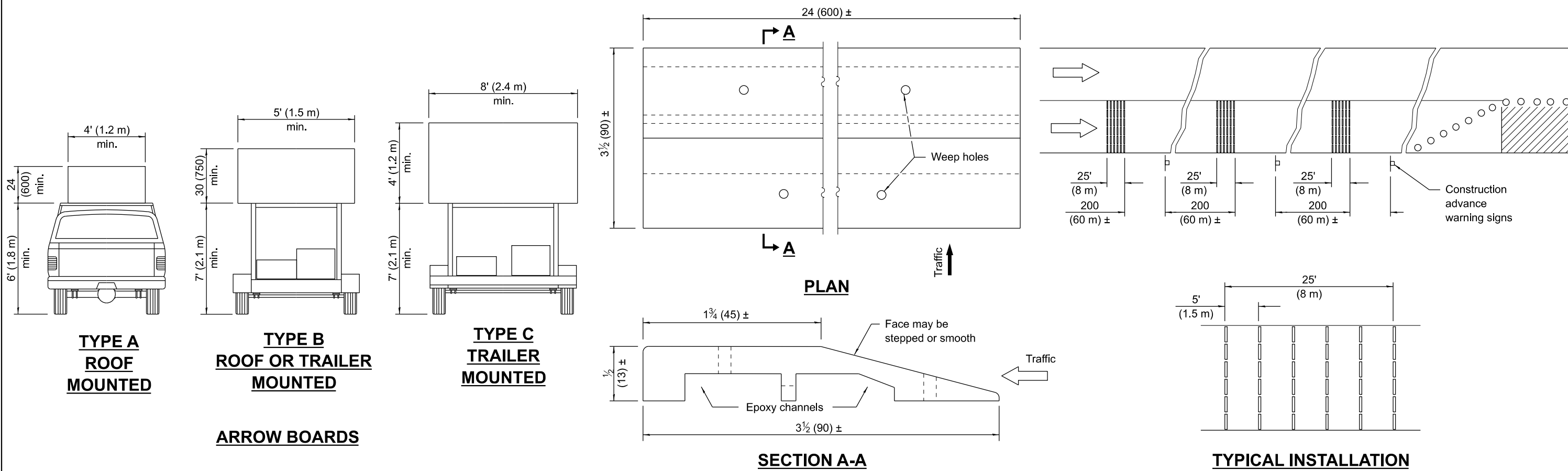

**TEMPORARY RUMBLE STRIPS**

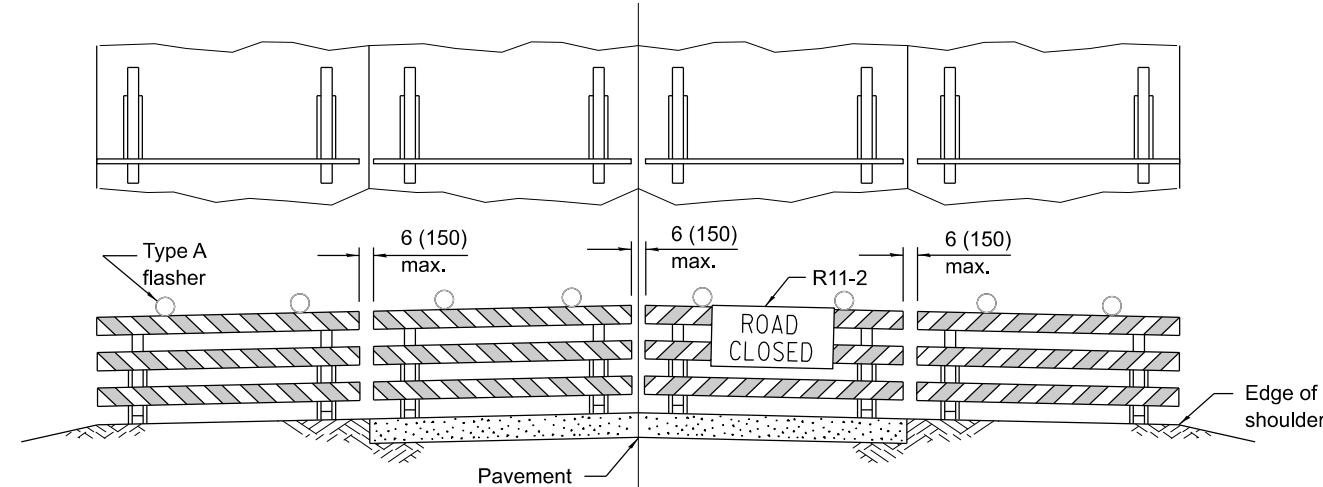

**ROAD CLOSED TO ALL TRAFFIC**  
 ReflectORIZED striping may be omitted on the back side of the barricades.

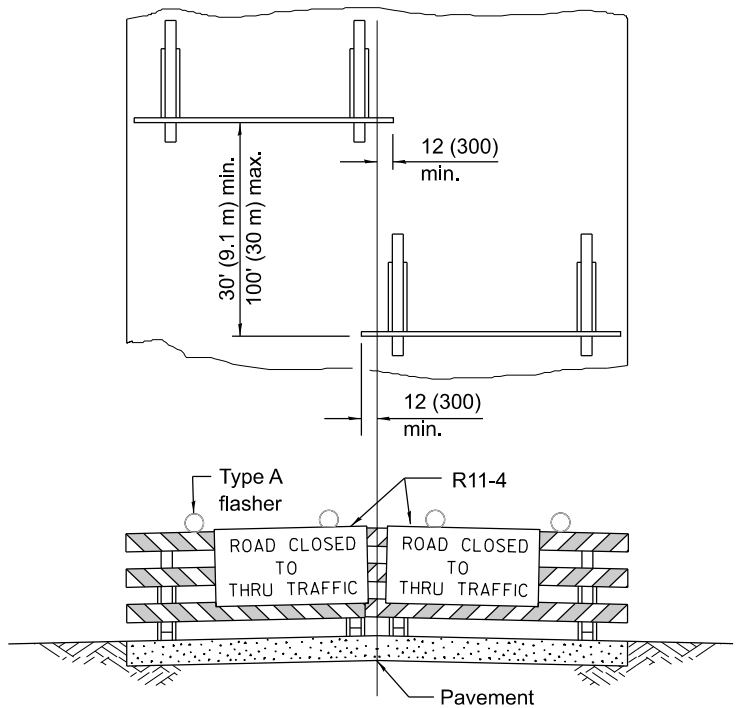

**ROAD CLOSED TO THRU TRAFFIC**  
 ReflectORIZED striping shall appear on both sides of the barricades.

**TYPICAL APPLICATIONS OF TYPE III BARRICADES CLOSING A ROAD**

If a Type III barricade with an attached sign panel which meets NCHRP 350 or MASH is not available, the sign may be mounted on an NCHRP 350 or MASH temporary sign support directly in front of the barricade.

Illinois Department of Transportation

APPROVED January 1, 2024  
 ENGINEER OF SAFETY PROGRAM AND ENGINEERING

APPROVED January 1, 2024  
 ENGINEER OF DESIGN AND ENVIRONMENT

ISSUED 1-1-13

**TRAFFIC CONTROL DEVICES**

(Sheet 3 of 3)

**STANDARD 701901-09**

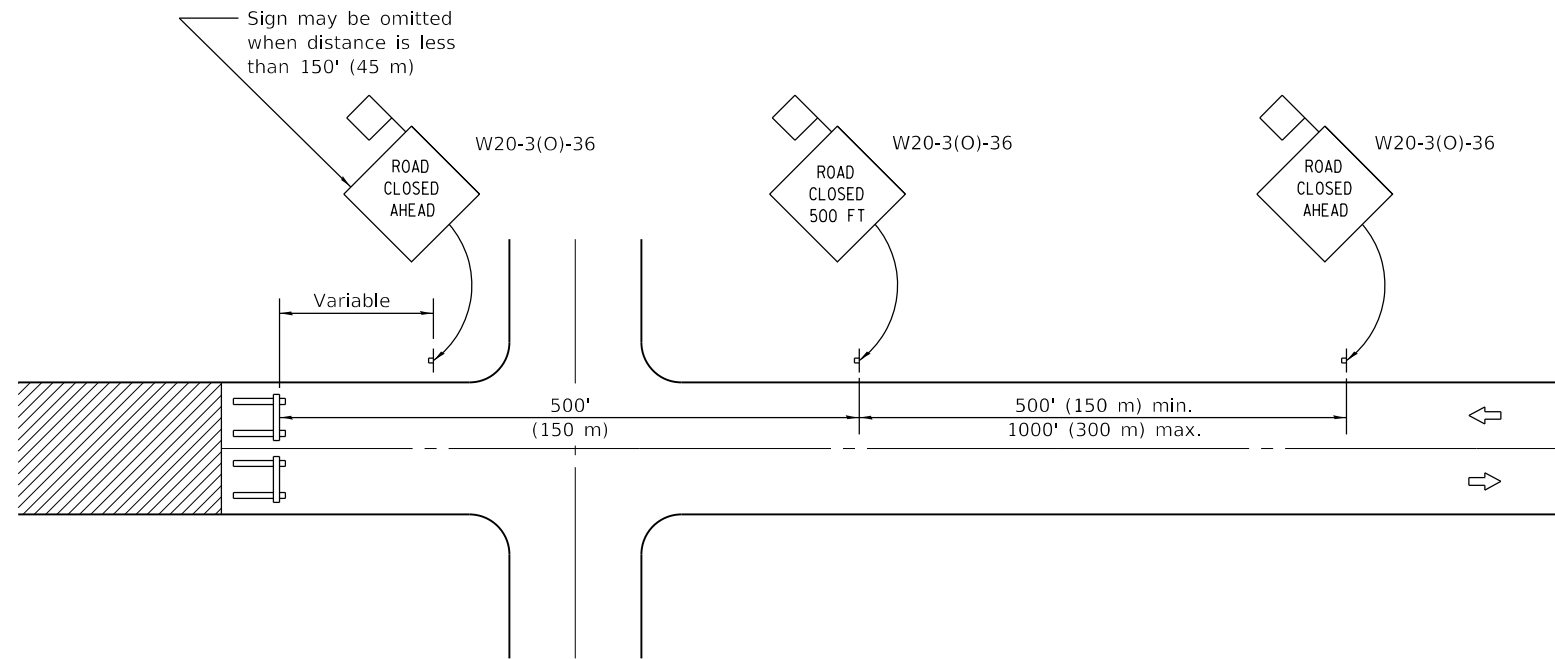

**CONDITION I**

When distance from closure to crossroad is less than 1500' (450 m)

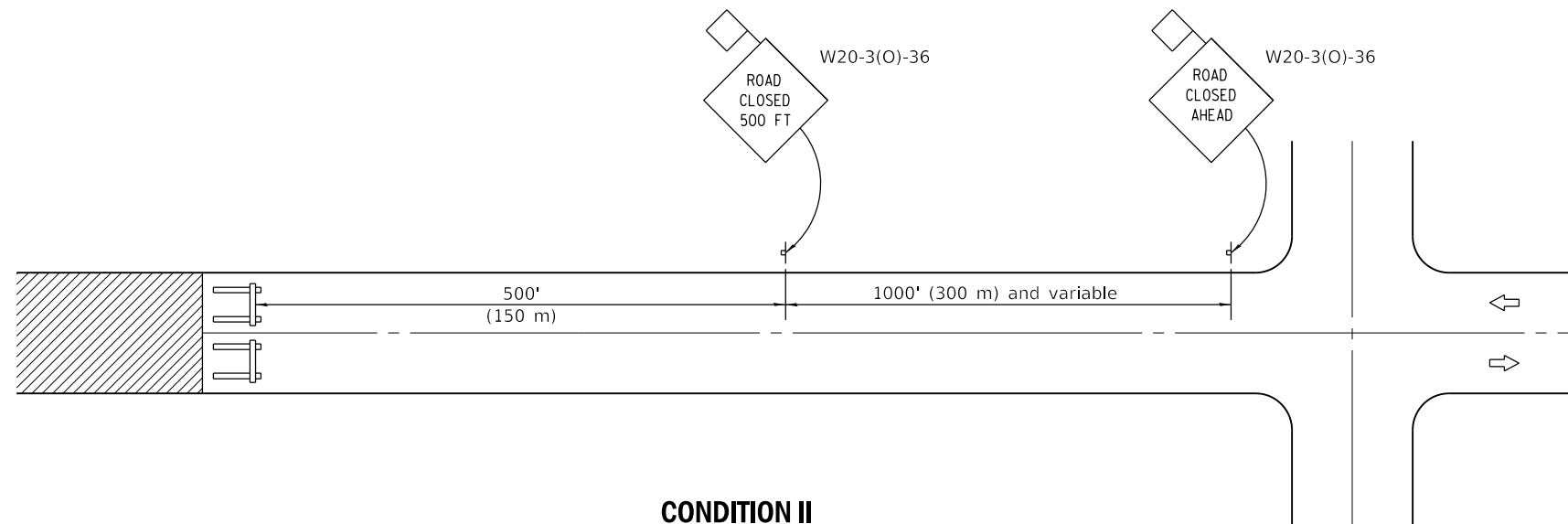

**CONDITION II**

When distance from closure to crossroad is greater than 1500' (450 m)

**SYMBOLS**



Work area



Type III Barricade



Sign with 18x18 (450x450) min. orange flag attached

**GENERAL NOTES**

Type III Barricades and R11-2-4830 signs shall be positioned as shown in "Road Closed To All Traffic" detail on Highway Standard 701901.

Two Type A Low Intensity Flashing Lights shall be used on each approach in advance of the work area during hours of darkness. One light shall be installed above the barricades and the other above the first advance warning sign.

All warning signs shall have minimum dimensions of 36 x 36 (900 x 900) and have a black legend on an orange reflectorized background.

When fluorescent signs are used, orange flags are not required.

Longitudinal dimensions may be adjusted to fit field conditions.

When the distance between the barricade and the intersection is between 1500' (450 m) and 2000' (600 m), the advance sign shall be placed at the intersection. When the distance between the barricade and the intersection is over 2000' (600 m), an additional sign shall be placed at the intersection. The additional sign shall give the distance to the barricade in miles or fractions of a mile.

All dimensions are in inches (millimeters) unless otherwise shown.

DATE	REVISIONS
1-1-12	Omitted two notes from GENERAL NOTES.
1-1-09	Switched units to English (metric).

**TYPICAL APPLICATION OF TRAFFIC CONTROL DEVICES FOR CONSTRUCTION ON RURAL LOCAL HIGHWAYS**

**STANDARD B.L.R. 21-9**

Illinois Department of Transportation

PASSED January 1, 2012  
*Danell Lewis*  
 ENGINEER OF LOCAL ROADS AND STREETS

APPROVED January 1, 2012  
*Scott S. S. S.*  
 ENGINEER OF DESIGN AND ENVIRONMENT

ISSUED 1-1-97