

**COMMITTEE REPORT**

HS-26-14

Mr. Chairman and Members of the Tazewell County Board:

Your Health Services Committee has considered the following RESOLUTION and recommends that it be adopted by the Board:

-----  
**RESOLUTION**

WHEREAS, the County's Health Services Committee recommends to the County Board that it enter into an agreement with the City of Delavan which will be entered into pursuant to Article 7, Section 10 of the Constitution of the State of Illinois of 1970; and

WHEREAS, The County agrees to provide the Animal and Rabies Control Services through the Tazewell County Animal & Rabies Control Department, its Administrator, Director, Deputies, and Agents effective January 1, 2026 for the period of one year; and

WHEREAS, the City of Delavan shall pay the County in the sum of \$3,994.76 for the services.

THEREFORE BE IT RESOLVED that the County Board approve this agreement.

BE IT FURTHER RESOLVED that the County Clerk notifies the County Board Office, Director of Animal Control, the Mayor of Delavan, and the Auditor of this action.

PASSED THIS 25<sup>th</sup> DAY OF MARCH, 2026.

ATTEST:

  
\_\_\_\_\_  
Tazewell County Clerk

  
\_\_\_\_\_  
Tazewell County Board Chairman

## INTERGOVERNMENTAL AGREEMENT

FOR

### ANIMAL & RABIES CONTROL SERVICES

THIS AGREEMENT, entered into this 1ST day of JANUARY, 2026, by and between the County of Tazewell, Illinois, a body politic and corporate (hereinafter referred to as "County") and the CITY OF DELAVAN, a unit of local government of the State of Illinois (hereinafter referred to as "Municipality"), this Agreement being entered into pursuant to Article 7, Section 10 of the Constitution of the State of Illinois of 1970.

In consideration of the payment by Municipality to the County of the sum of \$3,994.76, County agrees to provide the following Animal and Rabies Control services through the Tazewell County Animal & Rabies Control Department, its administrator, director, deputies, and agents as follows.

1. The County shall respond to calls and attempt to pick up animals running at large within the corporate limits of the Municipality between the hours of 8:00 a.m. and 4:00 p.m. seven (7) days a week, including weekends, but not including regularly scheduled County Holidays.
2. The County shall, on an emergency basis only, attempt to pick up animals running at large between the hours of 4:00 p.m. and 8:00 a.m. the next morning seven (7) days a week including weekends. During these times, the County has no obligations under this contract unless an emergency exists.
3. On regularly scheduled County Holidays, the County shall, on an emergency basis only, attempt to pick up dogs running at large both day and night. On regularly scheduled County Holidays, the County has no obligations under this contract unless an emergency exists.
4. For the purposes of this Agreement, an emergency shall be considered to include but not be limited to the following situations: a.) a person in immediate danger of an animal; b.) sick or injured domestic animals running at large; c.) sick or injured wild animals; d.) aggressive animals running at large; e.) animal bite reports; f.) providing necessary assistance to police, fire or EMS agencies; g.) wildlife present in the living quarters of a home/apartment/business; however removal of such wildlife from attics, walls or closed interior areas of a building of any kind is not provided by Tazewell County Animal Control; h.) animals in extreme elements without proper shelter or access to water (e.g. a dog in frigid temperature with no access to shelter or an animal left in a hot car.)
5. Emergency calls shall be placed by the CITY authorities or a citizen of the Municipality to either the Sheriff's Office (346-4141) or the Tazewell County Animal Control facility (925-3370). All calls placed by citizens, police, or governmental bodies will be answered as soon as possible during regularly scheduled working days between the hours of 8:00 a.m. and 4:00 p.m., Monday – Friday. Responses to emergency calls shall be made by the Tazewell County Animal Control Officer who is then on duty.

6. The County of Tazewell shall accept and make reasonable response to complaints of citizens concerning dogs running at large within the corporate limits of the Municipality.
7. The County may make regular and irregular patrols in the corporate limits of the Municipality one day a week at regular and irregular hours.
8. The County shall take custody and impound animals apprehended within the corporate limits of the Municipality at the Tazewell County Animal Control facility.
9. The County shall require proof of payment of Municipal reclamation fees to the Municipality by owners of animals sought to be redeemed before releasing said animal from custody.
10. The County shall provide humane treatment of animals removed from the corporate limits of the Municipality during the period of impounding.
11. For each animal impounded from within the municipality, the County shall provide a clear digital image of the animal to an agreed representative of the City, along with any relevant information about the animal, as soon as practicable. The City shall provide notice to the County of a single agreed representative for notification purposes.
12. The County shall make reasonable efforts to locate the owner or owners of any impounded animal providing that said animal is wearing a collar or rabies tag capable of identifying ownership. Upon identifying the owner or any such animal, an attempt will be made for immediate notification to said owner. A letter shall be mailed to the last known address of the owner notifying him of the impoundment of his animal. Said notification will give notice to the owner that the animal shall be destroyed, adopted, or transferred after the passage of seven (7) days if not reclaimed in accordance with law by the owner. An affidavit or testimony of the Administrator, or his authorized agent, who mails such notice shall be prima facie evidence of the receipt of said notice by the owner of such animal.
13. It is mutually understood and agreed that any animal apprehended from within the corporate limits of the Municipality and impounded at the Tazewell County Animal & Rabies Control Shelter, with respect to whom the owner is unknown but which unknown owner has failed to claim the animal within four (4) working days, shall be humanely dispatched or placed for adoption at the discretion of the Director of the Tazewell County Animal Control Department pursuant to the provisions of the Animal Control Act of the State of Illinois.
14. It is further understood and agreed that the consideration payable by the Municipality to the County may at the option of the Municipality be paid in equal monthly installments.
15. This Agreement shall become effective on the 1ST day of JANUARY, 2026 and shall be in full force and effect for a period of one (1) year.
16. This contract shall be governed by and interpreted in accordance with the laws of the State of Illinois. All relevant provisions of the laws of the State of Illinois applicable hereto and required to be reflected or set forth herein are incorporated by reference.
17. No waiver of any breach of this contract or any provision hereof shall constitute a waiver of any other or further breach of this contract or any provision thereof.

18. This contract is severable, and the invalidity, or unenforceability of any provision of this contract, or a part thereof, should not render the remainder of the contract invalid or unenforceable.
19. This contract may not be assigned by either party without the written consent of the other party.
20. This contract shall be binding upon the parties hereto and upon the successors in interest, assigns, representatives and heirs of such parties.
21. This contract shall not be amended unless in writing expressly stating that it constitutes an amendment to this contract, signed by the parties hereto.
22. The parties hereto agree that the foregoing constitutes all the agreement between the parties and in witness thereof the parties have affixed their respective signatures on the date above first note.

PASSED this 25<sup>th</sup> day of March 2026.

  
\_\_\_\_\_  
Tazewell County Board Chairman

ATTEST:

  
\_\_\_\_\_  
Tazewell County Clerk

MUNICIPALITY:

  
\_\_\_\_\_  
Mayor or Village Board President

TAZEWELL COUNTY ANIMAL CONTROL:

  
\_\_\_\_\_  
Director

Annual Amount: \$3,994.76

Triannual Amount: \$1,331.58

**COMMITTEE REPORT**

HS-26-13

Mr. Chairman and Members of the Tazewell County Board:

Your Health Services Committee has considered the following RESOLUTION and recommends that it be adopted by the Board:

-----  
**RESOLUTION**

WHEREAS, the County's Health Services Committee recommends to the County Board that it enter into an agreement with the City of Washington which will be entered into pursuant to Article 7, Section 10 of the Constitution of the State of Illinois of 1970; and

WHEREAS, The County agrees to provide the Animal and Rabies Control Services through the Tazewell County Animal & Rabies Control Department, its Administrator, Director, Deputies, and Agents effective January 1, 2026 for the period of one year; and

WHEREAS, the City of Washington shall pay the County in the sum of \$20,558.29 for the services.

THEREFORE BE IT RESOLVED that the County Board approve this agreement.

BE IT FURTHER RESOLVED that the County Clerk notifies the County Board Office, Director of Animal Control, the Mayor of Washington, and the Auditor of this action.

PASSED THIS 25<sup>th</sup> DAY OF MARCH, 2026.

ATTEST:

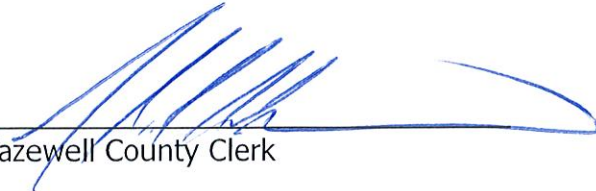
  
\_\_\_\_\_  
Tazewell County Clerk

  
\_\_\_\_\_  
Tazewell County Board Chairman

**INTERGOVERNMENTAL AGREEMENT**  
**FOR**  
**ANIMAL & RABIES CONTROL SERVICES**

THIS AGREEMENT, entered into this 1ST day of JANUARY, 2026, by and between the County of Tazewell, Illinois, a body politic and corporate (hereinafter referred to as "County") and the CITY OF WASHINGTON, a unit of local government of the State of Illinois (hereinafter referred to as "Municipality"), this Agreement being entered into pursuant to Article 7, Section 10 of the Constitution of the State of Illinois of 1970.

In consideration of the payment by Municipality to the County of the sum of \$20,558.29, County agrees to provide the following Animal and Rabies Control services through the Tazewell County Animal & Rabies Control Department, its administrator, director, deputies, and agents as follows.

1. The County shall respond to calls and attempt to pick up animals running at large within the corporate limits of the Municipality between the hours of 8:00 a.m. and 4:00 p.m. seven (7) days a week, including weekends, but not including regularly scheduled County Holidays.
2. The County shall, on an emergency basis only, attempt to pick up animals running at large between the hours of 4:00 p.m. and 8:00 a.m. the next morning seven (7) days a week including weekends. During these times, the County has no obligations under this contract unless an emergency exists.
3. On regularly scheduled County Holidays, the County shall, on an emergency basis only, attempt to pick up dogs running at large both day and night. On regularly scheduled County Holidays, the County has no obligations under this contract unless an emergency exists.
4. For the purposes of this Agreement, an emergency shall be considered to include but not be limited to the following situations: a.) a person in immediate danger of an animal; b.) sick or injured domestic animals running at large; c.) sick or injured wild animals; d.) aggressive animals running at large; e.) animal bite reports; f.) providing necessary assistance to police, fire or EMS agencies; g.) wildlife present in the living quarters of a home/apartment/business; however removal of such wildlife from attics, walls or closed interior areas of a building of any kind is not provided by Tazewell County Animal Control; h.) animals in extreme elements without proper shelter or access to water (e.g. a dog in frigid temperature with no access to shelter or an animal left in a hot car.)
5. Emergency calls shall be placed by the CITY authorities or a citizen of the Municipality to either the Sheriff's Office (346-4141) or the Tazewell County Animal Control facility (925-3370). All calls placed by citizens, police, or governmental bodies will be answered as soon as possible during regularly scheduled working days between the hours of 8:00 a.m. and 4:00 p.m., Monday – Friday. Responses to emergency calls shall be made by the Tazewell County Animal Control Officer who is then on duty.

6. The County of Tazewell shall accept and make reasonable response to complaints of citizens concerning dogs running at large within the corporate limits of the Municipality.
7. The County may make regular and irregular patrols in the corporate limits of the Municipality one day a week at regular and irregular hours.
8. The County shall take custody and impound animals apprehended within the corporate limits of the Municipality at the Tazewell County Animal Control facility.
9. The County shall require proof of payment of Municipal reclamation fees to the Municipality by owners of animals sought to be redeemed before releasing said animal from custody.
10. The County shall provide humane treatment of animals removed from the corporate limits of the Municipality during the period of impounding.
11. The County shall make reasonable efforts to locate the owner or owners of any impounded animal providing that said animal is wearing a collar or rabies tag capable of identifying ownership. Upon identifying the owner or any such animal, an attempt will be made for immediate notification to said owner. A letter shall be mailed to the last known address of the owner notifying him of the impoundment of his animal. Said notification will give notice to the owner that the animal shall be destroyed, adopted, or transferred after the passage of seven (7) days if not reclaimed in accordance with law by the owner. An affidavit or testimony of the Administrator, or his authorized agent, who mails such notice shall be prima facie evidence of the receipt of said notice by the owner of such animal.
12. It is mutually understood and agreed that any animal apprehended from within the corporate limits of the Municipality and impounded at the Tazewell County Animal & Rabies Control Shelter, with respect to whom the owner is unknown but which unknown owner has failed to claim the animal within four (4) working days, shall be humanely dispatched or placed for adoption at the discretion of the Director of the Tazewell County Animal Control Department pursuant to the provisions of the Animal Control Act of the State of Illinois.
13. It is further understood and agreed that the consideration payable by the Municipality to the County may at the option of the Municipality be paid in equal monthly installments.
14. This Agreement shall become effective on the **1ST** day of **JANUARY, 2026** and shall be in full force and effect for a period of one (1) year.
15. This contract shall be governed by and interpreted in accordance with the laws of the State of Illinois. All relevant provisions of the laws of the State of Illinois applicable hereto and required to be reflected or set forth herein are incorporated by reference.
16. No waiver of any breach of this contract or any provision hereof shall constitute a waiver of any other or further breach of this contract or any provision thereof.
17. This contract is severable, and the invalidity, or unenforceability of any provision of this contract, or a part thereof, should not render the remainder of the contract invalid or unenforceable.
18. This contract may not be assigned by either party without the written consent of the other party.

19. This contract shall be binding upon the parties hereto and upon the successors in interest, assigns, representatives and heirs of such parties.
20. This contract shall not be amended unless in writing expressly stating that it constitutes an amendment to this contract, signed by the parties hereto.
21. The parties hereto agree that the foregoing constitutes all the agreement between the parties and in witness thereof the parties have affixed their respective signatures on the date above first note.

PASSED this 25<sup>th</sup> day of March 2020

  
\_\_\_\_\_  
Tazewell County Board Chairman

ATTEST:

  
\_\_\_\_\_  
Tazewell County Clerk

MUNICIPALITY:

  
\_\_\_\_\_  
Mayor or Village Board President

TAZEWELL COUNTY ANIMAL CONTROL:

  
\_\_\_\_\_  
Director

Annual Amount: \$20,558.29

Triannual Amount: \$6,852.76

**COMMITTEE REPORT**

Mr. Chairman and Members of the Tazewell County Board:

Your Health Services Committee has considered the following RESOLUTION and recommends that it be adopted by the Board:

-----  
**RESOLUTION**

WHEREAS, the County's Health Services Committee recommends to the County Board that it enter into an agreement with the Village of Tremont which will be entered into pursuant to Article 7, Section 10 of the Constitution of the State of Illinois of 1970; and

WHEREAS, the County agrees to provide the Animal and Rabies Control Services through the Tazewell County Animal & Rabies Control Department, its Administrator, Director, Deputies, and Agents effective January 1, 2026 for the period of one year; and

WHEREAS, the Village of Tremont shall pay the County the sum of \$3,084.23 for the services.

THEREFORE BE IT RESOLVED that the County Board approve this agreement.

BE IT FURTHER RESOLVED that the County Clerk notifies the County Board Office, Director of Animal Control, the Mayor of Tremont and the Auditor of this action.

PASSED THIS 25<sup>th</sup> DAY OF MARCH, 2026.

ATTEST:

  
\_\_\_\_\_  
Tazewell County Clerk

  
\_\_\_\_\_  
Tazewell County Board Chairman

## INTERGOVERNMENTAL AGREEMENT

FOR

### ANIMAL & RABIES CONTROL SERVICES

THIS AGREEMENT, entered into this 1ST day of JANUARY, 2026, by and between the County of Tazewell, Illinois, a body politic and corporate (hereinafter referred to as "County") and the VILLAGE OF TREMONT, a unit of local government of the State of Illinois (hereinafter referred to as "Municipality"), this Agreement being entered into pursuant to Article 7, Section 10 of the Constitution of the State of Illinois of 1970.

In consideration of the payment by Municipality to the County of the sum of \$3,084.23, County agrees to provide the following Animal and Rabies Control services through the Tazewell County Animal & Rabies Control Department, its administrator, director, deputies, and agents as follows.

1. The County shall respond to calls and attempt to pick up animals running at large within the corporate limits of the Municipality between the hours of 8:00 a.m. and 4:00 p.m. seven (7) days a week, including weekends, but not including regularly scheduled County Holidays.
2. The County shall, on an emergency basis only, attempt to pick up animals running at large between the hours of 4:00 p.m. and 8:00 a.m. the next morning seven (7) days a week including weekends. During these times, the County has no obligations under this contract unless an emergency exists.
3. On regularly scheduled County Holidays, the County shall, on an emergency basis only, attempt to pick up dogs running at large both day and night. On regularly scheduled County Holidays, the County has no obligations under this contract unless an emergency exists.
4. For the purposes of this Agreement, an emergency shall be considered to include but not be limited to the following situations: a.) a person in immediate danger of an animal; b.) sick or injured domestic animals running at large; c.) sick or injured wild animals; d.) aggressive animals running at large; e.) animal bite reports; f.) providing necessary assistance to police, fire or EMS agencies; g.) wildlife present in the living quarters of a home/apartment/business; however removal of such wildlife from attics, walls or closed interior areas of a building of any kind is not provided by Tazewell County Animal Control; h.) animals in extreme elements without proper shelter or access to water (e.g. a dog in frigid temperature with no access to shelter or an animal left in a hot car.)
5. Emergency calls shall be placed by the VILLAGE authorities or a citizen of the Municipality to either the Sheriff's Office (346-4141) or the Tazewell County Animal Control facility (925-3370). All calls placed by citizens, police, or governmental bodies will be answered as soon as possible during regularly scheduled working days between the hours of 8:00 a.m. and 4:00 p.m., Monday – Friday. Responses to emergency calls shall be made by the Tazewell County Animal Control Officer who is then on duty.

6. The County of Tazewell shall accept and make reasonable response to complaints of citizens concerning dogs running at large within the corporate limits of the Municipality.
7. The County may make regular and irregular patrols in the corporate limits of the Municipality one day a week at regular and irregular hours.
8. The County shall take custody and impound animals apprehended within the corporate limits of the Municipality at the Tazewell County Animal Control facility.
9. The County shall require proof of payment of Municipal reclamation fees to the Municipality by owners of animals sought to be redeemed before releasing said animal from custody.
10. The County shall provide humane treatment of animals removed from the corporate limits of the Municipality during the period of impounding.
11. The County shall make reasonable efforts to locate the owner or owners of any impounded animal providing that said animal is wearing a collar or rabies tag capable of identifying ownership. Upon identifying the owner or any such animal, an attempt will be made for immediate notification to said owner. A letter shall be mailed to the last known address of the owner notifying him of the impoundment of his animal. Said notification will give notice to the owner that the animal shall be destroyed, adopted, or transferred after the passage of seven (7) days if not reclaimed in accordance with law by the owner. An affidavit or testimony of the Administrator, or his authorized agent, who mails such notice shall be prima facie evidence of the receipt of said notice by the owner of such animal.
12. It is mutually understood and agreed that any animal apprehended from within the corporate limits of the Municipality and impounded at the Tazewell County Animal & Rabies Control Shelter, with respect to whom the owner is unknown but which unknown owner has failed to claim the animal within four (4) working days, shall be humanely dispatched or placed for adoption at the discretion of the Director of the Tazewell County Animal Control Department pursuant to the provisions of the Animal Control Act of the State of Illinois.
13. It is further understood and agreed that the consideration payable by the Municipality to the County may at the option of the Municipality be paid in equal monthly installments.
14. This Agreement shall become effective on the **1ST** day of **JANUARY, 2026** and shall be in full force and effect for a period of one (1) year.
15. This contract shall be governed by and interpreted in accordance with the laws of the State of Illinois. All relevant provisions of the laws of the State of Illinois applicable hereto and required to be reflected or set forth herein are incorporated by reference.
16. No waiver of any breach of this contract or any provision hereof shall constitute a waiver of any other or further breach of this contract or any provision thereof.
17. This contract is severable, and the invalidity, or unenforceability of any provision of this contract, or a part thereof, should not render the remainder of the contract invalid or unenforceable.
18. This contract may not be assigned by either party without the written consent of the other party.

19. This contract shall be binding upon the parties hereto and upon the successors in interest, assigns, representatives and heirs of such parties.
20. This contract shall not be amended unless in writing expressly stating that it constitutes an amendment to this contract, signed by the parties hereto.
21. The parties hereto agree that the foregoing constitutes all the agreement between the parties and in witness thereof the parties have affixed their respective signatures on the date above first note.

PASSED this 25<sup>th</sup> day of March 2026.

  
\_\_\_\_\_  
Tazewell County Board Chairman

ATTEST:

  
\_\_\_\_\_  
Tazewell County Clerk

MUNICIPALITY:

  
\_\_\_\_\_  
Mayor or Village Board President

TAZEWELL COUNTY ANIMAL CONTROL:

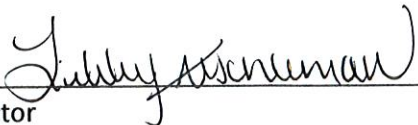
  
\_\_\_\_\_  
Director

Annual Amount: \$3,084.23

Triannual Amount: \$1,028.07

**COMMITTEE REPORT**

HS-26-16

Mr. Chairman and Members of the Tazewell County Board:

Your Health Services Committee has considered the following RESOLUTION and recommends that it be adopted by the Board:

-----  
**RESOLUTION**

WHEREAS, the County's Health Services Committee recommends to the County Board that it enter into an agreement with the Village of Armington which will be entered into pursuant to Article 7, Section 10 of the Constitution of the State of Illinois of 1970; and

WHEREAS, The County agrees to provide the Animal and Rabies Control Services through the Tazewell County Animal & Rabies Control Department, its Administrator, Director, Deputies, and Agents effective January 1, 2026 for the period of one year; and

WHEREAS, the Village of Armington shall pay the County in the sum of \$715.40 for the services.

THEREFORE BE IT RESOLVED that the County Board approve this agreement.

BE IT FURTHER RESOLVED that the County Clerk notifies the County Board Office, Director of Animal Control, the Armington Village President and the Auditor of this action.

PASSED THIS 25<sup>th</sup> DAY OF MARCH, 2026.

ATTEST:

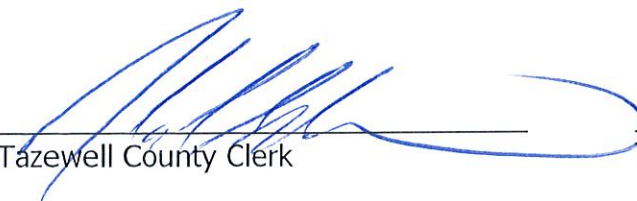
  
\_\_\_\_\_  
Tazewell County Clerk

  
\_\_\_\_\_  
Tazewell County Board Chairman

**INTERGOVERNMENTAL AGREEMENT**  
**FOR**  
**ANIMAL & RABIES CONTROL SERVICES**

THIS AGREEMENT, entered into this 1ST day of JANUARY, 2026, by and between the County of Tazewell, Illinois, a body politic and corporate (hereinafter referred to as "County") and the VILLAGE OF ARMINGTON, a unit of local government of the State of Illinois (hereinafter referred to as "Municipality"), this Agreement being entered into pursuant to Article 7, Section 10 of the Constitution of the State of Illinois of 1970.

In consideration of the payment by Municipality to the County of the sum of \$715.40, County agrees to provide the following Animal and Rabies Control services through the Tazewell County Animal & Rabies Control Department, its administrator, director, deputies, and agents as follows.

1. The County shall respond to calls and attempt to pick up animals running at large within the corporate limits of the Municipality between the hours of 8:00 a.m. and 4:00 p.m. seven (7) days a week, including weekends, but not including regularly scheduled County Holidays.
2. The County shall, on an emergency basis only, attempt to pick up animals running at large between the hours of 4:00 p.m. and 8:00 a.m. the next morning seven (7) days a week including weekends. During these times, the County has no obligations under this contract unless an emergency exists.
3. On regularly scheduled County Holidays, the County shall, on an emergency basis only, attempt to pick up dogs running at large both day and night. On regularly scheduled County Holidays, the County has no obligations under this contract unless an emergency exists.
4. For the purposes of this Agreement, an emergency shall be considered to include but not be limited to the following situations: a.) a person in immediate danger of an animal; b.) sick or injured domestic animals running at large; c.) sick or injured wild animals; d.) aggressive animals running at large; e.) animal bite reports; f.) providing necessary assistance to police, fire or EMS agencies; g.) wildlife present in the living quarters of a home/apartment/business; however removal of such wildlife from attics, walls or closed interior areas of a building of any kind is not provided by Tazewell County Animal Control; h.) animals in extreme elements without proper shelter or access to water (e.g. a dog in frigid temperature with no access to shelter or an animal left in a hot car.)
5. Emergency calls shall be placed by the VILLAGE authorities or a citizen of the Municipality to either the Sheriff's Office (346-4141) or the Tazewell County Animal Control facility (925-3370). All calls placed by citizens, police, or governmental bodies will be answered as soon as possible during regularly scheduled working days between the hours of 8:00 a.m. and 4:00 p.m., Monday – Friday. Responses to emergency calls shall be made by the Tazewell County Animal Control Officer who is then on duty.

6. The County of Tazewell shall accept and make reasonable response to complaints of citizens concerning dogs running at large within the corporate limits of the Municipality.
7. The County may make regular and irregular patrols in the corporate limits of the Municipality one day a week at regular and irregular hours.
8. The County shall take custody and impound animals apprehended within the corporate limits of the Municipality at the Tazewell County Animal Control facility.
9. The County shall require proof of payment of Municipal reclamation fees to the Municipality by owners of animals sought to be redeemed before releasing said animal from custody.
10. The County shall provide humane treatment of animals removed from the corporate limits of the Municipality during the period of impounding.
11. The County shall make reasonable efforts to locate the owner or owners of any impounded animal providing that said animal is wearing a collar or rabies tag capable of identifying ownership. Upon identifying the owner or any such animal, an attempt will be made for immediate notification to said owner. A letter shall be mailed to the last known address of the owner notifying him of the impoundment of his animal. Said notification will give notice to the owner that the animal shall be destroyed, adopted, or transferred after the passage of seven (7) days if not reclaimed in accordance with law by the owner. An affidavit or testimony of the Administrator, or his authorized agent, who mails such notice shall be prima facie evidence of the receipt of said notice by the owner of such animal.
12. It is mutually understood and agreed that any animal apprehended from within the corporate limits of the Municipality and impounded at the Tazewell County Animal & Rabies Control Shelter, with respect to whom the owner is unknown but which unknown owner has failed to claim the animal within four (4) working days, shall be humanely dispatched or placed for adoption at the discretion of the Director of the Tazewell County Animal Control Department pursuant to the provisions of the Animal Control Act of the State of Illinois.
13. It is further understood and agreed that the consideration payable by the Municipality to the County may at the option of the Municipality be paid in equal monthly installments.
14. This Agreement shall become effective on the 1ST day of JANUARY, 2026 and shall be in full force and effect for a period of one (1) year.
15. This contract shall be governed by and interpreted in accordance with the laws of the State of Illinois. All relevant provisions of the laws of the State of Illinois applicable hereto and required to be reflected or set forth herein are incorporated by reference.
16. No waiver of any breach of this contract or any provision hereof shall constitute a waiver of any other or further breach of this contract or any provision thereof.
17. This contract is severable, and the invalidity, or unenforceability of any provision of this contract, or a part thereof, should not render the remainder of the contract invalid or unenforceable.
18. This contract may not be assigned by either party without the written consent of the other party.

19. This contract shall be binding upon the parties hereto and upon the successors in interest, assigns, representatives and heirs of such parties.
20. This contract shall not be amended unless in writing expressly stating that it constitutes an amendment to this contract, signed by the parties hereto.
21. The parties hereto agree that the foregoing constitutes all the agreement between the parties and in witness thereof the parties have affixed their respective signatures on the date above first note.

PASSED this 12<sup>th</sup> day of November 2025

  
\_\_\_\_\_  
Tazewell County Board Chairman

ATTEST:

  
\_\_\_\_\_  
Tazewell County Clerk

MUNICIPALITY:

  
\_\_\_\_\_  
Mayor or Village Board President

TAZEWELL COUNTY ANIMAL CONTROL:

  
\_\_\_\_\_  
Director

Annual Amount: \$715.40

**COMMITTEE REPORT**

HS-26-17

Mr. Chairman and Members of the Tazewell County Board:

Your Health Services Committee has considered the following RESOLUTION and recommends that it be adopted by the Board:

-----  
**RESOLUTION**

WHEREAS, the County's Health Services Committee recommends to the County Board that it enter into an agreement with the Village of Hopedale which will be entered into pursuant to Article 7, Section 10 of the Constitution of the State of Illinois of 1970; and

WHEREAS, the County agrees to provide the Animal and Rabies Control Services through the Tazewell County Animal & Rabies Control Department, its Administrator, Director, Deputies, and Agents effective January 1, 2026 for the period of one year; and

WHEREAS, the Village of Hopedale shall pay the County the sum of \$1,325.67 for the services.

THEREFORE BE IT RESOLVED that the County Board approve this agreement.

BE IT FURTHER RESOLVED that the County Clerk notifies the County Board Office, Director of Animal Control, the Hopedale Village President and the Auditor of this action.

PASSED THIS 25<sup>th</sup> DAY OF MARCH, 2026.

ATTEST:

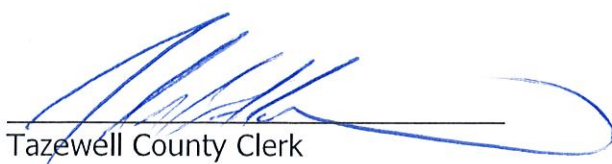
  
\_\_\_\_\_  
Tazewell County Clerk

  
\_\_\_\_\_  
Tazewell County Board Chairman

**INTERGOVERNMENTAL AGREEMENT**  
**FOR**  
**ANIMAL & RABIES CONTROL SERVICES**

THIS AGREEMENT, entered into this 1ST day of JANUARY, 2026, by and between the County of Tazewell, Illinois, a body politic and corporate (hereinafter referred to as "County") and the VILLAGE OF HOPEDALE, a unit of local government of the State of Illinois (hereinafter referred to as "Municipality"), this Agreement being entered into pursuant to Article 7, Section 10 of the Constitution of the State of Illinois of 1970.

In consideration of the payment by Municipality to the County of the sum of \$1,325.67, County agrees to provide the following Animal and Rabies Control services through the Tazewell County Animal & Rabies Control Department, its administrator, director, deputies, and agents as follows.

1. The County shall respond to calls and attempt to pick up animals running at large within the corporate limits of the Municipality between the hours of 8:00 a.m. and 4:00 p.m. seven (7) days a week, including weekends, but not including regularly scheduled County Holidays.
2. The County shall, on an emergency basis only, attempt to pick up animals running at large between the hours of 4:00 p.m. and 8:00 a.m. the next morning seven (7) days a week including weekends. During these times, the County has no obligations under this contract unless an emergency exists.
3. On regularly scheduled County Holidays, the County shall, on an emergency basis only, attempt to pick up dogs running at large both day and night. On regularly scheduled County Holidays, the County has no obligations under this contract unless an emergency exists.
4. For the purposes of this Agreement, an emergency shall be considered to include but not be limited to the following situations: a.) a person in immediate danger of an animal; b.) sick or injured domestic animals running at large; c.) sick or injured wild animals; d.) aggressive animals running at large; e.) animal bite reports; f.) providing necessary assistance to police, fire or EMS agencies; g.) wildlife present in the living quarters of a home/apartment/business; however removal of such wildlife from attics, walls or closed interior areas of a building of any kind is not provided by Tazewell County Animal Control; h.) animals in extreme elements without proper shelter or access to water (e.g. a dog in frigid temperature with no access to shelter or an animal left in a hot car.)
5. Emergency calls shall be placed by the VILLAGE authorities or a citizen of the Municipality to either the Sheriff's Office (346-4141) or the Tazewell County Animal Control facility (925-3370). All calls placed by citizens, police, or governmental bodies will be answered as soon as possible during regularly scheduled working days between the hours of 8:00 a.m. and 4:00 p.m., Monday – Friday. Responses to emergency calls shall be made by the Tazewell County Animal Control Officer who is then on duty.

6. The County of Tazewell shall accept and make reasonable response to complaints of citizens concerning dogs running at large within the corporate limits of the Municipality.
7. The County may make regular and irregular patrols in the corporate limits of the Municipality one day a week at regular and irregular hours.
8. The County shall take custody and impound animals apprehended within the corporate limits of the Municipality at the Tazewell County Animal Control facility.
9. The County shall require proof of payment of Municipal reclamation fees to the Municipality by owners of animals sought to be redeemed before releasing said animal from custody.
10. The County shall provide humane treatment of animals removed from the corporate limits of the Municipality during the period of impounding.
11. The County shall make reasonable efforts to locate the owner or owners of any impounded animal providing that said animal is wearing a collar or rabies tag capable of identifying ownership. Upon identifying the owner or any such animal, an attempt will be made for immediate notification to said owner. A letter shall be mailed to the last known address of the owner notifying him of the impoundment of his animal. Said notification will give notice to the owner that the animal shall be destroyed, adopted, or transferred after the passage of seven (7) days if not reclaimed in accordance with law by the owner. An affidavit or testimony of the Administrator, or his authorized agent, who mails such notice shall be prima facie evidence of the receipt of said notice by the owner of such animal.
12. It is mutually understood and agreed that any animal apprehended from within the corporate limits of the Municipality and impounded at the Tazewell County Animal & Rabies Control Shelter, with respect to whom the owner is unknown but which unknown owner has failed to claim the animal within four (4) working days, shall be humanely dispatched or placed for adoption at the discretion of the Director of the Tazewell County Animal Control Department pursuant to the provisions of the Animal Control Act of the State of Illinois.
13. It is further understood and agreed that the consideration payable by the Municipality to the County may at the option of the Municipality be paid in equal monthly installments.
14. This Agreement shall become effective on the 1ST day of JANUARY, 2026 and shall be in full force and effect for a period of one (1) year.
15. This contract shall be governed by and interpreted in accordance with the laws of the State of Illinois. All relevant provisions of the laws of the State of Illinois applicable hereto and required to be reflected or set forth herein are incorporated by reference.
16. No waiver of any breach of this contract or any provision hereof shall constitute a waiver of any other or further breach of this contract or any provision thereof.
17. This contract is severable, and the invalidity, or unenforceability of any provision of this contract, or a part thereof, should not render the remainder of the contract invalid or unenforceable.
18. This contract may not be assigned by either party without the written consent of the other party.

19. This contract shall be binding upon the parties hereto and upon the successors in interest, assigns, representatives and heirs of such parties.
20. This contract shall not be amended unless in writing expressly stating that it constitutes an amendment to this contract, signed by the parties hereto.
21. The parties hereto agree that the foregoing constitutes all the agreement between the parties and in witness thereof the parties have affixed their respective signatures on the date above first note.

PASSED this 25<sup>th</sup> day of March 2026



\_\_\_\_\_  
Tazewell County Board Chairman

ATTEST:



\_\_\_\_\_  
Tazewell County Clerk

MUNICIPALITY:



\_\_\_\_\_  
Mayor or Village Board President

TAZEWELL COUNTY ANIMAL CONTROL:



\_\_\_\_\_  
Director

Annual Amount:

\$1,325.67

**COMMITTEE REPORT**

HS-26-18

Mr. Chairman and Members of the Tazewell County Board:

Your Health Services Committee has considered the following RESOLUTION and recommends that it be adopted by the Board:

-----  
**RESOLUTION**

WHEREAS, the County's Health Services Committee recommends to the County Board that it enter into an agreement with the City of East Peoria which will be entered into pursuant to Article 7, Section 10 of the Constitution of the State of Illinois of 1970; and

WHEREAS, The County agrees to provide the Animal and Rabies Control Services through the Tazewell County Animal & Rabies Control Department, its Administrator, Director, Deputies, and Agents effective January 1, 2026 for the period of one year; and

WHEREAS, the City of East Peoria shall pay the County in the sum of \$36,070.24 for the services.

THEREFORE BE IT RESOLVED that the County Board approve this agreement.

BE IT FURTHER RESOLVED that the County Clerk notifies the County Board Office, Director of Animal Control, the Mayor of East Peoria, and the Auditor of this action.

PASSED THIS 25<sup>th</sup> DAY OF MARCH, 2026.

ATTEST:

  
\_\_\_\_\_  
Tazewell County Clerk

  
\_\_\_\_\_  
Tazewell County Board Chairman

**INTERGOVERNMENTAL AGREEMENT**  
**FOR**  
**ANIMAL & RABIES CONTROL SERVICES**

THIS AGREEMENT, entered into this 1ST day of JANUARY, 2026, by and between the County of Tazewell, Illinois, a body politic and corporate (hereinafter referred to as "County") and the CITY OF EAST PEORIA, a unit of local government of the State of Illinois (hereinafter referred to as "Municipality"), this Agreement being entered into pursuant to Article 7, Section 10 of the Constitution of the State of Illinois of 1970.

In consideration of the payment by Municipality to the County of the sum of \$36,070.24, County agrees to provide the following Animal and Rabies Control services through the Tazewell County Animal & Rabies Control Department, its administrator, director, deputies, and agents as follows.

1. The County shall respond to calls and attempt to pick up animals running at large within the corporate limits of the Municipality between the hours of 8:00 a.m. and 4:00 p.m. seven (7) days a week, including weekends, but not including regularly scheduled County Holidays.
2. The County shall, on an emergency basis only, attempt to pick up animals running at large between the hours of 4:00 p.m. and 8:00 a.m. the next morning seven (7) days a week including weekends. During these times, the County has no obligations under this contract unless an emergency exists.
3. On regularly scheduled County Holidays, the County shall, on an emergency basis only, attempt to pick up dogs running at large both day and night. On regularly scheduled County Holidays, the County has no obligations under this contract unless an emergency exists.
4. For the purposes of this Agreement, an emergency shall be considered to include but not be limited to the following situations: a.) a person in immediate danger of an animal; b.) sick or injured domestic animals running at large; c.) sick or injured wild animals; d.) aggressive animals running at large; e.) animal bite reports; f.) providing necessary assistance to police, fire or EMS agencies; g.) wildlife present in the living quarters of a home/apartment/business; however removal of such wildlife from attics, walls or closed interior areas of a building of any kind is not provided by Tazewell County Animal Control; h.) animals in extreme elements without proper shelter or access to water (e.g. a dog in frigid temperature with no access to shelter or an animal left in a hot car.)
5. Emergency calls shall be placed by the CITY authorities or a citizen of the Municipality to either the Sheriff's Office (346-4141) or the Tazewell County Animal Control facility (925-3370). All calls placed by citizens, police, or governmental bodies will be answered as soon as possible during regularly scheduled working days between the hours of 8:00 a.m. and 4:00 p.m., Monday – Friday. Responses to emergency calls shall be made by the Tazewell County Animal Control Officer who is then on duty.

6. The County of Tazewell shall accept and make reasonable response to complaints of citizens concerning dogs running at large within the corporate limits of the Municipality.
7. The County may make regular and irregular patrols in the corporate limits of the Municipality one day a week at regular and irregular hours.
8. The County shall take custody and impound animals apprehended within the corporate limits of the Municipality at the Tazewell County Animal Control facility.
9. The County shall require proof of payment of Municipal reclamation fees to the Municipality by owners of animals sought to be redeemed before releasing said animal from custody.
10. The County shall provide humane treatment of animals removed from the corporate limits of the Municipality during the period of impounding.
11. The County shall make reasonable efforts to locate the owner or owners of any impounded animal providing that said animal is wearing a collar or rabies tag capable of identifying ownership. Upon identifying the owner or any such animal, an attempt will be made for immediate notification to said owner. A letter shall be mailed to the last known address of the owner notifying him of the impoundment of his animal. Said notification will give notice to the owner that the animal shall be destroyed, adopted, or transferred after the passage of seven (7) days if not reclaimed in accordance with law by the owner. An affidavit or testimony of the Administrator, or his authorized agent, who mails such notice shall be prima facie evidence of the receipt of said notice by the owner of such animal.
12. It is mutually understood and agreed that any animal apprehended from within the corporate limits of the Municipality and impounded at the Tazewell County Animal & Rabies Control Shelter, with respect to whom the owner is unknown but which unknown owner has failed to claim the animal within four (4) working days, shall be humanely dispatched or placed for adoption at the discretion of the Director of the Tazewell County Animal Control Department pursuant to the provisions of the Animal Control Act of the State of Illinois.
13. It is further understood and agreed that the consideration payable by the Municipality to the County may at the option of the Municipality be paid in equal monthly installments.
14. This Agreement shall become effective on the 1ST day of JANUARY, 2026 and shall be in full force and effect for a period of one (1) year.
15. This contract shall be governed by and interpreted in accordance with the laws of the State of Illinois. All relevant provisions of the laws of the State of Illinois applicable hereto and required to be reflected or set forth herein are incorporated by reference.
16. No waiver of any breach of this contract or any provision hereof shall constitute a waiver of any other or further breach of this contract or any provision thereof.
17. This contract is severable, and the invalidity, or unenforceability of any provision of this contract, or a part thereof, should not render the remainder of the contract invalid or unenforceable.
18. This contract may not be assigned by either party without the written consent of the other party.

19. This contract shall be binding upon the parties hereto and upon the successors in interest, assigns, representatives and heirs of such parties.
20. This contract shall not be amended unless in writing expressly stating that it constitutes an amendment to this contract, signed by the parties hereto.
21. The parties hereto agree that the foregoing constitutes all the agreement between the parties and in witness thereof the parties have affixed their respective signatures on the date above first note.

PASSED this 25<sup>th</sup> day of March 2026

  
\_\_\_\_\_  
Tazewell County Board Chairman

ATTEST:

  
\_\_\_\_\_  
Tazewell County Clerk

MUNICIPALITY:

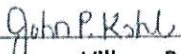
  
\_\_\_\_\_  
Mayor or Village Board President

TAZEWELL COUNTY ANIMAL CONTROL:

  
\_\_\_\_\_  
Director

Annual Amount: \$36,070.24

Triannual Amount: \$12,023.41

**COMMITTEE REPORT**

HS-26-19

Mr. Chairman and Members of the Tazewell County Board:

Your Health Services Committee has considered the following RESOLUTION and recommends that it be adopted by the Board:

-----  
**RESOLUTION**

WHEREAS, the County’s Health Services Committee recommends to the County Board that it enter into an agreement with the City of Marquette Heights which will be entered into pursuant to Article 7, Section 10 of the Constitution of the State of Illinois of 1970; and

WHEREAS, The County agrees to provide the Animal and Rabies Control Services through the Tazewell County Animal & Rabies Control Department, its Administrator, Director, Deputies, and Agents effective January 1, 2026 for the period of one year; and

WHEREAS, the City of Marquette Heights shall pay the County the sum of \$3,997.49 for the services.

THEREFORE BE IT RESOLVED that the County Board approve this agreement.

BE IT FURTHER RESOLVED that the County Clerk notifies the County Board Office, Director of Animal Control, the Marquette Heights Mayor and the Auditor of this action.

PASSED THIS 25<sup>th</sup> DAY OF MARCH, 2025.

ATTEST:

  
\_\_\_\_\_  
Tazewell County Clerk

  
\_\_\_\_\_  
Tazewell County Board Chairman

## INTERGOVERNMENTAL AGREEMENT

FOR

### ANIMAL & RABIES CONTROL SERVICES

THIS AGREEMENT, entered into this 1ST day of JANUARY, 2026, by and between the County of Tazewell, Illinois, a body politic and corporate (hereinafter referred to as "County") and the CITY OF MARQUETTE HEIGHTS, a unit of local government of the State of Illinois (hereinafter referred to as "Municipality"), this Agreement being entered into pursuant to Article 7, Section 10 of the Constitution of the State of Illinois of 1970.

In consideration of the payment by Municipality to the County of the sum of \$3,997.49, County agrees to provide the following Animal and Rabies Control services through the Tazewell County Animal & Rabies Control Department, its administrator, director, deputies, and agents as follows.

1. The County shall respond to calls and attempt to pick up animals running at large within the corporate limits of the Municipality between the hours of 8:00 a.m. and 4:00 p.m. seven (7) days a week, including weekends, but not including regularly scheduled County Holidays.
2. The County shall, on an emergency basis only, attempt to pick up animals running at large between the hours of 4:00 p.m. and 8:00 a.m. the next morning seven (7) days a week including weekends. During these times, the County has no obligations under this contract unless an emergency exists.
3. On regularly scheduled County Holidays, the County shall, on an emergency basis only, attempt to pick up dogs running at large both day and night. On regularly scheduled County Holidays, the County has no obligations under this contract unless an emergency exists.
4. For the purposes of this Agreement, an emergency shall be considered to include but not be limited to the following situations: a.) a person in immediate danger of an animal; b.) sick or injured domestic animals running at large; c.) sick or injured wild animals; d.) aggressive animals running at large; e.) animal bite reports; f.) providing necessary assistance to police, fire or EMS agencies; g.) wildlife present in the living quarters of a home/apartment/business; however removal of such wildlife from attics, walls or closed interior areas of a building of any kind is not provided by Tazewell County Animal Control; h.) animals in extreme elements without proper shelter or access to water (e.g. a dog in frigid temperature with no access to shelter or an animal left in a hot car.)
5. Emergency calls shall be placed by the CITY authorities or a citizen of the Municipality to either the Sheriff's Office (346-4141) or the Tazewell County Animal Control facility (925-3370). All calls placed by citizens, police, or governmental bodies will be answered as soon as possible during regularly scheduled working days between the hours of 8:00 a.m. and 4:00 p.m., Monday – Friday. Responses to emergency calls shall be made by the Tazewell County Animal Control Officer who is then on duty.

6. The County of Tazewell shall accept and make reasonable response to complaints of citizens concerning dogs running at large within the corporate limits of the Municipality.
7. The County may make regular and irregular patrols in the corporate limits of the Municipality one day a week at regular and irregular hours.
8. The County shall take custody and impound animals apprehended within the corporate limits of the Municipality at the Tazewell County Animal Control facility.
9. The County shall require proof of payment of Municipal reclamation fees to the Municipality by owners of animals sought to be redeemed before releasing said animal from custody.
10. The County shall provide humane treatment of animals removed from the corporate limits of the Municipality during the period of impounding.
11. The County shall make reasonable efforts to locate the owner or owners of any impounded animal providing that said animal is wearing a collar or rabies tag capable of identifying ownership. Upon identifying the owner or any such animal, an attempt will be made for immediate notification to said owner. A letter shall be mailed to the last known address of the owner notifying him of the impoundment of his animal. Said notification will give notice to the owner that the animal shall be destroyed, adopted, or transferred after the passage of seven (7) days if not reclaimed in accordance with law by the owner. An affidavit or testimony of the Administrator, or his authorized agent, who mails such notice shall be prima facie evidence of the receipt of said notice by the owner of such animal.
12. It is mutually understood and agreed that any animal apprehended from within the corporate limits of the Municipality and impounded at the Tazewell County Animal & Rabies Control Shelter, with respect to whom the owner is unknown but which unknown owner has failed to claim the animal within four (4) working days, shall be humanely dispatched or placed for adoption at the discretion of the Director of the Tazewell County Animal Control Department pursuant to the provisions of the Animal Control Act of the State of Illinois.
13. It is further understood and agreed that the consideration payable by the Municipality to the County may at the option of the Municipality be paid in equal monthly installments.
14. This Agreement shall become effective on the 1ST day of JANUARY, 2026 and shall be in full force and effect for a period of one (1) year.
15. This contract shall be governed by and interpreted in accordance with the laws of the State of Illinois. All relevant provisions of the laws of the State of Illinois applicable hereto and required to be reflected or set forth herein are incorporated by reference.
16. No waiver of any breach of this contract or any provision hereof shall constitute a waiver of any other or further breach of this contract or any provision thereof.
17. This contract is severable, and the invalidity, or unenforceability of any provision of this contract, or a part thereof, should not render the remainder of the contract invalid or unenforceable.
18. This contract may not be assigned by either party without the written consent of the other party.

19. This contract shall be binding upon the parties hereto and upon the successors in interest, assigns, representatives and heirs of such parties.
20. This contract shall not be amended unless in writing expressly stating that it constitutes an amendment to this contract, signed by the parties hereto.
21. The parties hereto agree that the foregoing constitutes all the agreement between the parties and in witness thereof the parties have affixed their respective signatures on the date above first note.

PASSED this 25<sup>th</sup> day of March 2026

  
\_\_\_\_\_  
Tazewell County Board Chairman

ATTEST:

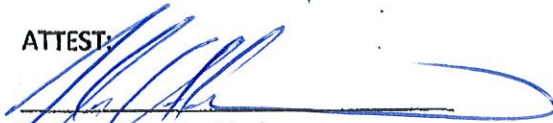
  
\_\_\_\_\_  
Tazewell County Clerk

MUNICIPALITY:

  
\_\_\_\_\_  
Mayor or Village Board President

TAZEWELL COUNTY ANIMAL CONTROL:

  
\_\_\_\_\_  
Director

Annual Amount:        \$3,997.49

Triannual Amount:    \$1,332.49

**COMMITTEE REPORT**

Mr. Chairman and Members of the Tazewell County Board:

Your Health Services Committee has considered the following RESOLUTION and recommends that it be adopted by the Board:

-----  
**RESOLUTION**

WHEREAS, the County's Health Services Committee recommends to the County Board that it enter into an agreement with the Village of Morton which will be entered into pursuant to Article 7, Section 10 of the Constitution of the State of Illinois of 1970; and

WHEREAS, the County agrees to provide the Animal and Rabies Control Services through the Tazewell County Animal & Rabies Control Department, its Administrator, Director, Deputies, and Agents effective January 1, 2026 for the period of one year; and

WHEREAS, the Village of Morton shall pay the County the sum of \$15,177.32 for the services.

THEREFORE BE IT RESOLVED that the County Board approve this agreement.

BE IT FURTHER RESOLVED that the County Clerk notifies the County Board Office, Director of Animal Control, the Mayor of Morton, and the Auditor of this action.

PASSED THIS 25<sup>th</sup> DAY OF MARCH, 2025.

ATTEST:

  
\_\_\_\_\_  
Tazewell County Clerk

  
\_\_\_\_\_  
Tazewell County Board Chairman

**INTERGOVERNMENTAL AGREEMENT**  
**FOR**  
**ANIMAL & RABIES CONTROL SERVICES**

THIS AGREEMENT, entered into this 1ST day of JANUARY, 2026, by and between the County of Tazewell, Illinois, a body politic and corporate (hereinafter referred to as "County") and the VILLAGE OF MORTON, a unit of local government of the State of Illinois (hereinafter referred to as "Municipality"), this Agreement being entered into pursuant to Article 7, Section 10 of the Constitution of the State of Illinois of 1970.

In consideration of the payment by Municipality to the County of the sum of \$15,177.32, County agrees to provide the following Animal and Rabies Control services through the Tazewell County Animal & Rabies Control Department, its administrator, director, deputies, and agents as follows.

1. The County shall respond to calls and attempt to pick up animals running at large within the corporate limits of the Municipality between the hours of 8:00 a.m. and 4:00 p.m. seven (7) days a week, including weekends, but not including regularly scheduled County Holidays.
2. The County shall, on an emergency basis only, attempt to pick up animals running at large between the hours of 4:00 p.m. and 8:00 a.m. the next morning seven (7) days a week including weekends. During these times, the County has no obligations under this contract unless an emergency exists.
3. On regularly scheduled County Holidays, the County shall, on an emergency basis only, attempt to pick up dogs running at large both day and night. On regularly scheduled County Holidays, the County has no obligations under this contract unless an emergency exists.
4. For the purposes of this Agreement, an emergency shall be considered to include but not be limited to the following situations: a.) a person in immediate danger of an animal; b.) sick or injured domestic animals running at large; c.) sick or injured wild animals; d.) aggressive animals running at large; e.) animal bite reports; f.) providing necessary assistance to police, fire or EMS agencies; g.) wildlife present in the living quarters of a home/apartment/business; however removal of such wildlife from attics, walls or closed interior areas of a building of any kind is not provided by Tazewell County Animal Control; h.) animals in extreme elements without proper shelter or access to water (e.g. a dog in frigid temperature with no access to shelter or an animal left in a hot car.)
5. Emergency calls shall be placed by the VILLAGE authorities or a citizen of the Municipality to either the Sheriff's Office (346-4141) or the Tazewell County Animal Control facility (925-3370). All calls placed by citizens, police, or governmental bodies will be answered as soon as possible during regularly scheduled working days between the hours of 8:00 a.m. and 4:00 p.m., Monday – Friday. Responses to emergency calls shall be made by the Tazewell County Animal Control Officer who is then on duty.

6. The County of Tazewell shall accept and make reasonable response to complaints of citizens concerning dogs running at large within the corporate limits of the Municipality.
7. The County may make regular and irregular patrols in the corporate limits of the Municipality one day a week at regular and irregular hours.
8. The County shall take custody and impound animals apprehended within the corporate limits of the Municipality at the Tazewell County Animal Control facility.
9. The County shall require proof of payment of Municipal reclamation fees to the Municipality by owners of animals sought to be redeemed before releasing said animal from custody.
10. The County shall provide humane treatment of animals removed from the corporate limits of the Municipality during the period of impounding.
11. For each animal impounded from within the municipality, the County shall provide a clear digital image of the animal to an agreed representative of the village, along with any relevant information about the animal, as soon as practicable. The Village shall provide notice to the County of a single agreed representative for notification purposes.
12. The County shall make reasonable efforts to locate the owner or owners of any impounded animal providing that said animal is wearing a collar or rabies tag capable of identifying ownership. Upon identifying the owner or any such animal, an attempt will be made for immediate notification to said owner. A letter shall be mailed to the last known address of the owner notifying him of the impoundment of his animal. Said notification will give notice to the owner that the animal shall be destroyed, adopted, or transferred after the passage of seven (7) days if not reclaimed in accordance with law by the owner. An affidavit or testimony of the Administrator, or his authorized agent, who mails such notice shall be prima facie evidence of the receipt of said notice by the owner of such animal.
13. It is mutually understood and agreed that any animal apprehended from within the corporate limits of the Municipality and impounded at the Tazewell County Animal & Rabies Control Shelter, with respect to whom the owner is unknown but which unknown owner has failed to claim the animal within four (4) working days, shall be humanely dispatched or placed for adoption at the discretion of the Director of the Tazewell County Animal Control Department pursuant to the provisions of the Animal Control Act of the State of Illinois.
14. It is further understood and agreed that the consideration payable by the Municipality to the County may at the option of the Municipality be paid in equal monthly installments.
15. This Agreement shall become effective on the 1ST day of JANUARY, 2026 and shall be in full force and effect for a period of 1 year.
16. This contract shall be governed by and interpreted in accordance with the laws of the State of Illinois. All relevant provisions of the laws of the State of Illinois applicable hereto and required to be reflected or set forth herein are incorporated by reference.
17. No waiver of any breach of this contract or any provision hereof shall constitute a waiver of any other or further breach of this contract or any provision thereof.

18. This contract is severable, and the invalidity, or unenforceability of any provision of this contract, or a part thereof, should not render the remainder of the contract invalid or unenforceable.
19. This contract may not be assigned by either party without the written consent of the other party.
20. This contract shall be binding upon the parties hereto and upon the successors in interest, assigns, representatives and heirs of such parties.
21. This contract shall not be amended unless in writing expressly stating that it constitutes an amendment to this contract, signed by the parties hereto.
22. The parties hereto agree that the foregoing constitutes all the agreement between the parties and in witness thereof the parties have affixed their respective signatures on the date above first note.

PASSED this 25<sup>th</sup> day of March 2026.

  
\_\_\_\_\_  
Tazewell County Board Chairman

ATTEST:  
  
\_\_\_\_\_  
Tazewell County Clerk

MUNICIPALITY:

  
\_\_\_\_\_  
Mayor or Village Board President

TAZEWELL COUNTY ANIMAL CONTROL:

  
\_\_\_\_\_  
Director

Annual Amount: \$15,177.32

Triannual Amount: \$5,059.10

**COMMITTEE REPORT**

Mr. Chairman and Members of the Tazewell County Board:

Your Health Services Committee has considered the following RESOLUTION and recommends that it be adopted by the Board:

-----  
**RESOLUTION**

WHEREAS, the County's Health Services Committee recommends to the County Board that it enter into an agreement with the Village of Green Valley which will be entered into pursuant to Article 7, Section 10 of the Constitution of the State of Illinois of 1970; and

WHEREAS, the County agrees to provide the Animal and Rabies Control Services through the Tazewell County Animal & Rabies Control Department, its Administrator, Director, Deputies, and Agents effective January 1, 2026 for the period of one year; and

WHEREAS, the Village of Green Valley shall pay the County the sum of \$999.62 for the services.

THEREFORE BE IT RESOLVED that the County Board approve this agreement.

BE IT FURTHER RESOLVED that the County Clerk notifies the County Board Office, Director of Animal Control, the Green Valley Village President and the Auditor of this action.

PASSED THIS 25<sup>th</sup> DAY OF MARCH, 2026.

ATTEST:

  
\_\_\_\_\_  
Tazewell County Clerk

  
\_\_\_\_\_  
Tazewell County Board Chairman

**INTERGOVERNMENTAL AGREEMENT**

**FOR**

**ANIMAL & RABIES CONTROL SERVICES**

THIS AGREEMENT, entered into this 1ST day of JANUARY, 2026, by and between the County of Tazewell, Illinois, a body politic and corporate (hereinafter referred to as "County") and the VILLAGE OF GREEN VALLEY, a unit of local government of the State of Illinois (hereinafter referred to as "Municipality"), this Agreement being entered into pursuant to Article 7, Section 10 of the Constitution of the State of Illinois of 1970.

In consideration of the payment by Municipality to the County of the sum of \$999.62, County agrees to provide the following Animal and Rabies Control services through the Tazewell County Animal & Rabies Control Department, its administrator, director, deputies, and agents as follows.

1. The County shall respond to calls and attempt to pick up animals running at large within the corporate limits of the Municipality between the hours of 8:00 a.m. and 4:00 p.m. seven (7) days a week, including weekends, but not including regularly scheduled County Holidays.
2. The County shall, on an emergency basis only, attempt to pick up animals running at large between the hours of 4:00 p.m. and 8:00 a.m. the next morning seven (7) days a week including weekends. During these times, the County has no obligations under this contract unless an emergency exists.
3. On regularly scheduled County Holidays, the County shall, on an emergency basis only, attempt to pick up dogs running at large both day and night. On regularly scheduled County Holidays, the County has no obligations under this contract unless an emergency exists.
4. For the purposes of this Agreement, an emergency shall be considered to include but not be limited to the following situations: a.) a person in immediate danger of an animal; b.) sick or injured domestic animals running at large; c.) sick or injured wild animals; d.) aggressive animals running at large; e.) animal bite reports; f.) providing necessary assistance to police, fire or EMS agencies; g.) wildlife present in the living quarters of a home/apartment/business; however removal of such wildlife from attics, walls or closed interior areas of a building of any kind is not provided by Tazewell County Animal Control; h.) animals in extreme elements without proper shelter or access to water (e.g. a dog in frigid temperature with no access to shelter or an animal left in a hot car.)
5. Emergency calls shall be placed by the VILLAGE authorities or a citizen of the Municipality to either the Sheriff's Office (346-4141) or the Tazewell County Animal Control facility (925-3370). All calls placed by citizens, police, or governmental bodies will be answered as soon as possible during regularly scheduled working days between the hours of 8:00 a.m. and 4:00 p.m., Monday – Friday. Responses to emergency calls shall be made by the Tazewell County Animal Control Officer who is then on duty.

6. The County of Tazewell shall accept and make reasonable response to complaints of citizens concerning dogs running at large within the corporate limits of the Municipality.
7. The County may make regular and irregular patrols in the corporate limits of the Municipality one day a week at regular and irregular hours.
8. The County shall take custody and impound animals apprehended within the corporate limits of the Municipality at the Tazewell County Animal Control facility.
9. The County shall require proof of payment of Municipal reclamation fees to the Municipality by owners of animals sought to be redeemed before releasing said animal from custody.
10. The County shall provide humane treatment of animals removed from the corporate limits of the Municipality during the period of impounding.
11. The County shall make reasonable efforts to locate the owner or owners of any impounded animal providing that said animal is wearing a collar or rabies tag capable of identifying ownership. Upon identifying the owner or any such animal, an attempt will be made for immediate notification to said owner. A letter shall be mailed to the last known address of the owner notifying him of the impoundment of his animal. Said notification will give notice to the owner that the animal shall be destroyed, adopted, or transferred after the passage of seven (7) days if not reclaimed in accordance with law by the owner. An affidavit or testimony of the Administrator, or his authorized agent, who mails such notice shall be prima facie evidence of the receipt of said notice by the owner of such animal.
12. It is mutually understood and agreed that any animal apprehended from within the corporate limits of the Municipality and impounded at the Tazewell County Animal & Rabies Control Shelter, with respect to whom the owner is unknown but which unknown owner has failed to claim the animal within four (4) working days, shall be humanely dispatched or placed for adoption at the discretion of the Director of the Tazewell County Animal Control Department pursuant to the provisions of the Animal Control Act of the State of Illinois.
13. It is further understood and agreed that the consideration payable by the Municipality to the County may at the option of the Municipality be paid in equal monthly installments.
14. This Agreement shall become effective on the 1ST day of JANUARY, 2026 and shall be in full force and effect for a period of one (1) year.
15. This contract shall be governed by and interpreted in accordance with the laws of the State of Illinois. All relevant provisions of the laws of the State of Illinois applicable hereto and required to be reflected or set forth herein are incorporated by reference.
16. No waiver of any breach of this contract or any provision hereof shall constitute a waiver of any other or further breach of this contract or any provision thereof.
17. This contract is severable, and the invalidity, or unenforceability of any provision of this contract, or a part thereof, should not render the remainder of the contract invalid or unenforceable.
18. This contract may not be assigned by either party without the written consent of the other party.

19. This contract shall be binding upon the parties hereto and upon the successors in interest, assigns, representatives and heirs of such parties.
20. This contract shall not be amended unless in writing expressly stating that it constitutes an amendment to this contract, signed by the parties hereto.
21. The parties hereto agree that the foregoing constitutes all the agreement between the parties and in witness thereof the parties have affixed their respective signatures on the date above first note.

PASSED this 25<sup>th</sup> day of March 2026.

  
\_\_\_\_\_  
Tazewell County Board Chairman

ATTEST:  
  
\_\_\_\_\_  
Tazewell County Clerk

MUNICIPALITY:

  
\_\_\_\_\_  
Mayor or Village Board President

TAZEWELL COUNTY ANIMAL CONTROL:

  
\_\_\_\_\_  
Director

Annual Amount: \$999.62

COMMITTEE REPORT

Mr. Chairman and Members of Tazewell County Board:

Your Transportation Committee has considered the attached RESOLUTION and recommends that it be adopted by the Board.



RESOLUTION

**THEREFORE BE IT RESOLVED**, that the County Clerk notify the County Board Chairman, Chairman of the Transportation Committee and County Engineer of this action as well as submit four (4) certified signed originals of the approved resolution to the Illinois Department of Transportation as notification of this action.

ADOPTED this 25th day of March, 2026

ATTEST:

  
\_\_\_\_\_  
County Clerk

  
\_\_\_\_\_  
County Board Chairman

**LOCAL PUBLIC AGENCY**

Local Public Agency		County	Section Number
Tazewell County		Tazewell	25-00057-07-RS
Fund Type	ITEP, SRTS, HSIP Number(s)	MPO Name	MPO TIP Number
LPF	N/A	N/A	TZ-26-01

**Construction**

State Job Number	Project Number
C-94-042-26	

- Local Let/Day Labor   
  Construction on State Letting   
  Construction Engineering   
  Utilities   
  Railroad Work

**LOCATION**

Local Street/Road Name	Key Route	Length	Stationing	
			From	To
Broadway RD (CH 19)	FAS 1467	2.83 MI	02.53	05.36

Location Termini

Springfield RD (CH 1) to I-155 Interchange

Current Jurisdiction	Existing Structure Number(s)	
Tazewell County	N/A	<input type="button" value="Remove"/>

**PROJECT DESCRIPTION**

Resurfacing Broadway Road

Local Public Agency	Section Number	State Job Number	Project Number
Tazewell County	25-00057-07-RS	C9404226	

This Agreement is made and entered into between the above local public agency, hereinafter referred to as the "LPA" and the State of Illinois, acting by and through its Department of Transportation, hereinafter referred to as the "STATE". The STATE and LPA jointly proposes to improve the designated location as described in the Location and Project Description sections of this agreement. The improvement shall be constructed in accordance with plans prepared by, or on behalf of the LPA and approved by the STATE using the STATE's policies and procedures approved and/or required by the Federal Highway Administration, hereby referred to as "FHWA".

## I. GENERAL

- 1.1 Availability of Appropriation; Sufficiency of Funds. This Agreement is contingent upon and subject to the availability of sufficient funds. The STATE may terminate or suspend this Agreement, in whole or in part, without penalty or further payment being required, if (i) sufficient funds for this Agreement have not been appropriated or otherwise made available to the LPA by the STATE or the federal funding source, (ii) the Governor or STATE reserves funds, or (iii) the Governor or STATE determines that funds will not or may not be available for payment. The STATE shall provide notice, in writing, to LPA of any such funding failure and its election to terminate or suspend this Agreement as soon as practicable. Any suspension or termination pursuant to this Section will be effective upon the date of the written notice unless otherwise indicated.
- 1.2 Domestic Steel Requirement. Construction of the project will utilize domestic steel as required by Section 106.01 of the current edition of the Standard Specifications for Road and Bridge Construction and federal Build America-Buy America provisions.
- 1.3 Federal Authorization. That this Agreement and the covenants contained herein shall become null and void in the event that the FHWA does not approve the proposed improvement for Federal-aid participation within one (1) year of the date of execution of this agreement.
- 1.4 Severability. If any provision of this Agreement is declared invalid, its other provisions shall not be affected thereby.
- 1.5 Termination. This Agreement may be terminated, in whole or in part, by either Party for any or no reason upon thirty (30) calendar days' prior written notice to the other Party. If terminated by the STATE, the STATE must include the reasons for such termination, the effective date, and, in the case of a partial termination, the portion to be terminated. If the STATE determines in the case of a partial termination that the reduced or modified portion of the funding award will not accomplish the purposes for which the funding award was made, the STATE may terminate the Agreement in its entirety.

This Agreement may be terminated, in whole or in part, by the STATE without advance notice:

- a. Pursuant to a funding failure as provided under Article 1.1.
- b. If LPA fails to comply with the terms and conditions of this funding award, application or proposal, including any applicable rules or regulations, or has made a false representation in connection with the receipt of this or any award.

## II. REQUIRED CERTIFICATIONS

By execution of this Agreement and the LPA's obligations and services hereunder are hereby made and must be performed in compliance with all applicable federal and State laws, including, without limitation, federal regulations, State administrative rules and any and all license requirements or professional certification provisions.

- 2.1 Uniform Administrative Requirements, Cost Principles, and Audit Requirements for Federal Awards (2 CFR Part 200). The LPA certifies that it shall adhere to the applicable Uniform Administrative Requirements, Cost Principles, and Audit Requirements, which are published in Title 2, Part 200 of the Code of Federal Regulations, and are incorporated herein by reference.
- 2.2 Compliance with Registration Requirements. LPA certifies that it: (i) is registered with the federal SAM system; (ii) is in good standing with the Illinois Secretary of State, if applicable; (iii) have a valid DUNS Number; (iv) have a valid UEI, if applicable. It is LPA's responsibility to remain current with these registrations and requirements.
- 2.3 Bribery. The LPA certifies to the best of its knowledge that its officials have not been convicted of bribery or attempting to bribe an officer or employee of the state of Illinois, nor made an admission of guilt of such conduct which is a matter of record (30 ILCS 500/50-5).
- 2.4 Bid Rigging. LPA certifies that it has not been barred from contracting with a unit of state or local government as a result of a violation of Paragraph 33E-3 or 33E-4 of the Criminal Code of 1961 (720 ILCS 5/33E-3 or 720 ILCS 5/33E-4, respectively).
- 2.5 Debt to State. LPA certifies that neither it, nor its affiliate(s), is/are barred from receiving an Award because the LPA, or its affiliate(s), is/are delinquent in the payment of any debt to the STATE, unless the LPA, or its affiliate(s), has/have entered into a deferred payment plan to pay off the debt, and STATE acknowledges the LPA may declare the Agreement void if the certification is false (30 ILCS 500/50-11).
- 2.6 Debarment. The LPA certifies to the best of its knowledge and belief that its officials:
  - a. are not presently debarred, suspended, proposed for debarment, declared ineligible or voluntarily excluded from covered transactions by any Federal department or agency;
  - b. have not within a three-year period preceding this agreement been convicted of or had a civil judgment rendered against them for commission of fraud or a criminal offense in connection with obtaining, attempting to obtain, or performing a public (Federal, State or local) transaction or contract under a public transaction; violation of Federal or State anti-trust statutes or

Local Public Agency	Section Number	State Job Number	Project Number
Tazewell County	25-00057-07-RS	C9404226	

commission of embezzlement, theft, forgery, bribery, falsification or destruction of records, making false statements receiving stolen property;

c. are not presently indicated for or otherwise criminally or civilly charged by a governmental entity (Federal, State, Local) with commission of any of the offenses enumerated in item (b) of this certification; and

d. have not within a three-year period preceding the agreement had one or more public transactions (Federal, State, Local) terminated for cause or default.

- 2.7 Construction of Fixed Works. The LPA certifies that all Programs for the construction of fixed works which are financed in whole or in part with funds provided by this Agreement shall be subject to the Prevailing Wage Act (820 ILCS 130/0.01 *et seq.*) unless the provisions of that Act exempt its application. In the construction of the Program, the LPA shall comply with the requirements of the Prevailing Wage Act including, but not limited to, inserting into all contracts for such construction a stipulation to the effect that not less than the prevailing rate of wages as applicable to the Program shall be paid to all laborers, workers, and mechanics performing work under the Award and requiring all bonds of contractors to include a provision as will guarantee the faithful performance of such prevailing wage clause as provided by contract.
- 2.8 Criminal Convictions. The LPA certifies that neither it nor any managerial agent of LPA has been convicted of a felony under the Sarbanes-Oxley Act of 2002, nor a Class 3 or Class 2 felony under Illinois Securities Law of 1953, or that at least five (5) years have passed since the date of the conviction. The LPA further certifies that it is not barred from receiving an funding award under 30 ILCS 500/50-10.5 and acknowledges that STATE shall declare the Agreement void if this certification is false (30 ILCS 500/50-10.5).
- 2.9 Improper Influence. The LPA certifies that no funds have been paid or will be paid by or on behalf of the LPA to any person for influencing or attempting to influence an officer or employee of any government agency, a member of Congress or Illinois General Assembly, an officer or employee of Congress or Illinois General Assembly, or an employee of a member of Congress or Illinois General Assembly in connection with the awarding of any agreement, the making of any grant, the making of any loan, the entering into of any cooperative agreement, or the extension, continuation, renewal, amendment or modification of any agreement, grant, loan or cooperative agreement. 31 USC 1352. Additionally, the LPA certifies that it has filed the required certification under the Byrd Anti-Lobbying Amendment (31 USC 1352), if applicable.
- 2.10 Telecom Prohibition. The LPA certifies that it will comply with Section 889 of the FY 2019 National Defense Authorization Act (NDAA) that prohibits the use of telecommunications or video surveillance equipment or services produced or provided by the following companies: Dahua Technology Company, Hangzhou Hikvision Digital Technology Company, Huawei Technologies Company, Hytera Communications Corporation, and ZTE Corporation. Covered equipment and services cannot be used as substantial or essential component or any system, or as critical technology as part of any system.
- 2.11 Personal Conflict of Interest - (50 ILCS 105/3, 65 ILCS 5/3.1-55-10, 65 ILCS 5/4-8-6) The LPA certifies that it shall maintain a written code or standard of conduct which shall govern the performance of its employees, officers, board members, or agents engaged in the award and administration of contracts supported by state or federal funds. Such code shall provide that no employee, officer, board member or agent of the LPA may participate in the selection, award, or administration of a contract supported by state or federal funds if a conflict of interest, real or apparent would be involved. Such a conflict would arise when any of the parties set forth below has a financial or other interest in the firm selected for award:
- the employee, officer, board member, or agent;
  - any member of his or her immediate family;
  - his or her partner; or
  - an organization which employs, or is about to employ, any of the above.

The conflict of interest restriction for former employees, officers, board members and agents shall apply for one year.

The code shall also provide that LPA's employees, officers, board members, or agents shall neither solicit nor accept gratuities, favors or anything of monetary value from contractors, potential contractors, or parties to subcontracts. The STATE may waive the prohibition contained in this subsection, provided that any such present employee, officer, board member, or agent shall not participate in any action by the LPA relating to such contract, subcontract, or arrangement. The code shall also prohibit the officers, employees, board members, or agents of the LPA from using their positions for a purpose that constitutes or presents the appearance of personal or organizational conflict of interest or personal gain.

- 2.12 Organizational Conflict of Interest - The LPA certifies that it will also prevent any real or apparent organizational conflict of interest. An organizational conflict of interest exists when the nature of the work to be performed under a proposed third party contract or subcontract may, without some restriction on future activities, result in an unfair competitive advantage to the third party contractor or LPA or impair the objectivity in performing the contract work.
- 2.13 Accounting System. The LPA certifies that it has an accounting system that provides accurate, current, and complete disclosure of all financial transactions related to each state and federally funded program. Accounting records must contain information

Local Public Agency	Section Number	State Job Number	Project Number
Tazewell County	25-00057-07-RS	C9404226	

pertaining to state and federal pass-through awards, authorizations, obligations, unobligated balances, assets, outlays, and income. To comply with 2 CFR 200.305(b)(7)(i), the LPA shall use reasonable efforts to ensure that funding streams are delineated within LPA's accounting system. See 2 CFR 200.302.

### III. AUDIT AND RECORD RETENTION

- 3.1 Single Audits: The LPA shall be subject to the audit requirements contained in the Single Audit Act Amendments of 1996 (31 USC 7501-7507) and Subpart F of 2 CFR Part 200.

If, during its fiscal year, LPA expends \$750,000 or more in Federal Awards (direct federal and federal pass-through awards combined), LPA must have a single audit or program-specific audit conducted for that year as required by 2 CFR 200.501 and other applicable sections of Subpart F of 2 CFR Part 200. A copy of the audit report must be submitted to the STATE (IDOT's Financial Review & Investigations Section, Room 126, 2300 South Dirksen Parkway, Springfield, Illinois, 62764) within 30 days after the completion of the audit, but no later than one year after the end of the LPA's fiscal year.

Assistance Listing number (formally known as the Catalog of Federal Domestic Assistance (CFDA) number) for all highway planning and construction activities is **20.205**.

Federal funds utilized for construction activities on projects let and awarded by the STATE (federal amounts shown as "Participating Construction" on Schedule 2) are not included in a LPA's calculation of federal funds expended by the LPA for Single Audit purposes.

- 3.2 STATE Audits: The STATE may, at its sole discretion and at its own expense, perform a final audit of the Project (30 ILCS 5, the Illinois State Auditing Act). Such audit may be used for settlement of the Project expenses and for Project closeout purposes. The LPA agrees to implement any audit findings contained in the STATE's authorized inspection or review, final audit, the STATE's independent audit, or as a result of any duly authorized inspection or review.
- 3.3 Record Retention. The LPA shall maintain for three (3) years from the date of final project closeout by the STATE, adequate books, records, and supporting documents to verify the amounts, recipient, and uses of all disbursements of funds passing in conjunction with this contract. adequate to comply with 2 CFR 200.334. If any litigation, claim or audit is started before the expiration of the retention period, the records must be retained until all litigation, claims or audit exceptions involving the records have been resolved and final action taken.
- 3.4 Accessibility of Records. The LPA shall permit, and shall require its contractors and auditors to permit, the STATE, and any authorized agent of the STATE, to inspect all work, materials, payrolls, audit working papers, and other data and records pertaining to the Project; and to audit the books, records, and accounts of the LPA with regard to the Project. The LPA in compliance with 2 CFR 200.337 shall make books, records, related papers, supporting documentation and personnel relevant to this Agreement available to authorized STATE representatives, the Illinois Auditor General, Illinois Attorney General, any Executive Inspector General, the STATE's Inspector General, federal authorities, any person identified in 2 CFR 200.337, and any other person as may be authorized by the STATE (including auditors), by the state of Illinois or by federal statute. The LPA shall cooperate fully in any such audit or inquiry.
- 3.5 Failure to maintain the books and records. Failure to maintain the books, records and supporting documents required by this section shall establish presumption in favor of the STATE for recovery of any funds paid by the STATE under the terms of this contract.

### IV. LPA FISCAL RESPONSIBILITIES

- 4.1 To provide all initial funding and payment for construction engineering, utility, and railroad work
- 4.2 LPA Appropriation Requirement. By execution of this Agreement the LPA attests that sufficient moneys have been appropriated or reserved by resolution or ordinance to fund the LPA share of project costs. A copy of the authorizing resolution or ordinance is attached as Schedule 5.
- 4.3 Reimbursement Requests: For reimbursement requests the LPA will submit supporting documentation with each invoice. Supporting documentation is defined as verification of payment, certified time sheets or summaries, vendor invoices, vendor receipts, cost plus fix fee invoice, progress report, personnel and direct cost summaries, and other documentation supporting the requested reimbursement amount (Form BLR 05621 should be used for consultant invoicing purposes). LPA invoice requests to the STATE will be submitted with sequential invoice numbers by project.
- 4.4 Financial Integrity Review and Evaluation (FIRE) program: LPA's and the STATE must justify continued federal funding on inactive projects. 23 CFR 630.106(a)(5) defines an inactive project as a project which no expenditures have been charged against Federal funds for the past twelve (12) months. To keep projects active, invoicing must occur a minimum of one time within any given twelve (12) month period. However, to ensure adequate processing time, the first invoice shall be submitted to the STATE within six (6) months of the federal authorization date. Subsequent invoices will be submitted in intervals not to exceed six (6) months.
- 4.5 Final Invoice: The LPA will submit to the STATE a complete and detailed final invoice with applicable supporting documentation of all incurred costs, less previous payments, no later than twelve (12) months from the date of completion of work or from the date of the previous invoice, whichever occurs first. If a final invoice is not received within this time frame, the most recent invoice

Local Public Agency	Section Number	State Job Number	Project Number
Tazewell County	25-00057-07-RS	C9404226	

may be considered the final invoice and the obligation of the funds closed. Form BLR 05613 (Engineering Payment Record) is required to be submitted with the final invoice for engineering projects.

- 4.6 **Project Closeout:** The **LPA** shall provide the final report to the appropriate **STATE** district office within twelve (12) months of the physical completion date of the project so that the report may be audited and approved for payment. If the deadline cannot be met, a written explanation must be provided to the district prior to the end of the twelve (12) months documenting the reason and the new anticipated date of completion. If the extended deadline is not met, this process must be repeated until the project is closed. Failure to follow this process may result in the immediate close-out of the project and loss of further funding.
- 4.7 **Project End Date:** The period of performance (end date) for state and federal obligation purposes is five (5) years for projects under \$1,000,000 or seven (7) years for projects over \$1,000,000 from the execution date of the agreement. Requests for time extensions and joint agreement amendments must be received and approved prior to expiration of the project end date. Failure to extend the end date may result in the immediate close-out of the project and loss of further funding.

## V. THE LPA AGREES

- 5.1 To acquire in its name, or in the name of the **STATE** if on the **STATE** highway system, all right-of-way necessary for this project in accordance with the requirements of Titles II and III of the Uniform Relocation Assistance and Real Property Acquisition Policies Act of 1970, and established State policies and procedures. Prior to advertising for bids, the **LPA** shall certify to the **STATE** that all requirements of Titles II and III of said Uniform Act have been satisfied. The disposition of encroachments, if any, will be cooperatively determined by representatives of the **LPA**, the **STATE**, and the **FHWA** if required.
- 5.2 To provide for all utility adjustments and to regulate the use of the right-of-way of this improvement by utilities, public and private, in accordance with the current Utility Accommodation Policy for Local Public Agency Highway and Street Systems.
- 5.3 To provide on-site engineering supervision and inspection during construction of the proposed improvement.
- 5.4 To retain jurisdiction of the completed improvement unless specified otherwise by schedule (schedule should be accompanied by a location map). If the improvement location is currently under road district jurisdiction, a jurisdictional schedule is required.
- 5.5 To maintain or cause to be maintained the completed improvement (or that portion within its jurisdiction as established by schedule) in a manner satisfactory to the **STATE** and the **FHWA**.
- 5.6 To provide if required, for the improvement of any railroad-highway grade crossing and rail crossing protection within the limits of the proposed improvement.
- 5.7 To regulate parking and traffic in accordance with the approved project report.
- 5.8 To regulate encroachments on public rights-of-way in accordance with current Illinois Compiled Statutes.
- 5.9 To regulate the discharge of sanitary sewage into any storm water drainage system constructed with this improvement in accordance with the current Illinois Compiled Statutes.
- 5.10 For contracts awarded by the **LPA**, the **LPA** shall not discriminate on the basis of race, color, national origin or sex in the award and performance of any USDOT - assisted contract or in the administration of its DBE program or the requirements of 49 CFR part 26. The **LPA** shall take all necessary and reasonable steps under 49 CFR part 26 to ensure nondiscrimination in the award and administration of USDOT - assisted contracts. The **LPA's** DBE program, as required by 49 CFR part 26 and as approved by USDOT, is incorporated by reference in this agreement. Upon notification to the recipient of its failure to carry out its approved program, the **STATE** may impose sanctions as provided for under Part 26 and may, in appropriate cases, refer the matter for enforcement under 18 U.S. C 1001 and/or the Program Fraud Civil Remedies Act of 1986 (31 U.S.C 3801 et seq.). In the absence of a USDOT - approved **LPA** DBE Program or on **STATE** awarded contracts, this agreement shall be administered under the provisions of the **STATE'S** USDOT approved Disadvantaged Business Enterprise Program.
- 5.12 That execution of this agreement constitutes the **LPA's** concurrence in the award of the construction contract to the responsible low bidder as determined by the **STATE**.

## VI. THE STATE AGREES

- 6.1 To provide such guidance, assistance, and supervision to monitor and perform audits to the extent necessary to assure validity of the **LPA's** certification of compliance with Title II and III Requirements.
- 6.2 To receive bids for construction of the proposed improvement when the plans have been approved by the **STATE** (and **FHWA**, if required) and to award a contract for construction of the proposed improvement after receipt of a satisfactory bid.
- 6.3 To provide all initial funding and payments to the contractor for construction work let by the **STATE**. The **LPA** will be invoiced for their share of contract costs per the method of payment selected under Method of Financing based on the Division of Costs shown on Schedule 2.

Local Public Agency	Section Number	State Job Number	Project Number
Tazewell County	25-00057-07-RS	C9404226	

6.4 For agreements with federal and/or state funds in local let/day labor construction, construction engineering, utility work and/or railroad work:

- a. To reimburse the **LPA** for federal and/or state share on the basis of periodic billings, provided said billings contain sufficient cost information and show evidence of payments by the **LPA**;
- b. To provide independent assurance sampling and furnish off-site material inspection and testing at sources normally visited by **STATE** inspectors for steel, cement, aggregate, structural steel, and other materials customarily tested by the **STATE**.

**SCHEDULES**

Additional information and/or stipulations are hereby attached and identified below as being a part of this agreement.

<input checked="" type="checkbox"/>	1.	Division of Cost
<input checked="" type="checkbox"/>	2.	Location Map
<input checked="" type="checkbox"/>	3.	Risk Assessment
<input checked="" type="checkbox"/>	4.	Attestations
<input checked="" type="checkbox"/>	5.	Resolution*
<input checked="" type="checkbox"/>	6.	Changes in Agreement Provisions
<input type="checkbox"/>		
<input type="checkbox"/>		
<input type="checkbox"/>		

\*Appropriation and signature authority resolution must be in effect on, or prior to, the execution date of the agreement.

Local Public Agency	Section Number	State Job Number	Project Number
Tazewell County	25-00057-07-RS	C9404226	

**AGREEMENT SIGNATURES EXECUTION**

The LPA agrees to accept and comply with the applicable provision set forth in this agreement including attached schedules.

**APPROVED**

Local Public Agency  
Name of Official (Print or Type Name)  
Brett Grimm

Title of Official  
County Board Chairman

Signature	Date
	

The above signature certifies the agency's TIN number is  
376002171 conducting business as a Governmental Entity.

DUNS Number 071430805  
UEI C121C5LKZU91

**APPROVED**

State of Illinois  
Department of Transportation

Omer Osman, P.E., Secretary of Transportation	Date

By:  
George A. Tapas, P.E., S.E., Engineer of Local Roads & Streets

	Date

Stephen M. Travia, P.E., Director of Highways PI/Chief Engineer	Date

Michael Prater, Chief Counsel	Date

Vicki Wilson, Chief Fiscal Officer	Date

**NOTE:** A resolution authorizing the local official (or their delegate) to execute this agreement and appropriation of local funds is required and attached as Schedule 5. The resolution must be approved prior to, or concurrently with, the execution of this agreement. If BLR 09110 or BLR 09120 are used to appropriate local matching funds, attach these forms to the signature authorization resolution.

Please check this box to open a fillable Resolution form within this form.



# SCHEDULE NUMBER 2

## Location Map

Section 25-00057-07-RS

Broadway Road (County Highway 19) – FAS 1467

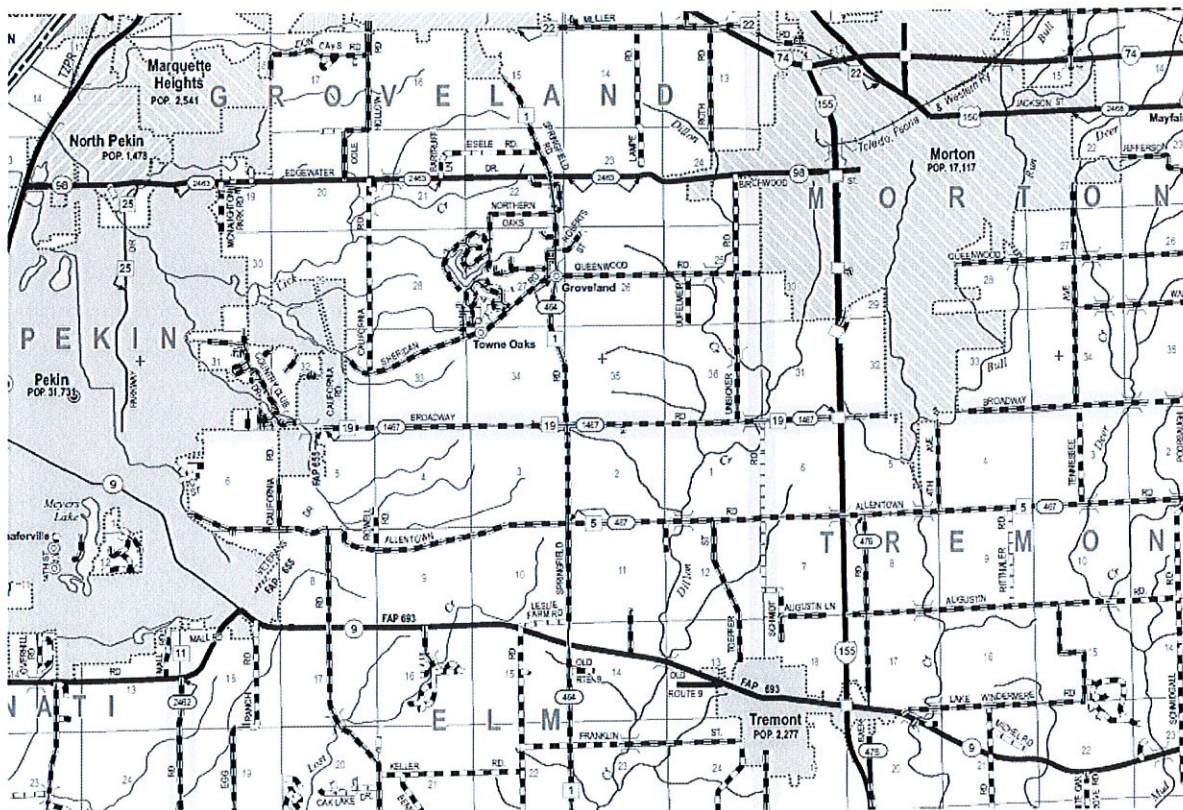



Local Public Agency	Section Number	State Job Number	Project Number
Tazewell County	25-00057-07-RS	C9404226	

**SCHEDULE NUMBER 4  
Attestation on Single Audit Compliance**

1. In the prior fiscal year, did Tazewell County LPA expend more than \$750,000 in federal funds in aggregate from all federal sources?

Yes    No

2. Does the Tazewell County LPA anticipate expending more than \$750,000 in federal funds in aggregate from all federal sources in the current Tazewell County LPA fiscal year?

Yes    No

If answers to question 1 and 2 are no, please proceed to the signature section.

If answer to question 1 is yes, please answer question 3a.

If answer to question 2 is yes, please answer question 3b.

3. A single audit must be conducted in accordance with Subpart F of 2 CFR 200 if \$750,000 or more in federal funds are expended in a single fiscal year.

a. Has the Tazewell County LPA performed a single audit for their previous fiscal year?

Yes    No

i. If yes, has the audit be filed with the Illinois Office of the Comptroller in accordance with 50 ILCS 310 (see also 55 ILCS 5 & 65 ILCS 5 & 60 ILCS 1/80)?

Yes    No

b. For the current fiscal year, does the Tazewell County LPA intend to comply with Subpart F of 2 CFR 200?

Yes    No

By completing this attestation, I certify that I have authority to sign this attestation on behalf of the LPA; and that the foregoing information is correct and complete to the best of my knowledge and belief.

Name	Title	LPA
Mindy Darcy	County Administrator	Tazewell County

Signature & Date

Mindy L. Darcy	Digitally signed by Mindy L. Darcy Date: 2026.01.26 15:06:44 -06'00'
----------------	---

Local Public Agency	Section Number	State Job Number	Project Number
Tazewell County	25-00057-07-RS	C9404226	

**SCHEDULE NUMBER 5**

**Resolution No. T-26-05**

A Resolution for:

Section Number 25-00057-07-RS  
 State Job Number C-94-042-26  
 Project Number \_\_\_\_\_

WHEREAS, the County of Tazewell is proposing to Mill and Resurface Broadway Rd. from Springfield Rd. easterly to Interstate I-155 overpass.

WHEREAS, the above stated improvement will necessitate the use of funding provided through the Illinois Department of Transportation (IDOT); and signee

WHEREAS, the use of these funds requires a joint funding agreement (AGREEMENT) with IDOT; and

WHEREAS, the improvement requires matching funds; and

NOW, THEREFORE, be it resolved by the County Board

Section 1: The County Board hereby appropriates \$0.00 or as much as may be needed to match the required funding to complete the proposed improvement from Matching - Line Item 215-400-5580 and furthermore agree to pass a supplemental resolution if necessary to appropriate additional funds for completion of the project.

Section 2: The County Board Chairman is hereby authorized to execute an AGREEMENT with IDOT for the above-mentioned project.

Section 3: This resolution will become **Schedule Number 5** of the AGREEMENT.

Section 4: The County Clerk of Tazewell is directed to transmit 2 (two) copies of the AGREEMENT and Resolution to IDOT District 4 Bureau of Local Roads and Streets.

I, John Ackerman County Clerk in and for said County  
Name of Clerk Local Public Agency Type Local Public Agency Type  
 of Tazewell County in the State aforesaid, and keeper of the records and files thereof, as provided by  
Name of Local Public Agency

statute, do hereby certify the foregoing to be a true, perfect and complete original of a resolution adopted by Board of Tazewell County at a meeting held on March 25, 2026  
Governing Body Type Name of Local Public Agency Date

IN TESTIMONY WHEREOF, I have hereunto set my hand and seal this 25<sup>th</sup> day of March 2026.  
Day Month, Year

(SEAL)

Clerk Signature & Date  
 3/25/2026

**Approved**

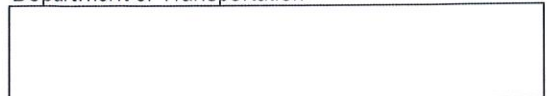
Regional Engineer Signature & Date  
 Department of Transportation  

LPA: Tazewell County  
Job Number: C-94-042-26  
Section Number:25-00057-07-RS

**Schedule 6**  
**Changes in Agreement Provisions**  
**Form BLR 05310C – STATE Funds Only**

WHEREAS it is necessary to revise certain portions of the Agreement.

BE IT MUTUALLY AGREED that the following shall be revised as follows:

Delete all references to the Federal Highway Administration (FHWA) and specific federal requirements.

**COMMITTEE REPORT**

Mr. Chairman and Members of the Tazewell County Board:

Your Property Committee has considered the following RESOLUTION and recommends that it be adopted by the Board:

-----  
**RESOLUTION**

WHEREAS, the County's Property Committee recommends to the County Board to decline the purchase of property from the Illinois Department of Transportation (IDOT); and

WHEREAS, the Illinois Department of Transportation has excess road right-of-way after a redesign of I-155 in Boynton Township, one-half mile east of the intersection of Brownwood Road and Shipton Road that runs down the middle of what is primarily the north half of Section 20-22-3 3PM; and

WHEREAS, pursuant to 605 ILCS 5/4-508 (c), before the Illinois Department of Transportation can sell the subject property at public auction, they are required to offer the property to Tazewell County at its recently appraised value of \$119,000.00; and

WHEREAS, the property is mostly landlocked and unusable for anything other than agriculture which makes the property of no value to Tazewell County; and

WHEREAS, if Tazewell County has no interest in acquiring the subject property, no response to the Illinois Department of Transportation is necessary.

THEREFORE BE IT RESOLVED that the County Board approve the recommendation to decline the purchase of the property from the Illinois Department of Transportation.

BE IT FURTHER RESOLVED that the County Clerk notifies the County Board Office, Highway, and Auditor of this action.

PASSED THIS 25<sup>th</sup> DAY OF MARCH, 2026.

ATTEST:

  
\_\_\_\_\_  
Tazewell County Clerk

  
\_\_\_\_\_  
Tazewell County Board Chairman

Zoom to

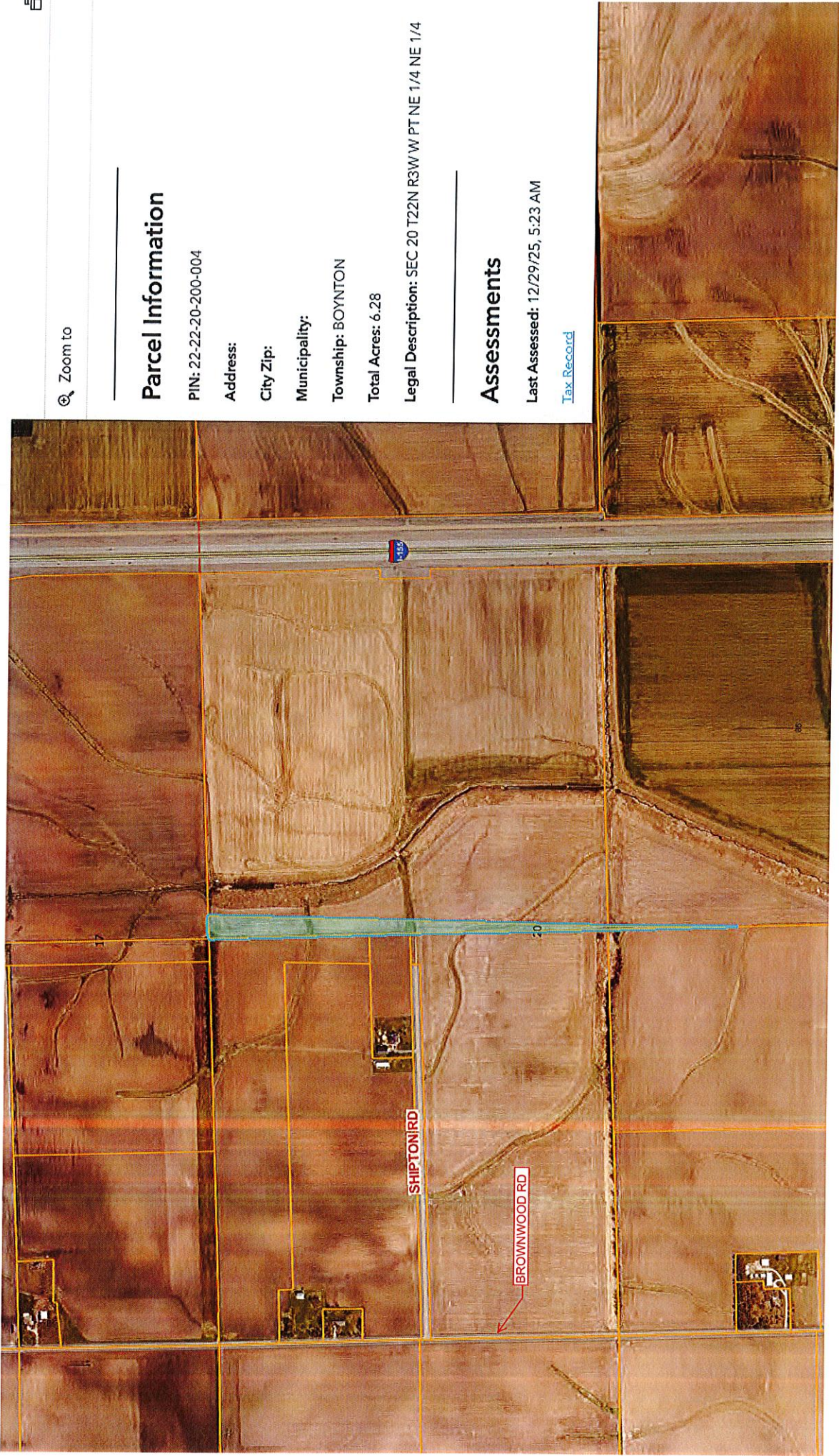

### Parcel Information

PIN: 22-22-20-200-004

Address:

City Zip:

Municipality:

Township: BOYNTON

Total Acres: 6.28

Legal Description: SEC 20 T22N R3W W PT NE 1/4 NE 1/4

### Assessments

Last Assessed: 12/29/25, 5:23 AM

[Tax Record](#)



# Illinois Department of Transportation

Office of Highways Project Implementation / Region 3 / District 4  
401 Main Street / Peoria, Illinois 61602-1111

February 25, 2026

LAND ACQUISITION  
FAP Route 406 (Old IL Route 121)  
Job No. R-94-009-74  
Tazewell County  
Parcel No. 409695V

Mr. Dan Parr, P.E.  
County Engineer of Tazewell County  
21308 IL Route 9  
Tremont, Illinois 61568

Dear Mr. Parr:

The Illinois Department of Transportation owns property located on Old IL Route 121 (see attached survey plat and Google Earth image for reference). Pursuant to 605 ILCS 5/4-508(c), before the Department can sell the subject property at public auction, we are required to offer the subject property to Tazewell County at its recently appraised value of \$119,000.00.

By virtue of the above referenced statute, Tazewell County has 15 days from the date of this letter to provide a letter of intent indicating their interest in purchasing the subject property at its recently appraised value. Please send said letter of intent to:

Illinois Department of Transportation – District 4  
c/o Land Acquisition  
401 Main Street  
Peoria, Illinois 61602-1111

You will have 45 days from the date of the letter of intent to provide an approved Resolution from Tazewell County. Upon receipt of the approved resolution, the Department will process documentation for approval of the Governor's Office.

If Tazewell County has no interest in acquiring the subject property no response is necessary.

Mr. Dan Parr, P.E.  
County Engineer of Tazewell County

February 25, 2026  
Page 2

If you have any questions regarding this request, you may contact Todd Halfman at (618)304-2395.

Sincerely,

A handwritten signature in blue ink that reads "Kensil A. Garnett". The signature is written in a cursive style with a stylized "K" and "G".

Kensil A. Garnett, P.E.  
Region Three Engineer

CL/TH:pjl\WINWORD\Land Acquisition\Excess Land\ExcessParcel\_409695V\_TazewellCnty.docx

Enclosures

cc: File

STATE OF ILLINOIS  
DEPARTMENT OF TRANSPORTATION

BEARING, DISTANCES, AND COORDINATES SHOWN  
HEREON ARE REFERENCED TO THE ILLINOIS  
STATE PLANE COORDINATE SYSTEM, WEST ZONE,  
NAD83 (2011 ADJUSTMENT). COORDINATES ARE  
FIXED HOLDING THE PUBLISHED NAD83(2011) VALUES  
FOR NGS CONTROL POINT PID: DG4188,  
DESIGNATION: 8 LA.

ALL MEASURED AND CALCULATED DISTANCES ARE  
"GRID". TO OBTAIN GROUND DISTANCES, DIVIDE  
GRID DISTANCES SHOWN BY THE COMBINATION  
FACTOR OF 0.99995924.

POINT NO.	NORTHING	EASTING
402	1,342,740.6140	2,492,609.3320
403	1,342,721.4226	2,492,609.9090
405	1,340,836.9749	2,492,588.8291
407	1,340,083.9573	2,492,561.9189
1001	1,340,083.0790	2,492,536.4340
1021	1,342,734.6684	2,492,459.9503

LEGEND:

- O FOUND IRON PIN/PIPE
- 3/4" IRON PIN W/ CAP
- P PROPERTY LINE
- ( ) RECORD DISTANCE

409695V

STATE OF ILLINOIS

AREA = 273,594 SQ. FT. OR 6.281 ACRES

THAT PART OF THE NORTHEAST QUARTER OF SECTION 20,  
TOWNSHIP 22 NORTH, RANGE 3 WEST OF THE THIRD  
PRINCIPAL MERIDIAN, IN TAZEWELL COUNTY, ILLINOIS.

SECTION 20 TOWNSHIP 22 NORTH, RANGE 3 W, 3RD PRINCIPAL  
MERIDIAN TAZEWELL COUNTY

**EXCESS LAND PLAT**

FAP RTE. 406  
SHEET 1 OF 1  
SCALE: 1" = 400'  
SEPTEMBER 22, 2025  
CONSTRUCTION SECTION:  
JOB NO. R-94-009-74  
CATALOG NO.

BOOK DOCUMENT NO.  
PAGE

Recorded  
Signed  
10/30/25

FIELD WORK COMPLETION: 10/29/25  
REVISED:

409695V

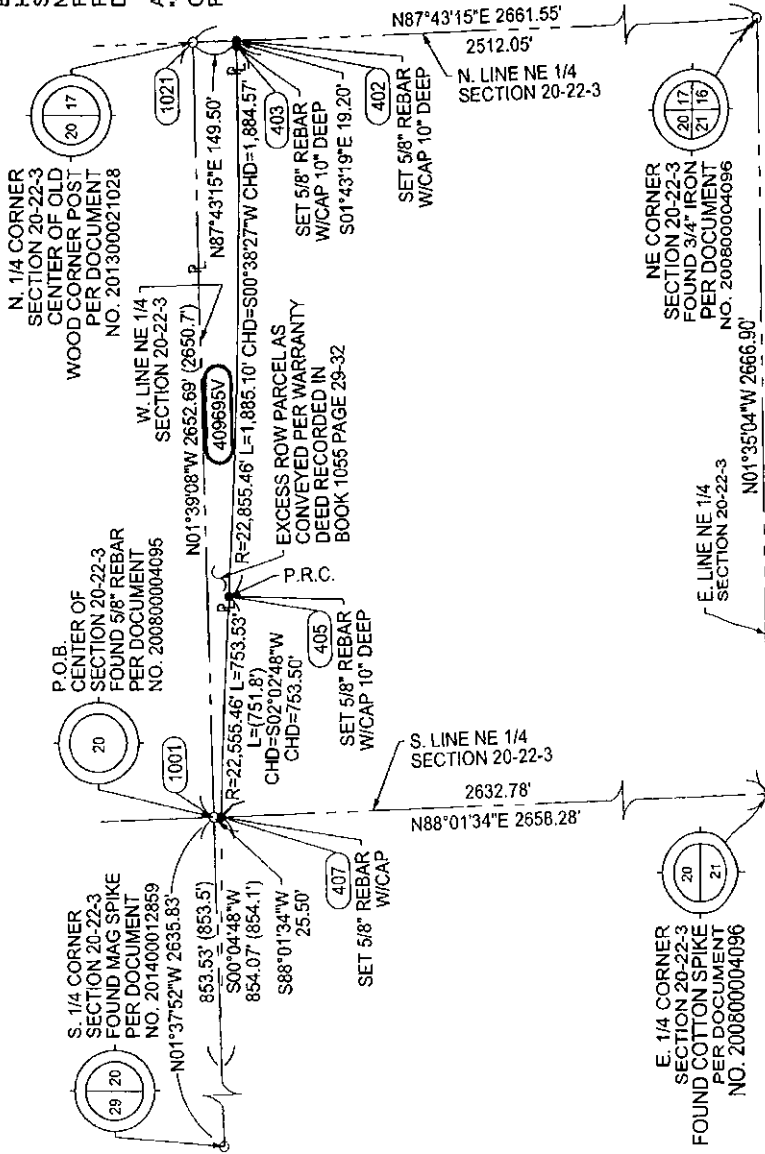

I-155

THIS IS TO CERTIFY THAT THIS IS A TRUE AND  
CORRECT PLAT OF SURVEY MADE UNDER MY  
DIRECTION FOR THE ILLINOIS DEPARTMENT  
OF TRANSPORTATION. THIS PROFESSIONAL  
SERVICE CONFORMS TO THE CURRENT ILLINOIS  
MINIMUM STANDARDS FOR A BOUNDARY SURVEY.

DAVID A. CLAASSEN - ILLINOIS PROFESSIONAL  
LAND SURVEYOR NUMBER 35-002962  
LICENSE EXPIRES 11/30/2026

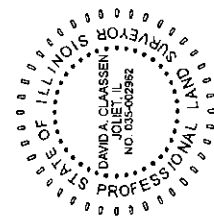

ROW	COMPUTED	K.A.G.	DATE
PLAT <td>CHECKED <td>D.A.C. <td>09/22/25 </td></td></td>	CHECKED <td>D.A.C. <td>09/22/25 </td></td>	D.A.C. <td>09/22/25 </td>	09/22/25
NOTEBOOK <td>INKED <td>J.L.S. <td>10/30/25 </td></td></td>	INKED <td>J.L.S. <td>10/30/25 </td></td>	J.L.S. <td>10/30/25 </td>	10/30/25
FILE# 753 <td>INK CHECKED <td>K.A.G. <td>09/22/25 </td></td></td>	INK CHECKED <td>K.A.G. <td>09/22/25 </td></td>	K.A.G. <td>09/22/25 </td>	09/22/25
NO. 1			

CAD DRAWING:

PROJECT:

FILE:

REDUCED TO  
64% OF  
ORIGINAL SIZE

*Map of Brownwood*

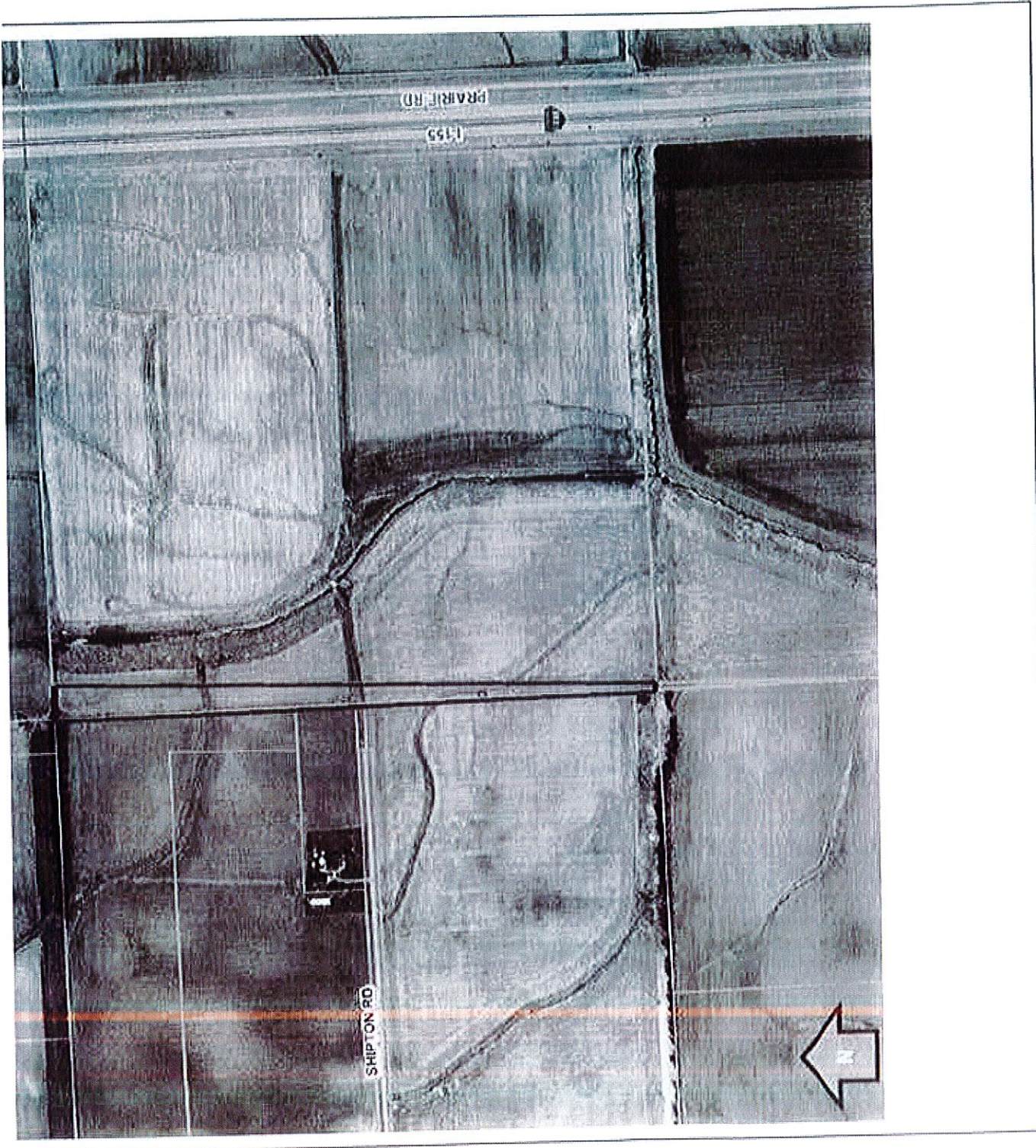

Surveyed Plot Boundaries

GIS Boundaries

**COMMITTEE REPORT**

Mr. Chairman and Members of the Tazewell County Board:

Your Property Committee has considered the following RESOLUTION and recommends that it be adopted by the Board:

-----  
**RESOLUTION**

WHEREAS, the County's Property Committee recommends to the County Board to approve the Courthouse Flagpole Project; and

WHEREAS, P.J. Hoerr received bids from subcontractors including Knapp Concrete Contractors, Inc., Aupperle, and Hein Construction, Inc. Knapp Concrete Contractors, Inc., as subcontractor was deemed the best overall option resulting in a total project cost of \$37,688.80; and

WHEREAS, P.J. Hoerr will oversee this project through our existing relationship with them as construction manager over renovations and property improvements to Tazewell County's existing buildings and properties; and

WHEREAS, the project is funded in the FY26 Capital Improvement Plan Fund with a budget of \$20,000; and

WHEREAS, the County Administrator recommends approving the bid and is authorized to proceed with the project.

THEREFORE BE IT RESOLVED that the County Board approve the Flagpole Project for the Courthouse.

BE IT FURTHER RESOLVED that the County Clerk notifies the County Board Office, Finance Office, Facilities Director and Auditor of this action.

PASSED THIS 25<sup>th</sup> DAY OF MARCH, 2026.

ATTEST:

  
\_\_\_\_\_  
Tazewell County Clerk

  
\_\_\_\_\_  
Tazewell County Board Chairman



Peoria Office: 107 N. Commerce Place, Peoria, IL 61604 • Phone: 309.688.9567 • Fax: 309.688.9556

Bloomington/Normal Office: 117 Merle Lane, Normal, IL 61761 • Phone: 309.888.9567 • Fax: 309.888.9556

March 9, 2026

Mindy Darcy  
 County Administrator / Finance Director  
 Tazewell County

Re: Proposal  
 Tazewell County Courthouse - New Flagpole

Dear Mindy,

Below is the cost for the above referenced project.

**Scope**

- Traffic control and layout
- Remove flagpole, demo sidewalk 6'x25', and remove flagpole base
- Install new flag pole base, 1" conduit for light under sidewalk to flag base
- 55'x10" Aluminum Flagpole with internal halyard - satin finish
- We recommend using Knapp Concrete Contractors as they are the low responsible bid.
- See attached proposals

<b>Courthouse - New Flagpole</b>							<b>\$</b>	<b>37,688.80</b>
<b>Labor</b>	<b>Traffic Control/Layout</b>	<b>Material</b>	<b>Sublet</b>	<b>PM</b>	<b>Procure</b>	<b>Fee</b>	<b>TOTAL</b>	
\$ 1,888.00	\$ 1,500.00	\$ -	\$ 31,640.00	\$ 1,666.00	\$ 31.53	\$ 963.27	\$ 37,688.80	
<b>16 Est. PJH Hrs</b>				<b>14 PM Hrs</b>	0.09%	2.75%		

**Notable Assumptions:**

- This pricing is valid for 30 days.
- The owner will allow access at the facility during normal working hours Monday - Friday.
- This proposal does not include identification, abatement or remediation of any hazardous materials.
- Subgrade compaction, density, and concrete testing by County
- This proposal does not include permits, winter conditions, asphalt and base, striping, landscaping/seeding, or design fees.
- The existing flag pole base size is unknown and if more concrete needs to be removed larger than the planned 6' then a change order will be provided for additional costs.
- This proposal does not include electrical work and light/outlet at flagpole
- This proposal does not include Performance and Payment Bonding.
- This proposal does not include sales tax.
- Builders Risk provided by Owner.

If you have any questions about the above information do not hesitate to contact our office.

Sincerely,

Charlie Waibel  
 P. J. Hoerr, Inc.



Light location (light by others)

Remove & Replace (4) Panels

6'-0"

25'-0"

Stub out and install approx. 20 lf of conduit for electrician

**Flagpoles Etc**

51056 Century Court  
 Wixom, MI 48393  
 (248) 634-7183  
 sales@flagpolesetc.com



**Estimate**

ADDRESS  
 Charlie Waibel  
 Tazewell Country Courthouse  
 342 Court St  
 Pekin, IL 61554  
 309-696-0971

SHIP TO  
 Charlie Waibel  
 Tazewell Country Courthouse  
 342 Court St  
 Pekin, IL 61554  
 309-696-0971

ESTIMATE E45233  
 DATE 02/26/2026  
 EXPIRATION 03/26/2026  
 DATE

SALES REP.  
 Bonnie

DESCRIPTION	SKU	QTY	RATE	AMOUNT
-------------	-----	-----	------	--------

Thank you for your interest in the products and services of Flagpoles Etc.  
 Should you have any questions or need additional information, please feel free to contact us.

		1	0.00	0.00
--	--	---	------	------

55'x10"x.188" (3 pc) Washington Series Box Winch - Internal Halyard Aluminum Flagpole with Reinforced Welded Door Frame - Satin Finish

	WFD3PC55 10188S	1	8,793.98	8,793.98
--	--------------------	---	----------	----------

Specifications:

Max Flag Size: 10' x 15'  
 Max Wind Speed with Nylon Flag: 102 MPH  
 Max Wind Speed without Flag: 139 MPH

INCLUDED:

10" ALUMINUM GOLD BALL, INTERNAL REVOLVING TRUCK, WIRE HALYARD CABLE ASSEMBLY AND FLAG ARRANGEMENT, RETAINER RING, COUNTERWEIGHT, 2 CHROME PLATED BRASS FLAG SNAPS, BOX WINCH, WINCH HANDLE, REINFORCED WELDED DOOR FRAME with LOCK and KEYS, ALUMINUM FLASH COLLAR, GALVANIZED STEEL GROUND SLEEVE with LIGHTNING SPIKE.

Note: We strive to exceed your expectations, but unforeseen delays may occur. In-stock flagpoles ship in 2-6 weeks; custom and tapered anodized flagpoles ship in 8-10 weeks; and powder-coated finishes in 4-6 weeks. You will be notified when your order is ready to ship. Delivery times are estimates and may vary due to supply chain disruptions or other unforeseen factors.

	NOTEDEL	1	0.00	0.00
--	---------	---	------	------

Customers are responsible for flagpole selection, ensuring compliance with local and state laws, and acknowledging that wind speed recommendations are approximate. Flagpoles Etc is not liable for flagpole size selection, compliance issues, or any damage to driveways, yards, or other property caused by delivery trucks or equipment.

Important: Flagpoles will stain if left in contact with wet or damp wrappings. Remove flagpoles from the tube and unwrap them immediately upon delivery. If stored outdoors, store unwrapped flagpoles off the

ground and outside the tube to prevent damage or corrosion.

General exclusions: engineering, permits, sales tax (if applicable), locates, special inspections, material testing, abnormal ground conditions (rock, concrete, asphalt), traffic control, and cold weather protection.

If you have any questions about flagpole selection, compliance, or storage, our team is here to help.

FREIGHT SHIPPING IS AN ESTIMATED CHARGE AND MAY CHANGE. ANY SAVINGS OR ADDITIONAL AMOUNTS IN FREIGHT CHARGES WILL BE EXTENDED TO THE CUSTOMER. FINAL COST IS THE RESPONSIBILITY OF THE CUSTOMER.

FREIGHTFP	1	769.00	769.00
-----------	---	--------	--------

A 3% handling fee will be applied to the total amount of any invoice over \$1,500 paid by credit card to cover credit card processing costs. This can be removed if paid by check, however, please note that order will not be processed until the check is received.

CREDITCARD	1	286.89	286.89
------------	---	--------	--------

Thank you for your business! We accept credit cards, ACH and check.  
Please mail check to 51056 Century Court Wixom MI 48393  
Price matching guarantee on exact match. Conditions Apply

SUBTOTAL	9,849.87
TAX	0.00
<b>TOTAL</b>	<b>\$9,849.87</b>

Accepted By

Accepted Date

## Designing Your Flagpole – Foundation Options

Installation methods available to securely and permanently mount the flagpole include Ground Set and Shoe Base options.

### Ground Set

Ground Set installations are the strongest and most common form of flagpole installation. They require burial of the flagpole shaft in a concrete foundation to a depth equal to 10% of the mounting height.

*All standard Flagpoles listed in this catalog are designed for Ground Set foundations. Each flagpole is shipped at 10% over listed Mounting Height.*

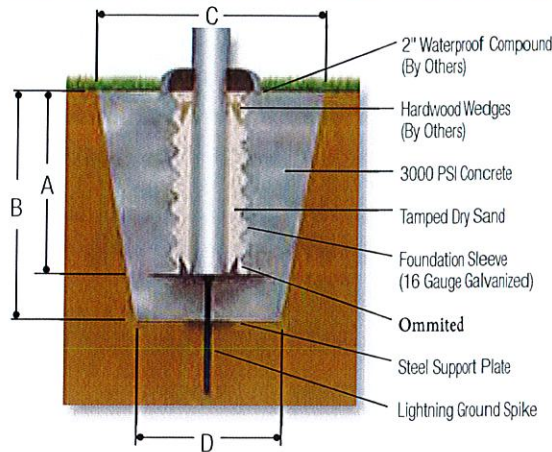

EXPOSED MOUNTING HEIGHT	Ground Set			
	A	B	C	D
20'-0"	2'-0"	2'-6"	30"	24"
25'-0"	2'-6"	3'-0"	36"	24"
30'-0"	3'-0"	3'-6"	36"	24"
35'-0"	3'-6"	4'-0"	36"	30"
40'-0"	4'-0"	4'-6"	45"	36"
45'-0"	4'-6"	5'-0"	45"	36"
50'-0"	5'-0"	5'-6"	50"	42"
60'-0"	6'-0"	6'-6"	60"	48"
70'-0"	7'-0"	7'-6"	60"	48"
80'-0"	8'-0"	8'-6"	72"	48"

*NAAMM's Metal Flagpole Manual offers basic suggestions on foundation measurements in firm, dry soil only using dry tamped sand and 3000 PSI concrete. Soil conditions vary by site. Exact foundation requirements should be verified by a Structural Engineer with knowledge of soil conditions in your locality.*

### Shoe Base

Shoe Base installations are typically used when an above ground installation is required.

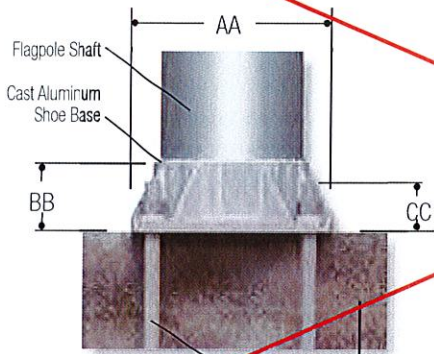

Four galvanized Steel Anchor Bolts (55,000 PSI Minimum Yield). 3000 PSI Concrete

*All Shoe Base Flagpoles are heat treated after weld to T-6 temper.*

BUTT DIA.	AA BASE SQUARE	BBB BASE HEIGHT	CCC BOLT PROJECTION	BOLT DIAMETER	BOLT CIRCLE DIAMETER
4"	7-1/2"	3"	2"	3/4"	6-1/2"-8
5"	7-1/2"	3"	2"	3/4"	7-1/2"-8
6"	9-3/4"	3-1/2"	2-3/4"	1"	9"-10"
7"	10-1/2"	3-11/16"	2-3/4"	1"	10"-11"
8"	11-1/4"	3-15/16"	2-3/4"	1"	11"-12"
10" Up To .205	14"	4-7/8"	3-1/4"	1"	14"-15"
10" .312 & Larger	14"	4-7/8"	3-1/4"	1-1/4"	14"-15"
12"	17"	8"	3-3/4"	1-1/4"	16"-18"

*All 20' to 80' Flagpoles with a 4"+ Butt Diameter can be provided in a Shoe Base Contact Customer Service for Wind Speed information for your particular design.*

## Designing Your Flagpole – Flagpole Height

The next consideration in choosing your flagpole design is to determine the mounting height. This can be specified solely on the required aesthetics of the particular job, or can be determined by the size of the flag wished to be flown.

The National Association of Architectural Metal Manufacturers (NAAMM) publishes the following criteria for determining the maximum flag size for each flagpole height.

Ground Set		Wall Mounted		Outrigger	
FLAGPOLE HEIGHT	FLAG SIZE	FLAGPOLE HEIGHT	FLAG SIZE	FLAGPOLE HEIGHT	FLAG SIZE
15'	3' x 5'	12' to 15'	4' x 6'	8'	3' x 5'
20'	4' x 6'	20' to 25'	5' x 8'	10' to 12'	4' x 6'
25'	5' x 8'	30' to 35'	6' x 10'	13' to 16'	5' x 8'
30'	6' x 10'	40' to 45'	8' x 12'	17' to 23'	6' x 10'
35'	6' x 10'				
40'	8' x 12'				
45'	8' x 12'				
50'	10' x 15'				
60'	12' x 18'				
70'	12' x 18'				
80'	15' x 25'				

**Safety Note:** Extreme care must be exercised when installing flagpoles near overhead power lines or when digging in the vicinity of buried utilities.

**Caution:** During installation, extreme care should be taken to insure that all components are securely attached.



# Knapp Concrete Contractors Inc.

150 E. Martin Dr.  
Goodfield, IL 61742  
Ph 309-965-2618 Fax 309-965-2614

To: PJ Hoerr, Inc. 107 Commerce Place Peoria, IL 61604  3/6/2026	Project: Tazewell Co. Courthouse 55' Flag Pole 342 Court St. Pekin, IL 61554
--	--

WE PROPOSE TO FURNISH ALL LABOR, MATERIAL AND EQUIPMENT NECESSARY TO COMPLETE

**Addendum Reviewed:**

**This Bid Includes:**

Remove flag pole, demo sidewalk 6' x 25', and remove flag pole base.  
 Install new flag pole base, 1" conduit for light under sidewalk to flag pole base,  
 pour sidewalk, assemble and set flag pole. \$ 31,640.00

The existing flag pole base size is unknown and if more concrete needs to be removed larger than the planned 6' then a change order will be provided for additional costs.

**This Bid Does Not Include:**

Testing, permits, winter conditions, layout, epoxy floor, steel edging, asphalt and base, striping, fence, dewatering, over excavation, taxes.

Respectfully

Submitted by:

*Merle Blunier*

This proposal may be withdrawn by us if not accepted within 30 days. All agreements contingent upon strikes, accidents, and other delays beyond our control. We carry Workman's Compensation and Public Liability Insurance.

No warranties or conditions shall be implied or assumed beyond those expressly stated herein.

No charges or extra work shall be completed without an authorized change order. Payment is due within 30 days of billing.

Interest will be charged after 60 days at the rate of 1 1/2% per month (18% per year).

CUSTOMER AGREES TO PAY ALL REASONABLE COLLECTION COSTS,  
ATTORNEY FEES AND COURT COSTS INCURRED BY KNAPP CONCRETE  
IN ENFORCING OUR TERMS AND CONDITIONS.  
UPON ACCEPTANCE, PLEASE SIGN AND RETURN. THANK YOU!

Accepted By: \_\_\_\_\_

Date: \_\_\_\_\_



# Proposal

200 Penn Avenue, Morton IL 61550  
 P: (309) 266-7460 F: (309)263-2223  
 bill@aupperle.org

Bid To: PJ Hoerr	Phone:	Date February 27, 2026
Address:	Job Name: Tazewell Courthouse	
State/Zip:	Address:	
Attention: Charlie	State/Zip: Pekin, IL	

You are hereby authorized to perform the specifically described work:

### FLAGPOLE REMOVAL AND REPLACEMENT

Mobilization - Prep - Layout

Sawcut Sidewalk - Vac Slurry

-Traffic Control

Demo Sidewalk

-Lay down Flagpole

-Crane Rental

Load Haul Offsite

Demo Existing Foundation

-Haul Spoils Offsite

Electrical Conduit

New Flagpole Base

-4" 4000 PSI Sidewalks

-#10 Mesh

-#4 Dowels @ 24" Each

-1 Count Salt Inhibiting CNS

Set Flagpole

-Crane Rental

Regrade - Misc.

Flagpole & Material Complete

TOTAL \$36,843

### DOES NOT INCLUDE:

Extra Work Due To Poor Or Unsuitable Soils - Overtime Premium Pay - Landscaping - Unknown Obstructions - Utility Relocations

Authorized Signature  
 Bill Aupperle

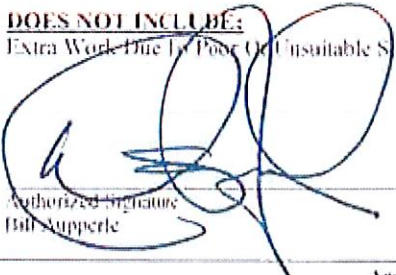

Note: This Proposal  
 May Be Withdrawn By  
 Us If Not Accepted Within \_\_\_\_\_ Days



### Acceptance Of Wm. Aupperle & Sons, Inc. Proposal

The Above Prices, Specifications, And Conditions Are Satisfactory And Are Hereby Accepted. You Are Authorized To Do The Work As Specified. Payment Will Be Made Within 30 Days Of Billing, 2% Interest To Be Charged On Overdue Accounts.

Date \_\_\_\_\_

Signature \_\_\_\_\_



**ESTIMATE**

9130 N Industrial Road  
Peoria, IL 61615

Contact: Ciaron Graham  
Phone: (309) 691-4774  
Email: ciaron@heinconstruction.com

Quote To: PJ Hoerr Job Name: Tazewell Corthouse Flag Pole Installation  
Att: Charlie Waibel Date of Plans:  
Phone: 309-696-0971 Addendum:  
Email: charlie@pjhoerr.com

ITEM	DESCRIPTION	QUANTITY	UNIT		
10	Mobilization	1.00	EA		
20	Sidewalk Removal	145.00	SF		
30	Flag Pole Removal	1.00	EA		
60	Conduit	20.00	LF		
70	Backfill CA-6	2.50	TON		
80	Flag Pole Materials & Installation	1.00	EA		
90	4" Concrete Sidewalk	150.00	SF		
100	Repair Landcaping / Decorative Rock	1.00	LS		

**GRAND TOTAL** **S39,642.78**

**NOTES:**

Excludes:

- Permits or Permit Fees
- Survey or Staking
- Payment or Performance Bonds
- Private Locates
- Winter Conditions

**COMMITTEE REPORT**

P-26-09

Mr. Chairman and Members of the Tazewell County Board:

Your Property Committee has considered the following RESOLUTION and recommends that it be adopted by the Board:

-----  
**RESOLUTION**

WHEREAS, the County Administrator recommends to the Property Committee to approve the use of CIP Fund contingency funds for the Animal Control facility project; and

WHEREAS, on April 30, 2025, the County Board approved Resolution P-25-07 which specified changes to project costs exceeding \$25,000.00 will be brought to the Property Committee; and

WHEREAS, the attached documentation provides details of Change Orders 1-8 issued by P.J. Hoerr representing a total net cost increase to the project of \$11,974.21. Additional unbudgeted costs to the project to date of \$105,012.00 for security technology costs and \$19,846.94 for data cabling costs have been quoted. The total net cost increase to the project is \$136,653.15 to date with additional costs expected prior to project completion; and

WHEREAS, the FY26 budget includes \$353,658.15 of contingency on the project in the CIP Fund. To date, \$174,153.15 of contingency funds has been used on the project leaving \$179,505.00 of contingency on the project.

THEREFORE BE IT RESOLVED that the County Board approves the recommendation.

BE IT FURTHER RESOLVED that the County Clerk notifies the County Board Office, Finance Office, Director of Animal Control, and the Auditor of this action.

PASSED THIS 25<sup>th</sup> DAY OF MARCH, 2026.

ATTEST:

  
\_\_\_\_\_  
Tazewell County Clerk

  
\_\_\_\_\_  
Tazewell County Board Chairman

## Animal Control Facility Project

### Reductions and Additions to Project Cost & Contingency Balance

Project #: 2025-P-02  
 Resoluion(s): P-25-07  
 Updated: 3.12.26

#### Responsible Fund:

	<u>CIP Fund</u>		<u>Animal Control Fund</u>	
	<u>Adjusted Project Cost</u>	<u>Contingency Balance</u>	<u>Adjusted Project Cost</u>	<u>Contingency Balance</u>
		<u>FY25 &amp; FY26</u>		<u>FY25 &amp; FY26</u>
<b>Total Budget by Fund</b>	<b>3,557,723.46</b>	<b>353,658.15</b>	<b>376,000.00</b>	<b>18,800.00</b>

#### Credits/Reductions to Project Cost:

PJ Hoerr  
 Issued  
 Change  
 Order #

3	PJH providing a credit for use of County-owned generator vs. purchasing a new generator - Remove the 100kw, 208/120V, 3-phase, Deisel powered generator from our scope of work. The ATS would still be included in our scope of work. - per Matt Brown 9.18.25	(37,500.00)	
2	Credit to project cost for the kennels which will be ordered directly by Tazewell County resulting in a lower overall cost for the project	(250,000.00)	
Total Reductions to Project Cost		(287,500.00)	

#### Change Orders/Additions to Project Cost:

PJ Hoerr  
 Issued  
 Change  
 Order #

1	During excavation for building footings, found buried cistern; needs to be removed and backfilled. IMEG recommended solution - PJH & Mike Schone agreed. Cost includes T&M, testing, rock, equipment, flowable backfill. - reported by Matt Brown of PJH 9.11.25	9,816.99	9,816.99
2	Cost of kennels being ordered directly by Tazewell County at a lower cost; cost not removed from project, just moved from under PJH contract to County directly	250,000.00	
4	security hardware related to the above & also to general door hardware requirements & their upcharge - CO #4	6,589.91	6,589.91
5	Electrical floor boxes for Vet room	3,696.02	3,696.02
6	Costs for low voltage rough ins	9,610.00	9,610.00
7	Rerouting downspouts to underground	4,405.26	4,405.26
8	Increased height of fence and added gates	15,176.03	15,176.03

Responsible Fund:

	<u>CIP Fund</u>		<u>Animal Control Fund</u>	
	<u>Adjusted Project Cost</u>	<u>Contingency Balance FY25 &amp; FY26</u>	<u>Adjusted Project Cost</u>	<u>Contingency Balance FY25 &amp; FY26</u>
<b>Additional Costs Paid Directly by Tazewell County:</b>				
Cost of Access Controls & related hardware, Security Cameras, Burglar Alarms, Fire Alarms & installation - County Cost - <b>Incomplete Cost</b>	105,012.00	105,012.00		
Cost to run data cabling from EMA to bldg, and then to data ports; includes required hardware for data throughout bldg - <b>Incomplete Cost</b>	19,846.94	19,846.94		
Total Additions to Project Cost / Contingency Used To Date	424,153.15	174,153.15	-	-
<b>Adjusted Project Cost</b>	<b>3,694,376.61</b>		<b>376,000.00</b>	
<b>Remaining Contingency Balance by Fund</b>		<b>179,505.00</b>		<b>18,800.00</b>
Total Net Cost (Increase) Decrease to Project Budget	(136,653.15)		-	
Net Increase (Decrease) to Project Due to Change Orders	11,794.21			
Amount of Contingency Funds Used of Change Orders		49,294.21		
Net Increase (Decrease) to Project Due to Costs Paid Directly by Tazewell County	124,858.94			
Amount of Contingency Funds Used for Project Costs Paid Directly by Tazewell County		124,858.94		

# Animal Control Facility Project

## Additional Cost Details

Project #: 2025-P-02  
 Resoluition(s): P-25-07

Responsible Fund:

Animal  
Control Fund

CIP Fund

### TECHNOLOGY/SECURITY COSTS:

Teufel Hunden	CCTV system using Exacq Vision (most used by Sheriff) - 21 cameras @ 240TB NVR; per Tim G, Sheriff's budget will pay for maintenance cost after installation; REVISED 2.5.26 to 7 cameras	55,492.00	
Teufel Hunden	Panic Alarm System & Burglar Alarm; monitoring contract \$35/mo 1st year & \$45/mo after)	3,190.00	AC to pay monthly monitoring contract @ \$35/mo for 1st year & \$45/mo thereafter; discount for multi-year contract. I believe we agreed to the 5 yr monitoring & annual inspection pkg for \$3285. AC will have to pay for ongoing maintenance of this system plus monthly monitoring costs; HAS CONTRACT BEEN SIGNED FOR MONTHLY SERVICE?
Teufel Hunden	Fire alarm - under PJH bldg contract only has Fire Suppression system; no fire alarm	26,300.00	
Teufel Hunden	Access Controls to 4 doors	20,030.00	
Teufel Hunden	Mike S to get cost to add intercom & door release button to Access Controls	TBD	
		<b>105,012.00</b>	

### DATA COSTS:

Heart Technologies	fiber cable run from EMA to bldg	19,846.94	
Heart Technologies	port switches & patch cables at switch; (fm remaining AC contribution of \$148k)	TBD	
Heart Technologies/Teufel Hunden	data cabling from switch to office locations; (fm remaining AC contribution of \$148k)	TBD	
		<b>19,846.94</b>	

Responsible Fund:

Animal  
Control Fund

CIP Fund

KENNEL COSTS:

MidMark	Kennels - Co to purchase directly - CIP Fund pays \$250k, AC Fund has \$150k budgeted with any extra coming out of the addtl'l contribution of \$148k in B	250,000.00	98,891.89	348,891.89	quote fm MidMark for kennels - updated 3.3.26
MidMark	Kennels - Freight on kennels (estimate) - covered under AC Fund B as detailed above		4,438.00		
PJH	Kennels - Assembly & Installation - covered in AC Fund B as detailed above		75,000.00		
Balance to MidMark	Total Kennels - Amt over \$150k budgeted for kennels to be paid out of AC Fund Addtl'l Contribution to Bldg of \$148k		178,329.89	28,329.89	overage to come out of the AC Fund addtl'l contribution of \$148k
<b>Use of Animal Control Fund Additional Contribution of \$148k for New Facility</b>					
	148,000.00	Additional AC Fund Contribution per Budget			
	(28,329.89)	Overage of kennel purchase as detailed above			
	TBD	moving costs			
	TBD	phones			
	TBD	other costs to outfit facility (appliances, etc)			
	(17,000.00)	POSSIBLE EXP - kennel banks missed in Midmark plans			
	102,670.11	Remaining additional AC Fund contribution to new building			

**COMMITTEE REPORT**

Mr. Chairman and Members of the Tazewell County Board:

Your Finance Committee has considered the following RESOLUTION and recommends that it be adopted by the Board:

-----  
**RESOLUTION**

WHEREAS, the County's Finance Committee recommends approval of the expenditure of funds for ADP, Inc. services.; and

WHEREAS, ADP agrees to provide the following services in addition to a variety of other services in accordance with the terms of this agreement:

- ADP Payroll Services delivered via ADP Workforce Now
- Tax Filing Services
- New Hire onboarding
- ADP Time & Attendance
- ADP Workforce Now IT Management, Powered by Electric
- Benefit Services – delivered via ADP Workforce Now
- Employment Verification Services
- Employee and Manager Self Service
- Access to mobile Apps
- Paid time off accruals
- Online reports and pay statements
- History Conversion Services
- Human Resources Administration Services – delivered via ADP Workforce Now; and

WHEREAS, this purchase was excluded from the competitive bidding requirement under the County's Purchasing Policy. The Global Master Services Agreement between ADP, Inc. and Tazewell County was in accordance with ADP's cooperative purchasing agreement with OMNIA Partners. OMNIA Partners is the largest group purchasing organization in the United States, providing cooperative purchasing contracts and procurement solutions for public and private sector organizations as allowed by Illinois State statute; and

WHEREAS, utilizing ADP for Tax Filing Services, Payment Services, New Hire Reporting, General Ledger Solutions and Conversational Virtual Assistant will streamline the payroll process and benefit the employees as well as the employer itself; and

WHEREAS, this service agreement will have an estimated annual cost of \$97,088.50, plus a one-time implementation cost of \$11,000.76. Tazewell County will receive four months of payroll processing costs free each of the first three years of service. Per the ADP Payroll Services Agreement, ADP services can be terminated at any time, therefore Tazewell County is not under any contractual obligation to continue services. This agreement has savings and promotional incentives that provide Tazewell County an

annual savings of approximately \$32,000.00. Monthly costs and savings will be calculated based on the actual number of employees being paid; and

THEREFORE, BE IT RESOLVED that the County Board approves this recommendation.

BE IT FURTHER RESOLVED that the County Clerk notifies the County Board Office, Finance Office, Payroll, Treasurer, and the Auditor of this action.

PASSED THIS 25<sup>th</sup> DAY OF MARCH 2026

ATTEST:

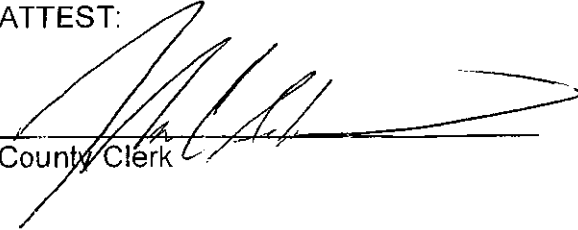
  
\_\_\_\_\_  
County Clerk

  
\_\_\_\_\_  
County Board Chairman

## Included Services

### Essential Plus Payroll

- Tax Filing Service
- Payment Services
- Employee Discount Program
- New Hire Reporting
- General Ledger Solution
- Conversational Virtual Assistant

### Enhanced HR

- Employee Development Tracking
- Paid Time Off Accruals Engine
- Multiple Languages & Currencies
- Country Specific Workflows & Processes
- Country Specific Formatting & Custom Fields
- Voice of Employee
- Document Cloud
- Communication Broadcasts

### HCM Analytics

- Pre-Configured Key Performance
- Executive Dashboard

### Benefits Administration

- Multiple Benefit Plan Types
- Flexible Rate Structures (Age Banded & Salary Tiers)
- ACA Measurement Dashboard
- Evidence of Benefit Offering Screens
- Annual 1094-C Filing

### IT Management Core

- Buy, ship, manage and reassign employee hardware

### Essential Time

- Time Collection
- Scheduling
- Mobile Access
- Paid Time Off Accruals

### Time Analytics

- Pre-Configured Key Performance
- Executive Dashboard

### Employment and Income Verification

- Commercial Employment and Income Verifications
- Social Services Verifications
- Workers Compensation Verifications

- Employee and Manager Self Service
- Access to Mobile Apps
- Wage Garnishment Processing
- Group Term Life Auto Calculation
- Intelligent Insights for Employee Issue Resolution
- Online Reports and Pay Statements

- New Hire Onboarding / I-9 Workflow
- Compliance Reporting
- Organization Charting
- Policy Acknowledgement
- Total Rewards Statements
- Secure Online Document Storage with Role Based Security, Search & Audit Functionality
- Employee Feedback and Sentiment Surveys
- ADP Connect News Feed and Recognition Tools

- Ability to Customize Additional KPIs
- Pay Equity Storyboard

- Dependent & Beneficiary Tracking
- Notifications & Approvals
- Invoice Auditing
- Annual 1095-C Forms
- Employee Open Enrollment with Personalized Decision Support

- Easily retrieve laptops when offboarding employees

- Rule Based Calculations
- Request & Approval Workflows
- ADP Portal with Customized Content

- Ability to Customize Additional KPIs

- Client access to Electronic Reports and Tools
- Immigration Verifications

Thank you for your consideration



Company Information

Tazewell County  
11 S 4th St  
Pekin, IL 61554-4253  
United States

Executive Contact

Teresa Melvin  
Primary  
[tmelvin@tazewell-il.gov](mailto:tmelvin@tazewell-il.gov)  
309-478-5918 Direct

# INVESTMENT SUMMARY

<b>Employees</b>	<b>Implementation</b>	<b>Total Annual</b>
<b>450</b>	<b>\$11,000.76</b>	<b>\$97,088.50</b>
	<b>Expiration</b>	
	<b>3/26/2026</b>	

\*\* The Implementation Costs and Total Annual Investment listed out on this Investment Summary are estimates based on the services, frequencies, recurring rates and pay counts outlined on the sales order and are shown for illustrative purposes only. These numbers are not binding amounts and shall not become incorporated into or made a part of any sales order or services agreement governing the services contemplated therein.

**“**  
 Easy to onboard new staff and very user-friendly for new and current staff to navigate and use. The App makes it even easier to have all your information in one easy spot. Making employees more responsible for their own information - saves time on HR and payroll departments to make simple changes employees can manage on their own. ”

— Teresa Stivala, SHRM-CP  
 VP of Human Resources, In Flight, Inc.

**ADP Sales Associate**

Conner Edwards  
MAS UM DM QB Tier 1  
[conner.edwards@adp.com](mailto:conner.edwards@adp.com)  
630-418-8088





# GLOBAL MASTER SERVICES AGREEMENT

Effective Date:

As between:

**ADP, INC.**  
(Referred to in this agreement as "ADP")  
One ADP Boulevard  
Roseland, NJ 07068

-and-

**Tazewell County**  
(Referred to in this agreement as "Client")  
11 S 4th St  
Pekin, IL 61554-4253

ADP and Client agree that ADP shall provide Client with the following services in accordance with the terms set forth in this Global Master Services Agreement and the applicable Sales Order (as defined herein):

- ADP Payroll Services – delivered v/a ADP Workforce Now
- ADP DataCloud
- ADP Document Cloud
- ADP Marketplace
- ADP Time & Attendance Services
- ADP Workforce Now IT Management. Powered by Electric
- Benefit Services – delivered via ADP Workforce Now
- Employment Verification Services
- ESS & MSS Technology
- Essential ACA Services
- History Conversion Services
- Human Resources Administration Services – delivered via ADP Workforce Now

ADP, INC.

Tazewell County

CC Edwards  
Signature of Authorized Representative

[Signature]  
Signature of Authorized Representative

Connor Edwards  
Name - Please Print

Brett Grimm  
Name - Please Print

Major Accounts District Manager  
Title

County Board Chairman  
Title

Notwithstanding any Investment Summary that may precede this Global Master Services Agreement, this signature page is the first page of the Global Master Services Agreement and the Investment Summary that precedes it is for illustration purposes only and shall not become part of the Global Master Services Agreement.



In the event that the Client terminates this Sales Order and work hereunder has already commenced, Client agrees that it is responsible for all costs and fees incurred by ADP prior to the effective date of such termination and such amounts shall be due and payable by Client to ADP according to the Client's previously-established payment terms with ADP.

History conversion: History Conversion Services include up to seven years of historical data from a single database source. Additional fees may apply for (i) conversion of historical data from more than one database or (ii) more than seven years of historical data.

**Summary**

Estimated Annual Net Investment: \$97,088.50 Total Net Implementation: \$11,000.76

Please note: The Estimated Annual Net Investment and Total Net Implementation fees listed above does not include any fees for ADP Professional Services as these amounts will vary based on the scope and complexity of the project.

The ADP Services Listed on this Sales Order are provided at the prices set forth herein and in accordance with the ADP Master Services Agreement (or other similar agreement governing ADP's services), which shall include any appendix, exhibit, addendum, schedule or other similar document attached thereto or accompanying this Sales Order. By signing below you are acknowledging and agreeing to such terms and conditions and to the listed prices.

ADP, Inc.

Client: Tazewell County

Signature: Conner Edwards  
Name: Conner Edwards  
Title: Major Accounts District Manager  
Date: 3/26/2026

Signature: [Signature]  
Name: Brett Grimm  
Title: County Board Chairman  
Date: 3-25-2026

**ADDENDUM**  
to  
**GLOBAL MASTER SERVICES AGREEMENT**  
between  
**ADP, INC.**  
and  
**Tazewell County**

This addendum ("Addendum"), made and effective as of the date of the last signature hereto between ADP, Inc. ("ADP") and Tazewell County ("Client"), contains changes, modifications, revisions and additions to the ADP Global Master Services Agreement dated of even date herewith between ADP and Client (as amended herein, the "Agreement").

In consideration of the mutual covenants contained in the Agreement and in this Addendum, and for other good and valuable consideration, notwithstanding anything to the contrary in the Agreement, ADP and Client agree as follows:

1. The first page/signature page of the Agreement is hereby amended by revising the first sentence to read the following: "ADP and Client agree that ADP shall provide Client with the following services in accordance with the terms set forth in this Global Master Services Agreement (including the applicable Sales Order (as defined herein)) and in accordance with ADP's cooperative purchasing agreement with OMNIA Partners, Contract No. R250901, which resulted from a competitive selection process by which OMNIA Partners selected ADP as a qualified vendor of managed business/outsourced services."

All other terms and conditions of the Agreement remain in full force and effect. In the event of any conflict between the terms and conditions of this Addendum and the terms and conditions of the Agreement, this Addendum shall prevail. The terms defined in the Agreement and used in this Addendum shall have the same respective meanings as set forth in the Agreement, unless clearly otherwise defined in this Addendum. This Addendum may be executed in multiple original copies, identically worded, and each such executed copy constitutes an original. Electronic signatures in connection with the electronic signature delivery system utilized by ADP and signatures transferred in .pdf or a similar format for scanned copies of documents are original signatures for all purposes of this Addendum and the Agreement.

IN WITNESS WHEREOF, this Addendum to the Agreement is hereby executed by an authorized representative of each party hereto as of the last date below.

ADP, Inc.

Tazewell County

C Edwards

[ADP Signature]

Connor Edwards

[ADP Name]

Major Accounts District Manager

[ADP Title]

3/26-2028

[ADP Date]

[Signature]

[Client Signature]

Brett Grimm

[Client Name]

County Board Chairman

[Client Title]

3-25-2026

[Client Date]

# Global Master Terms and Conditions

## 1 Definitions

- 1.1 ADP HCM Services.** Only those Services, as defined below, that have been purchased by Client (as listed on the cover page, a Sales Order or otherwise) will be applicable.
- 1.1.1 ADP Connect.** Solution that enables Users to (i) view Client news, broadcasts and surveys through a feed set up by Client, (ii) receive notifications, and (iii) receive and award recognitions, points and rewards that may be purchased through a third-party online store.
- 1.1.2 ADP Data Cloud.** Provide tools to analyze and understand data.
- 1.1.2.1 Analytics.** Enables an employer to gain insight from data for key Human Capital Management (HCM) metrics.
- 1.1.3 ADP Document Cloud.** Integrated solution to support maintenance and retrieval of employee-specific documents via cloud-based technology.
- 1.1.4 ADP Marketplace.** Enable Client to build applications and/or purchase available applications via online store. Provide access to certain Client data stored in ADP systems via industry-standard Application Programming Interfaces (APIs).
- 1.1.5 ADP Payroll Services.** Administration and processing of payroll including performing gross-to-net calculations and generating and/or transmitting of payment instructions, and also including:
- 1.1.5.1 ADP Employment Tax Services.** Coordination of payroll-related tax and/or regulatory agency deposits, filings and reconciliations on behalf of employers.
- 1.1.5.2 ADP Wage Garnishment Payment Services.** Garnishment payment processing and disbursement of payments to appropriate Payees as directed by Client.
- 1.1.5.3 ADP Wage Payment Services.** Payment of wages, commissions, consulting fees, or similar compensation or work-related expenses in the employment context to employees and independent contractors via direct deposit, check or payroll debit cards, in each case only to the extent applicable.
- 1.1.5.4 Print and Online Statement Services.** Print and distribution of payroll checks, pay statements, and/or year-end statements, as well as online posting of pay statements and/or year-end statements.
- 1.1.5.5 State Unemployment Insurance (SUI) Management Services.** ADP becomes the unemployment insurance address of record. ADP requests the state to send unemployment insurance claims, charges, tax rates and related information to ADP and Client receives a quarterly summary of all claims.
- 1.1.6 ADP Time & Attendance Services.** Support of time-related services, including time data collection, employee scheduling, timecard reviews and approvals, and consistent application of time-related policies.
- 1.1.7 ADP Workforce Now.** ADP's web-based portal which provides a single point of access to ADP online solutions and employee-facing websites and resources related to payroll, HR, benefits, talent, and time and attendance.
- 1.1.8 Benefit Services.** Technology to facilitate the administration of employee benefits, including applying eligibility rules, facilitating online enrollment and changes and calculating payroll deductions within a unified system, as well as providing data to carriers through ADP carrier connection services.
- 1.1.9 ESS & MSS Technology.** Employee self-service (ESS) and Manager self-service (MSS) functionality provides all Client Users (practitioners, managers and employees) 24x7 online access to ADP Application Programs.
- 1.1.10 Essential ACA Services.** A technology and software solution to assist Client in managing compliance needs related to the Affordable Care Act (ACA), including eligibility calculations and affordability determinations, preparation and electronic filing of Forms 1094-C and 1095-C, access to evidence of benefit offering information and benefit offering audit reports.
- 1.1.11 History Conversion Services.** Solution to (i) upload Client employees' and independent contractors' historical pay statements, Forms W-2, Forms 1099, payroll registers and company tax filings, (ii) convert and upload certain Client employees' and independent contractors' data, including positions, pay rates and employment status, into ADP Workforce Now and (iii) enable Client practitioner access to such historical payroll documents and data in ADP Workforce Now.
- 1.1.12 Human Resources Administration Services.** Administration of human resource functions using a unified system to process and audit employee lifecycle events, provide compliance tracking and reporting, including new hire reporting, and automate notification and approval processes via self-service/direct access, and also including:
- 1.1.12.1 WFN EI-9 Services.** Electronic I-9 administration and onboarding services to help facilitate and manage I-9 and related employment eligibility verification processes.
- 1.1.12.2 ADP Workforce Now IT Management, Powered by Electric.** Access to a solution provided by Electric AI, Inc. that enables Client practitioners to, among other things, procure and manage hardware for Client employees and independent contractors.
- 1.2 General.**
- 1.2.1** "ADP" has the meaning set forth on the cover page.

- 1.2.2 “**ADP Application Programs**” means the computer software programs and related Documentation, including any updates, modifications or enhancements thereto, that are either delivered or made accessible to Client through a hosted environment by ADP in connection with the Services.
- 1.2.3 “**ADPCheck**” means checks printed and distributed by ADP to Payees pursuant to Client’s direction.
- 1.2.4 “**ADPCheck Services**” refers to ADP’s payment of Client’s Payees for Permitted Payments through ADPCheck.
- 1.2.5 “**ADP Direct Deposit Services**” means ADP’s full service direct deposit services which includes ADP’s payment of Client’s Payees who have elected to receive Permitted Payments by direct deposit into an account at a financial institution of such Payee’s selection.
- 1.2.6 “**Affiliate**” means, with respect to any entity, any other entity that controls, is controlled by or under control with such first entity. For purposes of this Agreement, “control” (or variants of it) means the ability, whether directly or indirectly, to direct the management and corporate policies and actions of an entity by means of ownership, contract or otherwise. Client’s Affiliates do not include third parties for whom Client is a service provider or provides outsourcing services.
- 1.2.7 “**Agreement**” means this Global Master Services Agreement, consisting of the signature pages, the Global Master Terms and Conditions, all exhibits, annexes, appendices, addenda and schedules, and each Amendment, if any.
- 1.2.8 “**Amendment**” means a written amendment to this Agreement modifying, supplementing or amending the terms and conditions of this Agreement.
- 1.2.9 “**API**” means application programming interface.
- 1.2.10 “**Biometric Data**” includes the information collected by timeclocks and software that use finger and/or hand scan technology, which potentially may include Biometric Identifiers and Biometric Information.
- 1.2.11 “**Biometric Identifier**” means a retina or iris scan, fingerprint, voiceprint, or scan of hand or face geometry.
- 1.2.12 “**Biometric Information**” means any information, regardless of how it is captured, converted, stored, or shared, based on an individual’s biometric identifier used to identify an individual.
- 1.2.13 “**Biometric Services**” means services provided by ADP to Client via the use of timeclocks and software in connection with ADP’s provision of Time & Attendance Services, to the extent such timeclocks or software collect, store or use Biometric Data.
- 1.2.14 “**Biometric User**” means Client’s employees or independent contractors who use Biometric Services to record their attendance, hours worked or other work-related data.
- 1.2.15 “**Business Day**” means any day, except a Saturday, Sunday or a day on which ADP’s bank is not open for business in the applicable jurisdiction where services are provided by ADP.
- 1.2.16 “**Client**” has the meaning set forth on the cover page.
- 1.2.17 “**Client ACA Liaison**” means the Client’s designated person who shall serve as ADP’s principal contact for Essential ACA Services.
- 1.2.18 “**Client Content**” means all information and materials provided by Client, its agents or employees, regardless of form.
- 1.2.19 “**Client Group**” means Client and Client’s Affiliates listed in the Sales Order who are authorized to receive the Services.
- 1.2.20 “**Client Infringement Event**” means (i) any change or enhancement in, or use of, the Services by Client or a third party on Client’s behalf other than at the direction of, or as approved by, ADP or (ii) Client’s failure to use the most current release or version of any computer software programs included in the ADP Application Programs or any corrections or enhancements provided by ADP thereto (to the extent ADP requires Client to use the most current release or version of any computer software programs, the implementation of such shall be at no charge to Client).
- 1.2.21 “**Confidential Information**” means all trade secrets, processes, proprietary data and documentation and any pricing and product information, Personal Data, the terms of this Agreement, and any other information that is confidential or proprietary provided by the disclosing party to the receiving party for use in connection with the Services or this Agreement, but does not include information that (i) the receiving party already knows prior to its disclosure by the disclosing party, (ii) becomes generally available to the public, except as a result of disclosure by the receiving party in violation of this Agreement or (iii) becomes known to the receiving party on a non-confidential basis from a source other than the disclosing party.
- 1.2.22 “**Data Security Breach**” means a security breach as defined by applicable law or any incident that compromises the confidentiality, integrity, or availability of Personal Data.
- 1.2.23 “**DHS**” means the U.S. Department of Homeland Security.
- 1.2.24 “**Documentation**” means all manuals, tutorials and related materials that may be provided or made available to Client by ADP in connection with the Services.
- 1.2.25 “**Effective Date**” has the meaning set forth on the cover page.
- 1.2.26 “**ERISA**” means Employee Retirement Income Security Act of 1974, as amended.

- 1.2.27 **“E-Verify”** means the DHS’s employment eligibility verification program which allows participating employers to electronically verify the employment eligibility of each newly hired employee and/or employee assigned to a covered federal contract.
- 1.2.28 **“Form I-9”** means the employment eligibility verification form issued by the DHS.
- 1.2.29 **“FCRA”** means the Fair Credit Reporting Act, 15 U.S.C. § 1681 et seq.
- 1.2.30 **“Global Master Terms and Conditions”** means the terms and conditions contained in the main body of this document following the signature pages.
- 1.2.31 **“Go-Live Date”** means the date of commencement of the first live processing of any given Service.
- 1.2.32 **“I-9 Handbook”** means the current USCIS Handbook for Employers: Instructions for Completing Form I-9 (M-274).
- 1.2.33 **“Implementation Services”** means the Services to be performed in order to commence ongoing Services.
- 1.2.34 **“Improvements”** has the meaning set forth in Section 5.4.
- 1.2.35 **“Indemnitee”** has the meaning set forth in Section 6.3.
- 1.2.36 **“Indemnitor”** has the meaning set forth in Section 6.3.
- 1.2.37 **“Intellectual Property Rights”** means all rights, title and interest to or in patent, copyright, trademark, service mark, trade secret, business or trade name, know-how and rights of a similar or corresponding character.
- 1.2.38 **“Internal Business Purposes”** means the usage of the Services, including the ADP Application Programs, exclusively by the Client Group for its own internal business purposes, without the right to provide service bureau or other data processing services, or otherwise share or distribute the Services.
- 1.2.39 **“NACHA”** means the National Automated Clearing House Association.
- 1.2.40 **“Objectionable Content”** means any message, post, or other content that is (i) inappropriate or otherwise objectionable, (ii) potentially violates the privacy or publicity rights of a third-party, or (iii) advertises any other site or business content.
- 1.2.41 **“Payee”** means any intended recipient of payments under the Payment Services and may include Client’s employees, taxing authorities, governmental agencies, suppliers, benefit carriers and/or other third parties; provided that in the case of ADP Wage Payment Services, Payee shall be limited to Client’s employees and independent contractors.
- 1.2.42 **“Payment Services”** means Services that involve electronic or check payments being made by ADP to third parties on Client’s behalf and at its direction.
- 1.2.43 **“Permitted Payment”** means the legal payment of wages, commissions, consulting fees or similar compensation or work-related expenses in the employment context.
- 1.2.44 **“Personal Data”** means any information relating to an identified or identifiable natural person. An identifiable person is one who can be identified, directly or indirectly, in particular by reference to an identification number or to one or more factors specific to such person’s physical, physiological, mental, economic, cultural or social identity.
- 1.2.45 **“Plan”** means Client’s plan, including a group health plan, as identified by Client for the applicable Services.
- 1.2.46 **“Plan Administrator”** means the appropriate plan administrator as defined in Section 3(16)(A) of ERISA and Section 414(g) of the Internal Revenue Code of 1986, as amended.
- 1.2.47 **“Sales Order(s)”** means the document(s) between the parties that lists the specific Services purchased by Client Group from ADP.
- 1.2.48 **“Services”** means the services listed on the cover page of this Agreement (including Implementation Services related thereto and ADP Application Programs). and such other services as the parties may agree to be performed from time to time.
- 1.2.49 **“SOC 1 Reports”** has the meaning set forth in Section 9.1.
- 1.2.50 **“Strategic Carrier Partner”** means a carrier that participates in ADP’s strategic carrier partner program.
- 1.2.51 **“Technology Credit”** means funds paid by a Strategic Carrier Partner and applied by ADP to Client’s invoice for benefit administration fees.
- 1.2.52 **“Term”** means the period beginning as of the Effective Date and ending upon termination of the Agreement.
- 1.2.53 **“Termination Event”** means with respect to any party, the occurrence of any of the following: (i) under the applicable bankruptcy laws or similar law regarding insolvency or relief for debtors, (A) a trustee, receiver, custodian or similar officer is appointed for a party’s business or property, (B) a party seeks to liquidate, wind-up, dissolve, reorganize or otherwise obtain relief from its creditors, or (C) an involuntary proceeding is commenced against a party and the proceeding is not stayed, discharged or dismissed within thirty (30) days of its commencement, or (ii) a party’s Standard and Poor’s issuer credit rating falls to or below BB.
- 1.2.54 **“Time & Attendance Hardware”** means timeclocks and other time collection devices provided to Client by ADP in connection with the ADP Time & Attendance Services.

- 1.2.55 **“Unauthorized Third Party”** means any commercial third party or business that seeks to access or accesses ADP Application Programs using the account credentials (e.g., username and password) of a User even if such User has provided consent.
- 1.2.56 **“USCIS”** means U.S. Citizenship and Immigration Services.
- 1.2.57 **“User”** means any single natural person who, subject to the terms of this Agreement, is an employee or independent contractor of Client authorized by Client to use, access or receive the Services.
- 1.2.58 **“Verification Agent”** means ADP and its subcontractors through which Employment Verification Services are performed.
- 1.2.59 **“Verification Data”** means employment, job and income information and Personal Data.
- 1.2.60 **“Verifiers”** means commercial, private, non-profit and governmental entities and their agents.

## 2 Provision and Use of Services

- 2.1 **Provision of Services.** ADP, or one of its Affiliates, will provide the Services to Client Group in accordance with the terms of this Agreement. ADP will provide the Services in a good, diligent and professional manner in accordance with industry standards, utilizing personnel with a level of skill commensurate with the Services to be performed. ADP’s performance of the Services (including any applicable implementation activities) is dependent upon the timely completion of Client’s responsibilities and obligations under this Agreement.
- 2.2 **Cooperation.** Client will cooperate with ADP as reasonably necessary to implement and provide the Services. Client will, in a timely manner, execute and deliver all necessary documents, forms, or instruments (such as, to the extent applicable, reporting agent authorization, client account agreement, pre-authorized debit terms, limited powers of attorney, anti-money laundering/“Know Your Client” forms), provide ADP with all reasonable and necessary Client Content in the format requested by ADP, and otherwise assist ADP as required.
- 2.3 **Use of Services.** Client will use the Services in accordance with the terms of this Agreement and solely for its own Internal Business Purposes. Client will be responsible for the use of the Services by the Client Group and the Users in accordance with the terms of this Agreement. Client understands and agrees that only Users are permitted to access and use ADP Application Programs (and that access by Unauthorized Third Parties is not permitted) and will reasonably cooperate with ADP to limit access to such persons. Client is responsible for the accuracy and completeness of the Client Content provided to ADP. ADP Workforce Now is designed for the United States and Canada and enables the processing of HR data for global human capital management needs. Client may, at its discretion, enable ADP Workforce Now functionality in other jurisdictions, except when prohibited by applicable law. ADP makes no representation or warranty that such global use comports with any local laws, regulations or directives outside the United States and Canada. Furthermore, if Client during the implementation process or as part of the ongoing Services configures the ADP Application Programs to process additional data elements beyond those data elements that are required by ADP to perform the Services, Client will remain solely responsible for such configurations, including the processing of Personal Data pursuant to applicable law.
- 2.4 **Errors.** Client will promptly review all documents and reports produced by ADP and provided or made available to Client in connection with the Services and promptly notify ADP of any error, omission, or discrepancy with Client’s records. ADP will promptly correct such error, omission or discrepancy and, if such error, omission or discrepancy was caused by ADP, then such correction will be done at no additional charge to Client.
- 2.5 **Records.** Unless expressly included as a part of the Services, and without prejudice to ADP’s obligation to retain the data necessary for the provision of the Services, ADP does not serve as Client’s record keeper and Client will be responsible for retaining copies of all documentation received from or provided to ADP in connection with the Services to the extent required by law or Client’s internal policies.
- 2.6 **Third Party Services Available through or Integrated with the Services.** At times, ADP may make available to Client through the Services, or integrate the Services with, the services of a third party, either through a link, integration, or otherwise. ADP reserves the right to terminate such links, services or integrations at any time for any reason. If Client uses any third party services that are integrated with or linked to the Services which require the transmission, use, sharing, access or exchange of Client Content or any other payroll or other data or information provided to ADP or the third party by Client, Client is expressly agreeing to the transmission, use, sharing, access and exchange of such data between ADP and the third party. Client’s use of any third party services will be governed by any terms Client agrees to with the third party and in the event of any conflict between the terms of this Agreement and any third party terms, the terms of this Agreement will apply to the provision of the Services by ADP to Client.

## 3 Compliance

- 3.1 **Applicable Laws.** Each party will comply with laws and regulations that affect its business generally, including any applicable anti-bribery, export control, computer fraud and data protection laws.
- 3.2 **Design of the Services.** ADP will design the Services, including the functions and processes applicable to ADP’s performance of the Services, to assist the Client in complying with its legal and regulatory requirements applicable to the Services, and ADP will be responsible for the accuracy of such design. Client and not ADP will be responsible for (i) how it uses the Services to comply with its legal and regulatory requirements and (ii) the consequences of any instructions that it gives to ADP, including as part of the implementation of the Services, provided ADP follows such instructions. Services do not include any legal, financial, regulatory, benefits, accounting or tax advice.
- 3.3 **Online Statements.** If Client instructs ADP to provide online pay statements, Forms W2, Forms 1099, or Forms 1095-C without physical copies thereof, Client will be exclusively responsible for determining if and to what extent Client’s use of online pay statements, Forms

W2, Forms 1099, or Forms 1095-C satisfies Client's obligations under applicable laws and the consequences resulting from such determinations.

- 3.4 **Data Privacy Appendix.** ADP's Data Privacy Appendix, located at <https://contracts.adp.com/#data-privacy>, is incorporated by reference into this Agreement.

#### 4 Confidentiality

4.1 **General.** All Confidential Information disclosed under this Agreement will remain the exclusive and confidential property of the disclosing party. The receiving party will not disclose to any third party the Confidential Information of the disclosing party and will use at least the same degree of care, discretion and diligence in protecting the Confidential Information of the disclosing party as it uses with respect to its own confidential information. The receiving party will limit access to Confidential Information to its employees and independent contractors with a need to know the Confidential Information and will instruct those employees and independent contractors to keep such information confidential. ADP may disclose Client's Confidential Information on a need to know basis to (i) ADP's subcontractors who are performing the Services, provided that ADP shall remain liable for any unauthorized disclosure of Client's Confidential Information by those subcontractors, (ii) employees of ADP's Affiliates, provided such employees are instructed to keep the information confidential as set forth in this Agreement and (iii) social security agencies, tax authorities and similar third parties, to the extent strictly necessary to perform the Services. ADP may use Client's and its employees' and other Services recipients' information in an aggregated, anonymized form, such that neither Client nor such person may be identified, and Client will have no ownership interest in such aggregated, anonymized data. Client authorizes ADP to release employee-related data, and such other data as required to perform the Services, to third party vendors of Client as designated by Client from time to time. Notwithstanding the foregoing, the receiving party may disclose Confidential Information (x) to the extent necessary to comply with any law, rule, regulation or ruling applicable to it, (y) as appropriate to respond to any summons or subpoena or in connection with any litigation and (z) to the extent necessary to enforce its rights under this Agreement.

4.2 **Return or Destruction.** Upon the request of the disclosing party or upon the expiration or earlier termination of this Agreement, and to the extent feasible, the receiving party will return or destroy all Confidential Information of the disclosing party in the possession of the receiving party, provided that each party may maintain a copy if required to meet its legal or regulatory obligations and may maintain archival copies stored in accordance with regular computer back-up operations. To the extent that any portion of Confidential Information of a disclosing party remains in the possession of the receiving party following expiration or earlier termination of this Agreement, such Confidential Information shall remain subject to the generally applicable statutory requirements and the confidentiality protections contained in Section 4.1.

#### 5 Intellectual Property

5.1 **Client IP Rights.** Except for the rights expressly granted to ADP in this Agreement, all rights, title and interests in and to Client Content, including all Intellectual Property Rights inherent therein and pertaining thereto, are owned exclusively by Client or its licensors. Client hereby grants to ADP for the Term a non-exclusive, worldwide, non-transferable, royalty-free license to use, edit, modify, adapt, translate, exhibit, publish, reproduce, copy and display the Client Content for the sole purpose of performing the Services; provided Client has the right to pre-approve the use by ADP of any Client trademarks or service marks.

5.2 **ADP IP Rights.** Except for the rights expressly granted to Client in this Agreement, all rights, title and interest in and to the Services, including all Intellectual Property Rights inherent therein and pertaining thereto, are owned exclusively by ADP or its licensors. ADP grants to Client for the Term a personal, non-exclusive, non-transferable, royalty-free license to use and access the ADP Application Programs solely for the Internal Business Purposes in the United States and Canada and solely up to the maximum number of Users (if any) indicated in the Sales Order. The ADP Application Programs do not include any Client-specific customizations unless otherwise agreed in writing by the parties. Client will not obscure, alter or remove any copyright, trademark, service mark or proprietary rights notices on any materials provided by ADP in connection with the Services, and will not copy, recompile, disassemble, reverse engineer, or make or distribute any other form of, or any derivative work from, such ADP materials.

5.3 **Ownership of Reports.** Client will retain ownership of the content of reports and other materials that include Client Content produced and delivered by ADP as a part of the Services, provided that ADP will be the owner of the format of such reports. To the extent any such reports or other materials incorporate any ADP proprietary information, ADP (i) retains sole ownership of such proprietary information and (ii) provides the Client a fully paid up, irrevocable, perpetual, royalty-free license to access and use same for its Internal Business Purposes without the right to create derivative works (other than derivative works to be used solely for its Internal Business Purposes) or to further distribute any of the foregoing rights outside the Client Group.

5.4 **Improvements.** ADP will make available to Client, at no additional cost, software improvements, enhancements, or updates to any ADP Application Programs that are included in the Services (collectively "Improvements") if and as they are made generally available by ADP at no additional cost to ADP's other clients using the same ADP Application Programs as Client and receiving the same Services as Client. All Improvements provided under this Section 5.4 shall be considered part of the ADP Application Programs. If Client fails to implement Improvements provided or made available to Client by ADP, ADP shall be relieved of any responsibility for errors or degradation in the Services and shall have no obligation to provide support for the ADP Application Programs.

#### 6 Indemnities

6.1 **ADP Indemnity.** Subject to the remainder of this Section 6.1, and Sections 6.3 and 7, ADP will defend Client against any third party claims and will indemnify and hold Client harmless from any resulting damage awards or settlement amounts in any cause of action to the extent such cause of action is based on a claim alleging that the Services or ADP Application Programs, as provided by ADP and used in accordance with the terms of this Agreement, infringe upon any Intellectual Property Rights of a third party in the United States. The foregoing infringement indemnity will not apply and ADP will not be liable for any damages assessed in any cause of action to the extent resulting from a Client Infringement Event or ADP's use of Client Content as contemplated by this Agreement. If any Service is held or believed to infringe on any third-party's Intellectual Property Rights, ADP may, in its sole discretion, (i) modify the

Service to be non-infringing, (ii) obtain a license to continue using such Service, or (iii) if neither (i) nor (ii) are practical, terminate this Agreement as to the infringing Service and return to Client any unearned fees prepaid by Client to ADP.

**6.2 Client Indemnity.** Subject to Sections 6.3 and 7, Client will defend ADP against any third party claims and will indemnify and hold ADP harmless from any resulting damage awards or settlement amounts in any cause of action to the extent such cause of action is based on the occurrence of a Client Infringement Event or ADP's use of Client Content as contemplated by this Agreement.

**6.3 Indemnity Conditions.** The indemnities set forth in this Agreement are conditioned on the following: (i) the party claiming indemnification (the "Indemnitee") shall promptly notify the indemnifying party (the "Indemnitor") of any matters in respect of which it seeks to be indemnified, and shall give the Indemnitor full cooperation and opportunity to control the response thereto and the defense thereof, including without limitation any settlement thereof, (ii) the Indemnitor shall have no obligation for any claim under this Agreement if the Indemnitee makes any admission, settlement or other communication regarding such claim without the prior written consent of the Indemnitor, which consent shall not be unreasonably withheld, and (iii) the Indemnitee's failure to promptly give notice to the Indemnitor shall affect the Indemnitor's obligation to indemnify the Indemnitee only to the extent the Indemnitor's rights are materially prejudiced by such failure. The Indemnitee may participate, at its own expense, in such defense and in any settlement discussions directly or through counsel of its choice.

## 7 Limit on Liability

**7.1 Ordinary Cap.** Notwithstanding anything to the contrary in this Agreement and subject to the remainder of this Section 7, neither party's aggregate liability in any calendar year shall exceed an amount equal to six (6) times the average ongoing monthly Services fees paid or payable to ADP by Client during such calendar year for all Services (the "Ordinary Cap").

**7.2 Extraordinary Cap.** As an exception to Section 7.1, if damages arise from a breach of Section 4 (Confidentiality), Section 9.3 (Data Security) or Section 9.4 (Unauthorized Third Party Access), the Ordinary Cap will be increased by an additional six (6) times the average ongoing monthly Services fees paid or payable to ADP by Client during such calendar year for all Services (the "Extraordinary Cap"). For the avoidance of doubt, in no case shall either party's aggregate liability in any calendar year under this Agreement exceed an amount equal to twelve (12) times the average monthly ongoing Services fees paid or payable to ADP by Client during such calendar year for all Services.

**7.3 Matters not Subject to the Cap.** The foregoing limits on liability shall not apply to the following:

**7.3.1** Client's funding obligations in connection with the Payment Services;

**7.3.2** Loss or misdirection of Client funds in possession or control of ADP due to ADP's error or omission;

**7.3.3** In connection with the ADP Employment Tax Services, (i) interest charges imposed by an applicable tax authority on Client for the failure by ADP to pay funds to the extent and for the period that such funds were held by ADP and (ii) all tax penalties resulting from ADP's error or omission in the performance of such Service. The provisions of this Section 7.3.3 shall only apply if (x) Client permits ADP to act on Client's behalf in any communications and negotiations with the applicable taxing authority that is seeking to impose any such penalties or interest and (y) Client assists ADP as reasonably required by ADP;

**7.3.4** Either party's gross negligence, or willful, criminal or fraudulent misconduct;

**7.3.5** The infringement indemnity set forth in Section 6.1 and 6.2;

**7.3.6** Client's biometrics indemnity set forth in Section 14;

**7.3.7** Client's obligations to pay the fees for Services; and

**7.3.8** ADP's obligations to provide credit monitoring as set forth in Section 10.2.

**7.4 Mitigation of Damages.** ADP and Client will each use reasonable efforts to mitigate any potential damages or other adverse consequences arising from or related to the Services.

**7.5 No Consequential Damages.** NOTWITHSTANDING ANYTHING TO THE CONTRARY IN THIS AGREEMENT AND ONLY TO THE EXTENT PERMITTED BY APPLICABLE LAW, NONE OF ADP, CLIENT OR ANY ISSUING BANK WILL BE RESPONSIBLE FOR SPECIAL, INDIRECT, INCIDENTAL, CONSEQUENTIAL OR OTHER SIMILAR DAMAGES (INCLUDING DAMAGES FOR LOSS OF BUSINESS OR PROFITS, BUSINESS INTERRUPTIONS OR HARM TO REPUTATION) THAT ANY OTHER PARTY OR ITS RESPECTIVE AFFILIATES MAY INCUR OR EXPERIENCE IN CONNECTION WITH THIS AGREEMENT OR THE SERVICES, HOWEVER CAUSED AND UNDER WHATEVER THEORY OF LIABILITY, EVEN IF SUCH PARTY HAS BEEN ADVISED OF THE POSSIBILITY OF SUCH DAMAGES. The foregoing exclusion shall not apply to claims for consequential damages arising from (i) ADP's or Client's gross negligence or willful, criminal or fraudulent misconduct, (ii) Client or Client's Users sharing or allowing access to a User's password, User ID, or other form of user authentication, or (iii) ADP's or Client's breach or breaches of Section 4.1 or Section 9.3 under this Agreement; provided however, that any consequential damages recovered by Client or ADP in a calendar year for claims pursuant to Sections 7.5(ii) and 7.5(iii) will be subject to the Extraordinary Cap set forth in Section 7.2 above.

## 8 Warranties and Disclaimer

**8.1 Warranties.** Each party warrants that (i) it has full corporate power and authority to execute and deliver this Agreement and to consummate the transactions contemplated hereby and (ii) this Agreement has been duly and validly executed and delivered and constitutes the valid and binding agreement of the parties, enforceable in accordance with its terms.

**8.2 DISCLAIMER.** EXCEPT AS EXPRESSLY SET FORTH IN THIS AGREEMENT, ALL SERVICES, ADP APPLICATION PROGRAMS AND EQUIPMENT PROVIDED BY ADP OR ITS SUPPLIERS ARE PROVIDED "AS IS" AND ADP AND ITS LICENSORS AND

SUPPLIERS EXPRESSLY DISCLAIM ANY WARRANTY, EITHER EXPRESS OR IMPLIED, INCLUDING WITHOUT LIMITATION, ANY IMPLIED WARRANTIES OF MERCHANTABILITY OR FITNESS FOR A PARTICULAR PURPOSE, NON-INFRINGEMENT, NON-INTERRUPTION OF USE, AND FREEDOM FROM PROGRAM ERRORS, VIRUSES OR ANY OTHER MALICIOUS CODE, WITH RESPECT TO THE SERVICES, THE ADP APPLICATION PROGRAMS, ANY CUSTOM PROGRAMS CREATED BY ADP OR ANY THIRD-PARTY SOFTWARE DELIVERED BY ADP AND RESULTS OBTAINED THROUGH THE USE THEREOF.

## 9 Security and Controls

- 9.1 Service Organization Control Reports.** Following completion of implementation of any applicable Services, ADP will, at Client's request and at no charge, provide Client with copies of any routine Service Organization Control 1 reports ("**SOC 1 Reports**") (or any successor reports thereto) that are both directly related to those Services provided hereunder for Client and already released to ADP by the public accounting firm producing the report. SOC 1 Reports are ADP Confidential Information and Client will not distribute or allow any third party (other than its independent auditors) to use any such report without the prior written consent of ADP. Client will instruct its independent auditors or other approved third parties to keep such report confidential and Client will remain liable for any unauthorized disclosure of such report by its independent auditors or other approved third parties.
- 9.2 Business Continuity; Disaster Recovery.** ADP maintains a commercially reasonable business continuity and disaster recovery plan and will follow such plan.
- 9.3 Data Security.** ADP has an established information security program containing appropriate administrative, technical and physical measures to protect Client data (including Personal Data) against accidental unlawful or unauthorized destruction, alteration, unauthorized disclosure or access consistent with applicable laws. In the event ADP suspects any unauthorized access to, or use of, the Services and ADP Application Programs, ADP may suspend access to the Services to the extent ADP deems necessary to preserve the security of ADP, Client or User data.
- 9.4 Unauthorized Third Party Access.** Client and its Users are responsible for maintaining the security and confidentiality of any password, User ID, or other form of user authentication involved in obtaining access to ADP Application Programs, and Client and its Users shall not disclose any confidential account access credentials or related information to Unauthorized Third Parties.

## 10 Data Security Breach

- 10.1 Notification.** If ADP becomes aware of a Data Security Breach of Client's Personal Data, ADP will take appropriate actions to contain, investigate and mitigate the Data Security Breach. ADP shall notify Client without undue delay after becoming aware that a Data Security Breach has occurred, unless otherwise required or instructed by law enforcement or regulatory authority. ADP will share information in its possession with Client for Client to determine any regulatory reporting obligations required by applicable law.
- 10.2 Other ADP Obligations.** In the event that a Data Security Breach is the result of the failure of ADP to comply with the terms of this Agreement, ADP shall, to the extent legally required or otherwise necessary to notify the individuals of potential harm, bear the actual, reasonable costs of notifying affected individuals. ADP and Client shall mutually agree on the content and timing of any such notifications, in good faith and as needed to meet applicable legal requirements. In addition, where notifications are required, and where such monitoring is practicable and customary, ADP shall also bear the cost of one year of credit monitoring to affected individuals in the applicable jurisdictions.

## 11 Payment Terms

- 11.1 Fees and Fee Adjustments.** Client shall pay to ADP the fees and other charges for the Services as set forth in the Sales Order. The recurring Services fees (excluding delivery, tax and banking (including reverse wire), jurisdiction, year-end and maintenance fees) will remain fixed during the first six (6) months following the Effective Date, and thereafter ADP may modify the fees on an annual basis upon thirty (30) days' prior written notice to Client. The fees presented in any Sales Order were calculated based upon particular assumptions relative to Client requirements (including funding requirements), specifications, volumes and quantities as reflected in the applicable Sales Order and related documentation, and if Client's actual requirements vary from what is stated, ADP may adjust the fees based on such changes. The fees do not include any customizations to any Service.
- 11.1.1 Twelve Month Promo.** Subject to the conditions herein, Client will receive (the "**Promo**") twelve (12) months of free Workforce Now Services listed in Sales Order Quote Number 02-2026-108079 3 (the "**Promotional Services**"), during which months no recurring Services fees will be charged for such Promotional Services, provided that the Promo will only apply to months 7 – 10 in Year 1, months 19 – 22 in Year 2, and months 31 – 34 in Year 3 from the billing start date of each applicable Promotional Service set forth in Sales Order Quote Number 02-2026-108079 3. The free months will apply to the monthly recurring Services fees for the Promotional Services only. The Promo excludes delivery, tax and banking (including reverse wire), jurisdiction, maintenance and/or implementation fees, professional services fees and any year-end fees (e.g., for W-2s). The monthly Promo value may vary. Services purchased before or after the Addendum Effective Date are not eligible for the Promo. In order for Client to receive such free months, Client's account must be active and in good standing.
- 11.2 Additional Services and Charges.** Any Services provided to Client but not included in a Sales Order will be provided subject to the terms of this Agreement and charged at the applicable rates as they occur; and those services will be considered to be "Services" for purposes of this Agreement. Additional charges may be assessed to Client in relation to the performance of the Services in certain circumstances, including without limitation, late funding, an insufficient funds notification and emergency payment requests from Client.
- 11.3 Fees for Implementation Services.** Implementation fees are due and payable by Client upon the Go-Live Date for such Services. However, if (i) this Agreement or any Service is terminated after Implementation Services have started but before the applicable Go-Live Date or (ii) Client fails to reasonably cooperate with ADP in connection with the Implementation Services such that ADP is unable to complete such Implementation Services, then ADP may terminate this Agreement or any Service upon written notice to Client and, in each case, thirty percent (30%) of the total non-discounted implementation fees set forth in the Sales Order shall be immediately due and payable by Client.

- 11.4 Invoicing.** ADP will notify Client of all applicable Services fees payable by Client by way of invoice or other method (i.e. ADP's on-line reporting tool). Client will pay the amount on each invoice or such other similar document in full pursuant to the agreed upon method of payment set forth in the Sales Order. All amounts not paid when due are subject to a late payment charge of one and one-half percent (1.5%) per month (not to exceed the maximum allowed by applicable law) of the past due amount from the due date until the date paid.
- 11.5 Currency.** Client shall pay the fees in US dollars.
- 11.6 Taxes.** Unless Client provides ADP a valid tax exemption or direct pay certificate, Client will pay directly, or will pay to ADP, an amount equal to all applicable taxes or similar fees levied or based on the Agreement or the Services, exclusive of taxes based on ADP's net income.
- 11.7 Postage, Shipping, Travel and Out-of-Pocket Expenses.** ADP will invoice Client for postage charges, delivery charges, other third party charges, reasonable preapproved travel expenses, and travel-related out-of-pocket expenses, as necessary to provide the Services.
- 11.8 Funding Requirements and Disbursement Disclosures.** With respect to Payment Services to be deducted by ACH or Pre-Authorized Debit, Client must have sufficient good funds for payment of the payroll obligations, tax filing obligations, wage garnishment deduction obligations, service fees (as applicable), expenses, and any other applicable charges, to be direct debited from Client's designated account no later than one (1) Business Day prior to the pay date for the applicable payroll (in the case of payroll processing services), or as otherwise agreed by the parties. For reverse wire clients, funds must be available (a) by 6:00 a.m. Pacific time on the Business Day immediately before the associated payroll check date (in the case of the ADP Employment Tax Services) and (b) by 6:00 a.m. Pacific time two (2) Business Days prior to the associated payroll check date for all other Payment Services. In consideration for the additional costs incurred by ADP in providing wire transfer service, Client agrees to pay a reasonable fee for each wire transfer. Notwithstanding the foregoing, ADP reserves the right to modify the aforementioned deadlines at any time and will communicate any such modifications to Client.
- 11.9 Change Control.** In the event either party requests a change in the scope of Services (including implementation services) or any rework is required by ADP as a result of a delay by Client in implementation of any Services (each a "Change Control Item"), the parties shall address such change request, if possible via ADP's change control process. Change Control Items and the cost associated with such changes (if any) to the Services shall be mutually agreed to by the parties and shall be defined in a statement of work agreed to by the parties, with the exceptions of Change Control Items that are required to be made by law or regulation applicable to the Services or to the duration of implementation services, which ADP will notify Client of prior to making the change.

## 12 Term; Termination; Suspension

- 12.1 Term; Termination for Convenience.** This Agreement will commence on the Effective Date and remain in effect until terminated by either party in accordance with the terms hereof. Either party may terminate this Agreement or any Service upon sixty (60) days' prior written notice to the other party (except as otherwise set forth in this Section 12).
- 12.2 Termination for Cause.** Either party may terminate this Agreement for the other's material breach of this Agreement if such breach is not cured within sixty (60) days following notice thereof or in the event either party is the subject of a Termination Event. In addition, ADP may terminate this Agreement in the event Client fails to timely pay fees for Services performed within ten (10) days following notice that such fees are past due. ADP may also terminate this Agreement or the Services immediately on written notice to Client if the provision of Service to Client causes or will cause ADP or its Affiliates to be in violation of any laws, rules or regulations applicable to it including any sanction laws applicable to ADP or any Affiliate.
- 12.3 Suspension.** Without limiting the foregoing, the parties agree that Payment Services involve credit risk to ADP. Payment Services may be suspended by ADP (A) immediately following notice to Client (i) that Client has failed to remit sufficient, good and available funds within the deadline and via the method of delivery agreed upon as it relates to the applicable Payment Services, or (ii) if Client breaches any rules promulgated by the NACHA (or other similar local regulator) as it relates to ADP conducting ACH (or similar electronic payment) transactions on behalf of Client, and (B) with 24 hour notice if: (i) a bank notifies ADP that it is no longer willing to originate debits from Client's account(s) or credits for Client's behalf for any reason or (ii) the authorization to debit Client's account is terminated or ADP reasonably believes that there is or has been fraudulent activity on the account. If the Payment Services are terminated or suspended pursuant to Sections 12.2 or 12.3, Client acknowledges that ADP shall be entitled to allocate any funds in ADP's possession that have been previously remitted or otherwise made available by Client to ADP relative to the Payment Services in such priorities as ADP may determine appropriate, including reimbursing ADP for payments made by ADP on Client's behalf to a third party. If the Payment Services are terminated by ADP, Client understands that it will (x) immediately become solely responsible for all of Client's third party payment obligations covered by the Payment Services then or thereafter due (including, without limitation, for ADP Employment Tax Services, any and all penalties and interest accruing after the date of such termination, other than penalties and interest for which ADP is responsible under Section 7.3.3), and (y) reimburse ADP for all payments properly made by ADP on behalf of Client to any Payee, which has not been paid or reimbursed by Client. If the Payment Services remains suspended for 30 days, the affected Payment Service shall be deemed terminated on the 31st day following suspension.
- 12.4 Additional Termination Provisions.**
- 12.4.1 Additional Termination Provisions for ADP Employment Tax Services.** If the ADP Employment Tax Services in the United States are terminated, Client's access to ADP websites containing Client's data will expire 90 days from the effective date of the termination, and Client will be responsible for downloading all relevant data, including Statements of Deposit (SODs) prior to the expiration of such access.
- 12.4.2 Additional Termination Provisions for Employment Verification Services.** ADP may, in its sole discretion, terminate the Employment Verification Services at any time upon 90 days prior written notice to Client should a Verification Agent notify ADP

that it is no longer willing to provide the Employment Verification Services and ADP, after taking commercially reasonable steps, cannot engage a successor Verification Agent.

- 12.4.3 **Additional Termination Provisions for ADP Time & Attendance Services.** If ADP determines that Client has failed to comply with any potentially applicable laws and regulations applicable to the Biometric Services, ADP may, in its sole discretion and upon notice to Client, immediately suspend or terminate the Biometric Services.
- 12.4.4 **Additional Termination Provisions for Essential ACA Services.** If ADP reasonably determines that it can no longer provide all or any portion of Essential ACA Services due to changes in applicable law or application of existing law, ADP may, in its sole discretion and upon notice to Client, immediately terminate the applicable portion of Essential ACA Services.
- 12.4.5 **Additional Termination Provision for ADP Workforce Now IT Management, Powered by Electric.** Client's access to ADP Workforce Now IT Management, Powered by Electric may terminate if (i) Human Resources Administration Services are terminated, (ii) the agreement between ADP and Electric AI, Inc. terminates or otherwise expires or (iii) the agreement between Client and Electric AI, Inc. terminates or otherwise expires.
- 12.4.6 **Additional Suspension Provision for ADP Connect Services.** ADP may, in its sole discretion, immediately suspend access to ADP Connect Services without prior notice to Client in the event Client or Client's Users post or otherwise distribute any Objectionable Content. In the event Client or Client's Users continue to post or distribute such content after access to the ADP Connect Services is restored, ADP shall have the right to terminate ADP Connect Services.

### 13 Post Termination

- 13.1 **Scope.** At any time prior to the termination of Client's access to the ADP Application Programs, Client may download Client's information or reports available to it in conjunction with all of the Services provided to Client by ADP. Under no circumstances will ADP be required to provide any third party with access to the ADP Application Programs, ADP's intellectual property or any Confidential Information of ADP.
- 13.2 **Past Due Amounts.** If ADP has terminated this Agreement due to Client's failure to pay fees, ADP's obligations in Section 13.1 will be subject to Client's payment of all past due amounts and ADP may require Client to prepay for any services.

### 14 Additional Terms

- 14.1 **ADP Employment Tax Services.** The following additional terms and conditions apply to the ADP Employment Tax Services:
  - 14.1.1 **Important Tax Information (IRS Disclosure) for U.S. Only.** Notwithstanding Client's engagement of ADP to provide the ADP Employment Tax Services in the United States, please be aware that Client remains responsible for the timely filing of payroll tax returns and the timely payment of payroll taxes for its employees. The Internal Revenue Service recommends that employers enroll in the U.S. Treasury Department's Electronic Federal Tax Payment System (EFTPS) to monitor their accounts and ensure that timely tax payments are being made for them, and that online enrollment in EFTPS is available at [www.eftps.gov](http://www.eftps.gov); an enrollment form may also be obtained by calling (800) 555-4477; that state tax authorities generally offer similar means to verify tax payments; and that Client may contact appropriate state offices directly for details.
- 14.2 **Benefit Services.** The following additional terms and conditions apply to the Benefit Services:
  - 14.2.1 **Benefits Liaison.** Client shall designate in writing to ADP one or more contacts for the Benefit Services to serve as the Client Benefits Liaison, and such Client Benefits Liaison shall have the authority to (i) provide information, instructions and direction on behalf of the Client, each Plan Administrator and, if applicable, each "fiduciary" (as defined in Section 3(21) of ERISA) of each separate Plan, and (ii) grant or provide approvals (other than Amendments) required or permitted under the Agreement in connection with the Benefit Services.
  - 14.2.2 **Compliance of Benefit Plans.** Client shall furnish to ADP all necessary information and data for each Plan. Client shall be responsible for the final preparation, approval and submission of Plans and related amendments to applicable governmental authorities. Client is responsible for, and shall take measures required under state and federal law to assure the qualification and compliance of the Plans with such laws.
  - 14.2.3 **Disclaimer.** NOTWITHSTANDING ANYTHING TO THE CONTRARY CONTAINED HEREIN OR IN THE SCOPE OF SERVICES, CLIENT EXPRESSLY ACKNOWLEDGES THAT ADP IS NOT THE "ADMINISTRATOR" OR "PLAN ADMINISTRATOR" AS DEFINED IN SECTION 3(16)(A) OF ERISA AND SECTION 414(g) OF THE INTERNAL REVENUE CODE OF 1986, AS AMENDED, RESPECTIVELY, NOR IS ADP A "FIDUCIARY" WITHIN THE MEANING OF ERISA SECTION 3(21), NOR IS ADP A "HEALTH CARE CLEARINGHOUSE" WITHIN THE MEANING OF SECTION 1171 OF THE HEALTH INSURANCE PORTABILITY AND ACCOUNTABILITY ACT OF 1996, AS AMENDED ("HIPAA") AND CLIENT SHALL NOT REQUEST OR OTHERWISE REQUIRE ADP TO ACT AS SUCH. FURTHER, ADP DOES NOT PROVIDE CLAIMS PROCESSING OR ANY OTHER COVERED FUNCTION WHICH WOULD CAUSE ADP TO BE CONSIDERED A BUSINESS ASSOCIATE AS DEFINED AT 45 CFR §160.103. ALL ENROLLMENT INFORMATION AND RELATED DATA COLLECTED BY ADP IS ON BEHALF OF CLIENT AND NOT ANY EMPLOYER-SPONSORED BENEFIT PLAN. ALL OTHER INFORMATION COLLECTED BY ADP FOR PROVIDING BENEFITS SERVICES IS CONSIDERED EMPLOYMENT RECORDS AND EXPLICITLY EXCLUDED FROM THE DEFINITION OF PROTECTED HEALTH INFORMATION AS STATED AT 45 CFR §160.103, AND IS NOT PROTECTED BY HIPAA'S PRIVACY RULE. SEE ALSO IDENTIFIABLE HEALTH INFORMATION: FINAL RULE, 67 FED. REG. 53,182, 53,192 (Aug. 14, 2002). ADP SHALL NOT EXERCISE ANY DISCRETIONARY AUTHORITY OR DISCRETIONARY CONTROL REGARDING MANAGEMENT OF ANY PLAN OR MANAGEMENT OR DISPOSITION OF ANY PLAN ASSETS. ADP SHALL NOT RENDER INVESTMENT ADVICE FOR A FEE OR OTHER COMPENSATION, DIRECT OR INDIRECT, WITH RESPECT TO ANY MONIES OR OTHER PROPERTY OF ANY PLAN, NOR DOES ADP HAVE ANY AUTHORITY OR RESPONSIBILITY TO DO SO. ADP HAS NO DISCRETIONARY AUTHORITY OR DISCRETIONARY RESPONSIBILITY IN THE ADMINISTRATION OF THE PLAN(S).

- 14.2.4 Carrier Connections.** ADP will, at Client's request, and for an additional charge as set forth on the Sales Order, provide Client with the following Carrier Connections services:
- 14.2.4.1** ADP will electronically transmit employee data, including employee benefits enrollment data, to Client's carriers or other third parties authorized by Client, and Client authorizes ADP to provide such transmission on Client's behalf. Commencement of carrier connection service is subject to Client completing the configuration setup of Client Content and the format for such transmission to the designated carriers.
  - 14.2.4.2** ADP's ability to transmit Client Content data is subject to the provision by Client's designated carriers of a current functional interface between ADP's systems and the designated carriers' systems. ADP will not be obligated to transmit Client's data to designated carriers if at any time Client's designated carriers fail to provide the proper interface as described above. Client is responsible for promptly reviewing all records of carrier transmissions and other reports prepared by ADP for validity and accuracy according to Client's records, and Client will notify ADP of any discrepancies promptly after receipt thereof. In the event of an error or omission in carrier connection services caused by ADP, ADP will correct such error or omission, provided that Client promptly advises ADP of such error or omission.
- 14.2.5 Additional Third-Party Terms.** During the Term of this Agreement, the Client's use of, and access to, the Benefit Services may be subject to additional terms of service which shall be included within the Benefit Services. Prior to enabling such Services, Client shall ensure that its Users of Benefit Services click through and accept such additional terms of service.
- 14.2.6 Technology Credit Program.** ADP has a Technology Credit Program to accept technology credits from Strategic Carrier Partners and apply those funds to Client invoices for ADP benefits administration services, subject to the following additional terms:
- 14.2.6.1** As between Client and ADP, Client is solely responsible for (i) Client's acceptance of the Technology Credit; and directing ADP to apply such Technology Credit to offset Client's benefits administration Services fees; (ii) the determination whether the Technology Credit is a Plan Asset and the consequences resulting from such determination; and (iii) any compliance obligations that may arise under ERISA or other applicable laws as a result of Client's acceptance of the Technology Credit.
  - 14.2.6.2** If Client elects to accept a Technology Credit, Client will instruct ADP how to apply such Technology Credit. ADP will verify all information provided by Client regarding the Technology Credit with the applicable Strategic Carrier Partner. Per Client direction, ADP will apply the Technology Credit to Client's invoice for benefits administration services fees no earlier than sixty (60) days following ADP's receipt of the Technology Credit from the Strategic Carrier Partner.
  - 14.2.6.3** Client shall remain responsible for payment of the fees for the Services in accordance with the Agreement if the Strategic Carrier Partner fails to remit sufficient, good and available funds to ADP.
  - 14.2.6.4** To the extent Client adds a Strategic Carrier Partner's benefits plan to Client's ADP Workforce Now benefits module, Client consents to ADP working with such carrier with respect to the Services, including sharing with such carrier that Client offers a benefits plan provided by such carrier.
- 14.3 WFN EI-9 Services.** The following additional terms and conditions apply to the WFN EI-9 Services.
- 14.3.1 Use of Services.** Client shall, and cause the members of the Client Group, receiving the WFN EI-9 Services to do the following:
    - 14.3.1.1** Review the USCIS Form I-9, which is the employment eligibility verification form issued by the DHS, including instructions in the form and the guidelines in the current I-9 Handbook, each of which is available on the USCIS website, currently located at <http://www.uscis.gov/i-9central>. Client certifies that it has reviewed the current USCIS Form I-9 and the I-9 Handbook and that it agrees to comply with the applicable policy and procedures set forth therein, and any future new or amended policies or procedures, as required by law. Client will ensure availability of the most recent version of the USCIS Form I-9 and the I-9 Handbook to all employees authorized to complete the USCIS Form I-9 on behalf of Client and/or its Affiliates.
    - 14.3.1.2** Client is responsible for reviewing reports available to Client on the WFN EI-9 Services and for resolving (or causing the applicable employee to take action to resolve) missing or incomplete Forms I-9. This includes communicating with the employee in question and the submission or resubmission of the missing or incomplete Form I-9.
    - 14.3.1.3** ADP executed a Memorandum of Understanding with the DHS as the E-Verify employer agent. E-Verify is the DHS's employment eligibility verification program which allows participating employers to electronically verify the employment eligibility of each newly hired employee and/or employee assigned to a covered federal contract. The following is required as it relates to the use of E-Verify through ADP and will apply only to the extent Client is using E-Verify through ADP
      - 14.3.1.3.1** Notify ADP of (i) the location(s) where Client elects to enroll; and (ii) whether the employer is a federal contractor or a federal, state or local government organization.
      - 14.3.1.3.2** Execute a Memorandum of Understanding with the DHS and ADP (as its E-Verify employer agent), and comply with the terms and conditions set forth therein.



**14.6.2 Biometric Services.** Biometric Services are optional. In certain jurisdictions, there are laws and regulations that govern the collection, use, and retention of biometric information, which potentially may apply to Client's use of Biometric Services. To the extent Client elects to use Biometric Services, Client agrees to comply with all such potentially applicable laws and regulations in accordance with this section. In the event Client is unwilling to comply with laws and regulations potentially applicable to Biometric Services, Client will be able to continue to use ADP Time & Attendance Services without Biometric Services. The following terms and conditions apply to Biometric Services to the extent Biometric Services are part of the scope of Services:

**14.6.2.1 Requirements for Receipt of Biometric Services.** Before any Client or Biometric User is permitted to use any Biometric Services in a jurisdiction where laws and regulations potentially govern such use, Client will comply with the following requirements, in addition to any other requirements imposed by potentially applicable law (to the extent there is a conflict between the requirements below and the requirements of potentially applicable law, Client will comply with potentially applicable law):

**14.6.2.1.1 Client Biometric Information Policy.** Client will implement, distribute and make available to the public, a written policy establishing Client's policy with respect to the use of Biometric Data. Such policy will include:

**14.6.2.1.1.1** a retention schedule and guidelines for permanently destroying Biometric Data;

**14.6.2.1.1.2** a commitment to destroy Biometric Data when the initial purpose for collecting or obtaining such Biometric Data has been satisfied or within 3 years of the individual's last interaction with Client, whichever occurs first; and

**14.6.2.1.1.3** any additional requirements as required by potentially applicable law.

**14.6.2.1.2 Biometric User Notice and Consent.** Client will provide notice to and procure and retain appropriate consents or releases from Biometric Users in the manner and to extent the same are required by potentially applicable law, including:

**14.6.2.1.2.1** notifying Biometric Users in writing that Client and/or its vendors are collecting, capturing, or otherwise obtaining Biometric Users' Biometric Data, and that Client is providing such Biometric Data to its vendors; such notice will specify the purpose and length of time for which Biometric User's Biometric Data is being collected, stored, and used;

**14.6.2.1.2.2** obtaining a written release or consent from Biometric Users (or their legally authorized representative) authorizing Client and/or its vendors to collect, store, and use the individual's Biometric Data for the specific purpose disclosed by Client, and authorizing Client to provide such Biometric Data to its vendors; and

**14.6.2.1.2.3** if requested by ADP, providing to ADP copies of the required consents or releases collected and retained by Client, and/or certifying to ADP that such consents or releases have been obtained.

**14.6.2.1.3 Retention and Purging of Biometric Data.** Client will work with ADP to ensure that Biometric Data is retained and purged in accordance with potentially applicable law. To the extent necessary for the purging or deletion of such Biometric Data, Client agrees to provide timely notification to ADP of the termination of the employment, or the satisfaction of the purpose for which Biometric Data was collected with respect to any given Biometric User. ADP is not responsible for Client's failure to provide timely notification of the termination of the employment, or the satisfaction of the purpose for which Biometric Data was collected with respect to any given Biometric User.

**14.6.2.1.4 Storage of Biometric Data in Timeclocks.** Client agrees that it shall use a reasonable standard of care consistent with potentially applicable law to store, transmit and protect from disclosure any Biometric Data. Such storage, transmission, and protection from disclosure shall be performed in a manner that is the same as or more protective than the manner in which Client stores, transmits and protects from disclosure other confidential and sensitive information, including personal information that can be used to uniquely identify an individual or an individual's account or property, such as genetic markers, genetic testing information, account numbers, PINs, driver's license numbers and social security numbers.

**14.6.2.2 Biometrics Indemnity.** Subject to Sections 6.3 and 7, Client will defend ADP against any third party claims (including claims made by or on behalf of Biometric Users) and will indemnify and hold ADP harmless from resulting damage awards or settlement amounts in any cause of action to the extent such cause of action is based on any performance or breach of Client's obligations in connection with the Biometric Services, including any failure by Client to obtain consent from Biometric Users in connection with the use of the Biometric Services.

**14.7 Tax Registration Services.** ADP shall provide tax registration services as further described in this Section (the "Tax Registration Services") in accordance with and subject to the terms of this Agreement. The Tax Registration Services provided hereunder relate solely to ADP obtaining jurisdiction account numbers for employment tax as requested by Client. In receiving the Tax Registration Services hereunder, Client acknowledges the following:

- 14.7.1** Client understands that ADP will not perform Tax Registration Services in connection with the following events: (i) mergers and acquisitions; (ii) name, address or entity (corporate form) changes; (iii) applications to a state's Secretary of State; and (iv) closing of accounts with a state taxing agency.
- 14.7.2** As a third-party service provider, ADP's Services hereunder are consultative in nature. ADP is not representing Client in any dealings before any tax agencies. ADP's provision of the Tax Registration Services should not be construed as legal, tax, or accounting advice. Client should consult its legal, tax, or accounting advisors for such advice.
- 14.7.3** All submissions to the taxing jurisdiction will be (i) reviewed by Client prior to submission, when provided and (ii) signed by Client where necessary or Client will instruct ADP to affix electronically the Client signature provided by Client. By signing the documents or requesting that ADP affix Client's electronic signature, Client is confirming that (i) Client has reviewed the documents and/or data being submitted to the taxing jurisdiction and (ii) the information contained therein is complete and accurate.
- 14.7.4** By utilizing the Tax Registration Services, Client authorizes ADP to act on its behalf in obtaining jurisdiction employment tax account numbers including, but not limited to, affixing the electronic signature provided by Client to registration forms and other documentation, submitting forms to tax agencies and directly communicating with such agencies as necessary.
- 14.7.5** Client understands that ADP's Services are based solely on the information provided by Client and/or otherwise available for ADP in connection with the Services about Client's business established within a particular jurisdiction and other written correspondence that is in reply to ADP's questions regarding the registration process or otherwise provided by Client. Client authorizes ADP to rely upon such in providing the Tax Registration Services. ADP is not responsible for Tax Registration Services provided hereunder based on any inaccurate information supplied by Client or the failure by Client to provide ADP with information relating to the registration process.
- 14.7.6** Client understands that, for reasons beyond ADP's reasonable control, ADP may not be successful in securing an employment tax account number for Client in any particular jurisdiction.
- 14.7.7** ADP is not responsible for any penalties or interest incurred by Client as a result of ADP's failure to timely receive Client's identification numbers.
- 14.8 State Unemployment Insurance (SUI) Management Services.** The following additional terms and conditions apply to the SUI Management Services:
- 14.8.1 Provision and Transfer of Information.** Client will provide ADP with accurate, complete and timely information necessary for ADP to perform the SUI Management Services, including without limitations, the claimants' names, relevant dates, wage and separation information, state-specific required information, and other documentation to support responses to unemployment compensation agencies. Client will transfer this information via (i) on-line connection between ADP and Client's computer system or (ii) inbound data transmissions from Client to ADP, using mutually acceptable communications protocols and delivery methods. Client will promptly notify ADP in writing if Client wishes to modify the communication protocol or delivery method.
- 14.8.2 Definition of Claim; Claim Cap.** For purposes of the SUI Management Services provided under this Agreement and billed to Client, a "claim" shall be defined as a claim notice generated by a state agency as a result of an individual filing for unemployment insurance benefits. In addition, Client acknowledges and agrees that (i) claim notices are typically generated for each state unemployment tax ID number under which an employee had worked and earned wages; (ii) state unemployment agencies generally issue multiple claim notices per individual as identified by a Social Security Number during the benefit eligibility period upon receiving a request for unemployment benefits; and (iii) all such claim notices require review by ADP (e.g., including but not limited to, last employer claims, base period employer claims, periodic qualification claims, additional benefit claims, renewed claims and extended benefit claims). Client further acknowledges and agrees that an applicable claim cap applies to the fees for SUI Management Services and that the claim cap shall be stated on the Sales Order, and will be based on all claim notices processed by ADP as a result of an individual filing for unemployment benefits. The number of claims counted for billing purposes will be reported to Client by ADP as "Claims Processed" via on-line reports.
- 14.9 ADP Wage Garnishment Payment Services.** The following additional terms and conditions apply to the ADP Wage Garnishment Payment Services:
- 14.9.1 Description of Services.** ADP will act solely in the capacity of a third party service provider of payment processing.
- 14.9.2 Client's Use of Services.** Client agrees not to distribute any ADP Checks to Payees in a manner that would allow Payees to access the associated funds before pay date.
- 14.10 Employment Verification Services; Employee Authorized Disclosure.** The following additional terms and conditions apply to the Employment Verification Services and Employee Authorized Disclosure:
- 14.10.1 Employment Verification Services.** Client authorizes Verification Agents to disclose, on Client's behalf, Verification Data to Verifiers, who wish to obtain or verify any of Client's employees' (former employees', and if included in Client's payroll data, independent contractors' and former independent contractors') Verification Data. Verification Data will be disclosed to Verifiers who certify they are entitled to receive such data (as described below) pursuant to FCRA, and, in the case of income information requests, who additionally certify they have a record of the individual's consent to such disclosure or who utilize a salary key ("Employment Verification Services"). In accordance with FCRA, Verification Data may be provided to Verifiers where (i) the individual has applied for a benefit (such as credit, other employment or social services assistance); (ii) the individual has obtained a benefit and the Verifier is seeking to (a) determine whether the individual is qualified to continue to

receive the benefit; and/or (b) collect a debt or enforce other obligations undertaken by the individual in connection with the benefit; or (iii) the Verifier is otherwise entitled under FCRA to obtain the Verification Data. In certifying they have a record of the individual's consent, Verifiers generally rely on the individual's signature on the original application as authorization for the Verifier to access the individual's income data at the time of the application and throughout the life of the obligation. Client understands that Verifiers are charged for commercial verifications processed through ADP or its Verification Agents.

**14.10.1.1 Data Quality.** If requested by ADP, Client agrees to work with ADP during implementation to produce a test file and validate Verification Data using validation reports made available by ADP or its Verification Agents. If Client uses ADP's hosted payroll processing services, ADP will update its system with the applicable Verification Data available in ADP's payroll processing system.

**14.10.1.2 Notice to Furnishers of Information: Obligations of Furnishers of Information** ("Notice to Furnishers"). Client certifies that it has read the Notice to Furnishers provided to Client at the following URL: <https://www.consumerfinance.gov/rules-policy/regulations/1022/m/#ImageM2>. Client understands its obligations as a data furnisher set forth in such notice and under FCRA which include duties regarding data accuracy and investigation of disputes, and certifies it will comply with all such obligations. Client further understands that if it does not comply with such obligations, ADP may correct incorrect Verification Data on behalf of Client or terminate the Employment Verification Services upon 90 days prior written notice to Client.

**14.10.1.3 Archival Copies.** Notwithstanding anything to the contrary in the Global Master Terms and Conditions, Client agrees that, after the termination of the Employment Verification Services, ADP and its Verification Agents may maintain archival copies of the Verification Data as needed to show the discharge and fulfillment of obligations to Client's current and former employees and independent contractors and the provisions of Section 4 will continue to apply during the time that ADP and its Verification Agents maintain any such archival copies.

**14.10.2 Employee Authorized Disclosure.** ADP may disclose or use Personal Data of a Client's current or former employee or independent contractor where such individual requests and consents to such use or disclosure for the individual's personal benefit (e.g., to verify an individual's identity in connection with a bank account application) ("Employee Authorized Disclosure").

**14.10.3 Continuation of Services.** Client understands and agrees that Verification Data and/or Personal Data provided by Client or its vendors in connection with the Services may be used, subject to the terms and conditions of this Section, to provide Employment Verification Services and, at the individual's request, Employee Authorized Disclosures after this Agreement expires or is terminated.

**14.11 Essential ACA Services.** The following terms shall apply to Essential ACA Services.

**14.11.1** Client must use ADP Workforce Now payroll, HR and benefits services in order to purchase and implement Essential ACA. For the avoidance of doubt, all Forms filed by ADP with the IRS on behalf of Client will be filed electronically; any Forms sent to Client for its employees by ADP shall be sent in paper form, and, if Client has ADP's iPay functionality, ADP will also make Forms accessible to Client employees electronically. It will then be Client's responsibility to distribute the Forms directly to its employees.

**14.11.2 Client ACA Liaison.** Client shall designate in writing to ADP the name of one person who shall serve as the Client ACA Liaison for Essential ACA ), and such Client ACA Liaison shall have the authority to (i) provide information, instructions and direction on behalf of Client, and (ii) grant or provide approvals (other than Amendments) required or permitted under the Agreement in connection with Essential ACA. Client shall designate an alternate Client ACA Liaison in the event the principal Client ACA Liaison is not available.

**14.11.3 Disclaimer.** NOTWITHSTANDING ANYTHING TO THE CONTRARY CONTAINED HEREIN OR IN THE SCOPE OF SERVICES, CLIENT EXPRESSLY ACKNOWLEDGES THAT ADP IS NOT THE "ADMINISTRATOR" OR "PLAN ADMINISTRATOR" AS DEFINED IN SECTION 3(16)(A) OF ERISA AND SECTION 414(g) OF THE CODE, RESPECTIVELY, NOR IS ADP A "FIDUCIARY" WITHIN THE MEANING OF ERISA SECTION 3(21). ADP SHALL NOT EXERCISE ANY DISCRETIONARY AUTHORITY OR DISCRETIONARY CONTROL RESPECTING MANAGEMENT OF ANY BENEFIT PLANS SPONSORED OR OFFERED BY CLIENT. ADP HAS NO DISCRETIONARY AUTHORITY OR DISCRETIONARY RESPONSIBILITY IN THE ADMINISTRATION OF THE CLIENT'S BENEFIT PLAN(S). ADP EXPRESSLY DISCLAIMS ANY WARRANTY, EITHER EXPRESS OR IMPLIED, INCLUDING ANY IMPLIED WARRANTIES OF MERCHANTABILITY OR FITNESS FOR A PARTICULAR PURPOSE, NON-INFRINGEMENT, NON-INTERRUPTION OF USE, AND FREEDOM FROM PROGRAM ERRORS WITH RESPECT TO ESSENTIAL ACA, THE ADP APPLICATION PROGRAMS OR ANY THIRD-PARTY SOFTWARE DELIVERED BY ADP.

**14.11.4 Important Tax Information (IRS Disclosure):** Notwithstanding Client's engagement of ADP to provide Essential ACA, please be aware that Client remains responsible for the timely filing of all required reports and filings, and the timely payment of Client penalty obligations. The Internal Revenue Service recommends that employers enroll in the U.S. Treasury Department's Electronic Federal Tax Payment System (EFTPS) to monitor their accounts and ensure that timely tax payments are being made for them, and that online enrollment in EFTPS is available at [www.eftps.gov](http://www.eftps.gov); an enrollment form may also be obtained by calling (800) 555-4477.

**14.11.5 Additional Requirements.** Client further understands that Essential ACA may be modified as ADP may deem appropriate to assist ADP in complying with its obligations.

**14.12 ADP Marketplace and Use of ADP APIs.**

- 14.12.1 Disclaimer.** ADP may provide Client with access to the ADP Marketplace. Client acknowledges that any third party application or service purchased by Client through the ADP Marketplace is provided by a third party and not ADP and ADP makes no endorsements, representations or warranties (including any representations or warranties regarding compliance with laws) regarding such application or service. Client will enter into a relationship directly with the third party provider of such application or service. Any application or service purchased through the ADP Marketplace will be governed exclusively by the terms and conditions agreed to by Client and the third party provider and not by this Agreement. ADP will not provide any advice, service or support with respect to any third party application or service purchased on the ADP Marketplace.
- 14.12.2 Transmitting Information to Third Parties.** In the event that Client elects to use an API to provide any Client Content or employee or plan participant information to any third party, Client represents that it has acquired any consents or provided any notices required to transfer such content or information and that such transfer does not violate any applicable international, federal, state, or local laws and/or regulations. ADP shall not be responsible for any services or data provided by any such third party.
- 14.12.3 Use of the ADP APIs.** Client will use the ADP APIs to access Client's information only. Client may not use any robot, spider, or other automated process to scrape, crawl, or index the ADP Marketplace and will integrate Client's application with the ADP Marketplace only through documented APIs expressly made available by ADP. Client also agrees that Client will not (a) use the ADP Marketplace or any ADP API to transmit spam or other unsolicited email; (b) take any action that may impose an unreasonable or disproportionately large load on the ADP infrastructure, as determined by ADP; or (c) use the ADP APIs or the ADP Marketplace in any way that threatens the integrity, performance or reliability of the ADP Marketplace, Services or ADP infrastructure. ADP may limit the number of requests that Client can make to the ADP API gateway to protect ADP's system or to enforce reasonable limits on Client's use of the ADP APIs. Specific throttling limits may be imposed and modified from time to time by ADP.

**14.13 ESS & MSS Technology.** The following additional terms and conditions apply to the ESS & MSS Technology.

- 14.13.1** Client acknowledges that Client's employees or participants may input information into the self-service portions of the ADP Application Programs. ADP shall have no responsibility to verify, nor does ADP review the accuracy or completeness of the information provided by Client's employees or participants to ADP using any self-service features. ADP shall be entitled to rely upon such information in the performance of the Services under this Agreement as if such information was provided to ADP by Client directly.

**14.14 ADP Connect Services.** The following additional terms and conditions apply to ADP Connect Services:

- 14.14.1 Additional Third-Party Terms.** During the Term of this Agreement, Client's use and access to ADP Connect may be subject to additional terms of services which will be included within ADP Connect. Prior to enabling ADP Connect or certain functionality therein, Client shall ensure that its Users of ADP Connect click through and accept such additional terms of service.

**14.15 History Conversion Services.** The following additional terms and conditions apply to the History Conversion Services:

- 14.15.1 Client Obligations.** As a prerequisite to receiving the History Conversion Services (the "**Project**"), Client shall (i) allocate sufficient resources to the Project; (ii) provide ADP with a single point of contact and access in order to perform an extraction of historical payroll documents from a single vendor database of reports or registers (if multiple points of contact are required which necessitates additional data extraction work efforts and/or separate security access rights, additional fees may apply); and (iii) perform an inventory of converted historical data and review results in accordance with the timeline set forth below. In addition, if necessary, Client shall complete and validate any data mapping and be responsible for final review of data during the mapping process. If errors in the data mapping are discovered following Client's final validation, corrections to the historical data may be required. Any required data mapping must be completed within sixty (60) days of the date that Client is first able to commence the data mapping processing (the "**Data Mapping Completion Date**"). If Client fails to complete the data mapping by the Data Mapping Completion Date, then additional monthly storage charges shall apply.
- 14.15.2 Client Consent.** Client consents to the direct import of historical payroll documents and historical data into ADP Workforce Now.
- 14.15.3 Completion of History Conversion Services.** Upon completion of the History Conversion Services, Client shall immediately notify ADP if the History Conversion Services and deliverables outlined in the Sales Order have not been satisfactorily delivered. The History Conversion Services will be deemed accepted by Client if no response has been received within five (5) days of the date of completion of such Services.

## 15 Miscellaneous

- 15.1 Amendment.** This Agreement may not be modified, supplemented or amended, except by a writing signed by the authorized representatives of ADP and Client.
- 15.2 Assignment.** Neither this Agreement, nor any of the rights or obligations under this Agreement, may be assigned by any party without the prior written consent of the other party, such consent not to be unreasonably withheld. However, Client may assign any or all of its rights and obligations to any other Client Group member and ADP may assign any or all of its rights and obligations to any Affiliate of ADP, provided that any such assignment shall not release the assigning party from its obligations under this Agreement. This Agreement is binding upon and inures to the benefit of the parties hereto and their respective successors and permitted assigns.
- 15.3 Subcontracting.** Notwithstanding Section 15.2, ADP reserves the right to subcontract any or all of the Services, provided that ADP remains fully responsible under this Agreement for the performance of any such subcontractor. For the avoidance of doubt, third parties

used by ADP to provide delivery or courier services, including the postal service in any country or any third party courier service, and banking institutions, are not considered subcontractors of ADP.

- 15.4 Entire Agreement.** This Agreement constitutes the entire agreement and understanding between ADP and Client with respect to its subject matter and merges and supersedes all prior discussions, agreements and understandings of every kind and nature between the parties. No party will be bound by any representation, warranty, covenant, term or condition other than as expressly stated in this Agreement. Except where the parties expressly state otherwise in a relevant exhibit, annex, appendix or schedule, in case of conflict or inconsistency between these Global Master Terms and Conditions and any such exhibit, annex, appendix or schedule, the Global Master Terms and Conditions will prevail and control. Purchase orders or statements of work submitted to ADP by Client will be for Client's internal administrative purposes only and the terms and conditions contained in any purchase order or statements of work will have no force and effect and will not amend or modify this Agreement.
- 15.5 No Third Party Beneficiaries.** Except as expressly provided herein or in an applicable exhibit, annex, appendix or schedule, nothing in this Agreement creates, or will be deemed to create, third party beneficiaries of or under this Agreement. Client agrees that ADP's obligations in this Agreement are to Client only, and ADP has no obligation to any third party (including, without limitation, Client's personnel, directors, officers, employees, Users and any administrative authorities).
- 15.6 Force Majeure.** Any party to this Agreement will be excused from performance of its obligations under this Agreement, except for Client's obligation to pay the fees to ADP pursuant to Section 11, for any period of time that the party is prevented from performing its obligations under this Agreement due to an act of God, war, earthquake, civil disobedience, court order, labor disputes or disturbances, governmental regulations, communication or utility failures or other cause beyond the party's reasonable control. Such non-performance will not constitute grounds for breach.
- 15.7 Waiver.** The failure by any party to this Agreement to insist upon strict performance of any provision of this Agreement will not constitute a waiver of that provision. The waiver of any provision of this Agreement shall only be effective if made in writing signed by the authorized representatives of ADP and Client and shall not operate or be construed to waive any future omission or breach of, or compliance with, any other provision of this Agreement.
- 15.8 Headings.** The headings used in this Agreement are for reference only and do not define, limit, or otherwise affect the meaning of any provisions hereof.
- 15.9 Severability.** If any provision of this Agreement is finally determined to be invalid, illegal or unenforceable by a court of competent jurisdiction, the validity, legality or enforceability of the remainder of this Agreement will not in any way be affected or impaired and such court shall have the authority to modify such invalid, illegal or unenforceable provision to the extent necessary to render such provision valid, legal or enforceable, preserving the intent of the parties to the furthest extent permissible.
- 15.10 Relationship of the Parties.** The performance by ADP of its duties and obligations under this Agreement will be that of an independent contractor and nothing contained in this Agreement will create, construe or imply an agency, joint venture, partnership or fiduciary relationship of any kind between ADP and Client. None of ADP's employees, agents or subcontractors will be considered employees, agents or subcontractors of Client. Unless expressly stated in this Agreement, none of ADP, its employees, agents or its subcontractors may enter into contracts on behalf of, bind, or otherwise obligate Client in any manner whatsoever.
- 15.11 Governing Law.** This Agreement is governed by the laws of the State of New York without giving effect to its conflict of law provisions.
- 15.12 Communications to U.S. Based Employees.** Client agrees that ADP may use Client's U.S.-based employee and/or participant name, email and mailing address to provide information about products and/or services offered by ADP directly such employees and/or participants. Client may elect for ADP to cease such communications upon 30 days' prior written notice. In addition, each communication sent by ADP will comply with applicable laws and will enable the recipient to opt-out of receiving additional similar communications from ADP.
- 15.13 Jurisdiction.** Any disputes that may arise between ADP and Client regarding the performance or interpretation of this Agreement shall be subject to the exclusive jurisdiction of the state and federal courts of the nonmoving party. The parties hereby irrevocably consent to the exclusive jurisdiction of the state and federal courts of the nonmoving party and waive any claim that any proceedings brought in such courts have been brought in an inconvenient forum. **THE PARTIES HEREBY IRREVOCABLY WAIVE THEIR RIGHT TO TRIAL BY JURY.**
- 15.14 Counterparts.** This Agreement may be signed in two or more counterparts by original, .pdf (or similar format for scanned copies of documents) or facsimile signature, each of which shall be deemed an original, but all of which together shall constitute one and the same instrument.
- 15.15 Notices.** All notices required to be sent or given under this Agreement will be sent in writing and will be deemed duly given and effective (i) immediately if delivered in person, or (ii) upon confirmation of signature recording delivery, if sent via an internationally recognized overnight courier service with signature notification requested to Client at the address indicated on the signature page hereof or to ADP at 99 Jefferson Road, Parsippany, New Jersey 07054, Attention: Legal Department or to any other address a party may identify in writing from time to time. A copy (which shall not constitute notice) of all such notices shall be sent to ADP at One ADP Boulevard, MS 425, Roseland, New Jersey 07068, Attention: General Counsel and to Client at the address indicated on the signature page hereof.
- 15.16 Survival.** Those provisions which by their content are intended to, or by their nature would, survive the performance, termination, or expiration of this Agreement, shall survive termination or expiration of this Agreement.

## Appendix – Data Validation and Dual Maintenance

The data validation and dual maintenance Services (“DV/DM Services”) are in addition to the other Services provided to Client. The DV/DM Services are provided virtually only. Consultants are typically scheduled in advance. Consultant will communicate with the ADP project team during the project, and Client hereby authorizes consultant to do so. ADP will provide 60 hours of DV/DM Services to Client during the ADP Workforce Now implementation. If Client does not utilize the DV/DM Services in a reasonable time from the agreed upon start date for these Services or does not continue to engage with consultant thereafter, consultant may be reassigned to another project.

**Master File Data Validation Services** This is the process of comparing the data loaded into Client’s ADP Workforce Now (WFN) against Client’s legacy vendor system data, to confirm all data has been migrated accurately to ADP Workforce Now.

Consultant Responsibilities:

- Provide payroll and ADP Workforce Now expertise in support of data validation phase during implementation of Services
- Audit all master file data, aligning with implementation project timeline
  - *Clients with more than 800 employees may be validated using a sample group of employees across departments, positions, pay groups, FLSA status, etc. (to be determined by Client)*
- Identify missing/incorrect data from audit findings and communicate these to Client and ADP
- Assist Client in minor data corrections up to 5% of audit findings
  - *Additional data correction Services may require additional consultant hours. The rate will be based on volume of changes and may require further scoping to determine fees.*
- Deliver project updates and audit results to Client, including status, variances and recommendations. Frequency of updates and format of deliverable will be determined with Client upon launch of project.

Client Responsibilities:

- Provide consultant with timely access to ADP Workforce Now to assist in minor data corrections
- Validate all entries made by consultant for accuracy
- Provide master file data source reports/data in Excel format for validation (email changes are not acceptable)

Service Delineations of Master File Data Validation Services:

- The master file data migration to Client’s ADP Workforce Now is a prerequisite to the master file data validation Service and is not part of this Service
- Validation of master file data only, including current active and terminated employees
- Historical data validation is not included
- Client or ADP will provide data mapping detail to facilitate data comparisons
- Client or ADP will provide timeline expectations for Services at least 14 days prior to start date
- These Services are based on one validation of master file load to Client’s ADP Workforce Now
- ADP LaunchPad to be utilized for data exchange with Client.

**Dual Maintenance Services** These Services consist of maintaining Client's ADP Workforce Now in sync with Client’s legacy vendor system from the initial master file data load on ADP Workforce Now until Client’s first payroll processing with ADP.

Consultant Responsibilities:

- Coordinate with Client personnel to define data flow, cycle deadlines and communication requirements. Master file update volume of changes not to exceed 50% of Client’s employee headcount
  - *Ex: 250 active employees, changes can include multiple updates for up to 125 of those employees*
- Provide data entry support on ADP Workforce Now to keep legacy and WFN systems in sync until Client’s first payroll processing with ADP.
- Perform clarity check on data submitted by Client, communicate with Client and ADP regarding missing or illegible data input

Client Responsibility:

- Validate all entries made by consultant for accuracy
- Provide the Client data required for updating Client’s ADP Workforce Now
- Provide data input in PDF or Excel (email changes are not acceptable)
- Data input to be provided bi-weekly, in a timely, consistent manner (Client’s deadlines to provide data will be agreed upon)

Service Delineations of Dual Maintenance Services:

- The master file data migration to Client’s ADP Workforce Now is a prerequisite to the dual maintenance Services and is not part of these Services

- Test scenario data (fictional) is not included in scope of Services
- ADP Workforce Now updates are included, but other systems are excluded from scope
- Weekly data entry by consultant to be completed Wednesdays through Fridays if reasonably possible
- ADP Launchpad to be utilized for data exchange with Client
- Pricing for a project duration of up to 90-days
  - *Timeline extensions may require an additional sales order*

**Client Obligations Include:**

- Not significantly alter the scope of work beyond that which is included in the Sales Order.
- Have sufficient employee resources for the project.
- Provide consultant with ADP login credentials, administrative security access privileges and proper access to ADP Workforce Now. If required system access is not available, the project start may be delayed and the assigned consultant may not be available.
- Sign off on weekly status reports, including hours worked by consultant, provided that if Client signoff is not received within five (5) business days of consultant's request for signoff, the report will be deemed accepted by Client.
- Approve all validations completed by consultant as well as Client-assisted testing results, provided that if Client approval is not received within five (5) business days of consultant's request for approval, the validation or testing result will be deemed approved by Client.
- Immediately notify ADP if the DV/DM Services have not been satisfactorily delivered. These Services will be deemed accepted by Client if ADP has not been notified otherwise within five (5) Business Days of the Services delivery date.

**Termination:** Either party can terminate the DV/DM Services at any time for any reason by providing at least ten (10) Business Days' advance written notice to the other party. Upon such termination, all fees and expenses for such Services that are incurred by Client prior to the termination date will be immediately due and payable by Client.

**No Show and Cancellation Policy**

Please be aware of the following policy for no shows/late cancellations for scheduled calls. If you cannot make a scheduled call, please alert the consultant as soon as possible. The consultant will wait for up to 15 minutes for attendees to join the call after which the call will be considered a no show. A late cancellation is any cancellation with less than 24 hours' notice. In the case of a no show or late cancellation, the following applies:

- First occurrence: recorded instance, no charge in time.
- Second occurrence: recorded instance, 30 minutes of time will be deducted from the engagement.
- Additional occurrences: the length of the scheduled session will be deducted from the engagement.



**Teresa Melvin**  
**Primary**  
 Tazewell County  
 11 S 4th St  
 Pekin, IL 61554-4253  
 United States

## Sales Order

March 17 2026 | Quote #02-2026-108079

### Recurring Fees and Considerations

Number of Employees: 450 on Tazewell County

Per Processing	Count	Min	Base	Rate	Bi-Weekly	Annual
Workforce Now Payroll Solutions	450		\$67.50	\$1.82	\$886.50	\$23,049.00
• Essential Plus Payroll						Included
Delivery Fee (if applicable)	1			\$20.00	\$20.00	\$520.00
Employment and Income Verification	450				\$0.00	\$0.00

Monthly Processing	Count	Min	Base	Rate	Monthly	Annual
Workforce Now HCM Solutions	450			\$7.70	\$3,465.00	\$41,580.00
• Enhanced HR						Included
• HCM Analytics						Included
• Benefits Administration						Included
Application Programming Interface Central (API)	450			\$1.68	\$756.00	\$9,072.00
Workforce Now Time and Attendance	350	\$265.00		\$3.85	\$1,347.50	\$16,170.00
• Essential Time						Included
• Time Analytics						Included
Client/Industry Specific Functionality w/ Workforce Now Modules	350			\$0.85	\$297.50	\$3,570.00
Professional Services: Company and Payroll Historical Documents + Employee Data History	1				\$0.00	\$0.00
Additional Jurisdiction (if applicable)	2+				\$11.00/month	
International Employees Rate (if applicable)					\$3.10/month	

Annual Processing	Count	Min	Base	Rate	Annual
Year End Forms, W2s or 1099s	450			\$6.95	\$3,127.50

### Total Annual Investment

**\$97,088.50**

### Other Considerations

Hardware and Other Fees	Count	Rate	Total
• Professional Services: Company and Payroll Historical Documents + Employee Data History	1	\$0.00	\$0.00
• Affordable Care Act (ACA) Data History	1	\$1,800.00	\$1,800.00

Implementation	Total
• Implementation for Workforce Now Payroll Solutions	\$1,727.00
• Implementation for Workforce Now HCM Solutions	\$3,626.70
• Implementation for Workforce Now Time and Attendance	\$1,347.06
• Implementation for Client/Industry Specific Functionality w/ Workforce Now Modules	\$2,500.00



<b>\$ Total Setup</b>	<b>\$23,700.00</b>
<b>Discount Value</b>	<b>(\$12,699.24)</b>
<b>Total Net Setup</b>	<b>\$11,000.76</b>

Please note: The Total Setup fees listed above does not include any fees for ADP Professional Services as these amounts will vary based on the scope and complexity of the project.

## Important Project and Billing Information

Billing for Payroll Processing Services, HCM and any module bundled into the single per employee per processing fee for payroll, is billed immediately following the client's first payroll processing. The billing count is based on the number of pays submitted during each processing period, therefore total billing may fluctuate.

Billing for Application Programming Interface Central (API) will begin on the date it is available for use by the CLIENT in a production environment. The billing count is based on all unique lives in the database paid in the previous calendar month. Clients may purchase consulting services from ADP to assist with API development efforts at a rate of \$250/hour. ADP will only perform consulting work when agreed to by both parties in writing in advance.

Billing for all modules bundled under HCM Solutions will begin on the date the ADP Product or Service is available for use by the CLIENT in a production environment. The billing count is based on all unique lives in the database paid in the previous calendar month. Any non-terminated employees based outside the United States will be billed separately as International Employees.

Billing for Essential Time will begin on the date Essential Time is available for use by the CLIENT in a production environment. The billing count is based on all non-terminated employees in the Time Module. This count includes practitioners and supervisors.

Unemployment Claims in excess of the 10% claims cap will be billed at \$36.00 per claim. The fee for optional hearing representation is \$155.00 per appearance. Attorney representation required in certain states and is subject to change (currently: AZ, DE, KY, MO, NC, SC, SD, and WV). Representation fee not to exceed actual attorney fees. Optional service available through non-ADP affiliated attorneys. Attorneys will be retained on behalf of client for limited purpose of representing Client at the hearing. No referral fee applies. No attorney-client relationship exists or will be formed between ADP and Client.

### Other

ADP's Fees for Service will be debited directly out of client's bank account of their choosing seven (7) days from invoice date. ADP will send all invoices to [tmelvin@tazewell-il.gov](mailto:tmelvin@tazewell-il.gov)

Expiration Date: 3/26/2026

## Important Professional Services Information

Data Validation and Dual Maintenance: ADP will provide, and Client will receive, up to a maximum of 60 hours of data validation and dual maintenance Services ("DV/DM Services") at no cost to Client. In the event Client (x) terminates the DV/DM Services or (y) fails to go live with the Services (as defined in the Agreement), Client shall reimburse ADP for all costs associated with the DV/DM Services provided as of either (xx) the termination date or (yy) Client's failing to go live with the Services as reasonably determined by ADP, in each case at the rate of \$170 per hour.

### APPLICATION PROGRAMMING INTERFACE CENTRAL (API)

Project Description: Provide secure access to subset of client's ADP Workforce Now data via the ADP API offering.

Project Prerequisites: 1) Client is using the current version of ADP Workforce Now. 2) Client has Developer resources who are familiar with HTTP, REST, JSON and OAuth who can utilize the APIs once they are made available to them.

ADP Responsibilities: 1) Provide client access to ADP API Documentation. 2) Issue SSL certificate and credentials to ADP API user(s). 3) ADP is unable to provide development support but is available to answer general API support questions as needed.

Client Responsibilities: 1) Create middleware utilizing ADP APIs to achieve business objectives 2) Engage development resources as needed to analyze and document all the field mappings from the desired system of record into or out of ADP Workforce Now.

Consulting: Expert resources are available to guide you through your development efforts. Consulting includes selecting appropriate APIs for your projects, guidance on interacting with the applications you're integrating with, and development best practices to drive a project to completion quickly.



In the event that the Client terminates this Sales Order and work hereunder has already commenced, Client agrees that it is responsible for all costs and fees incurred by ADP prior to the effective date of such termination and such amounts shall be due and payable by Client to ADP according to the Client's previously-established payment terms with ADP.

History conversion: History Conversion Services include up to seven years of historical data from a single database source. Additional fees may apply for (i) conversion of historical data from more than one database or (ii) more than seven years of historical data.

**Summary**

Estimated Annual Net Investment: \$97,088.50 Total Net Implementation: \$11,000.76

Please note: The Estimated Annual Net Investment and Total Net Implementation fees listed above does not include any fees for ADP Professional Services as these amounts will vary based on the scope and complexity of the project.

The ADP Services Listed on this Sales Order are provided at the prices set forth herein and in accordance with the ADP Master Services Agreement (or other similar agreement governing ADP's services), which shall include any appendix, exhibit, addendum, schedule or other similar document attached thereto or accompanying this Sales Order. By signing below you are acknowledging and agreeing to such terms and conditions and to the listed prices.

ADP, Inc.

Client: Tazewell County

Signature: \_\_\_\_\_

Signature: [Handwritten Signature]

Name: \_\_\_\_\_

Name: Brett Grimm

Title: \_\_\_\_\_

Title: County Board Chairman

Date: \_\_\_\_\_

Date: 3-25-2026

**ADDENDUM**  
to  
**GLOBAL MASTER SERVICES AGREEMENT**  
between  
**ADP, INC.**  
and  
**Tazewell County**

This addendum ("**Addendum**"), made and effective as of the date of the last signature hereto between ADP, Inc. ("**ADP**") and Tazewell County ("**Client**"), contains changes, modifications, revisions and additions to the ADP Global Master Services Agreement dated of even date herewith between ADP and Client (as amended herein, the "**Agreement**").

In consideration of the mutual covenants contained in the Agreement and in this Addendum, and for other good and valuable consideration, notwithstanding anything to the contrary in the Agreement, ADP and Client agree as follows:

1. The first page/signature page of the Agreement is hereby amended by revising the first sentence to read the following: "ADP and Client agree that ADP shall provide Client with the following services in accordance with the terms set forth in this Global Master Services Agreement (including the applicable Sales Order (as defined herein)) and in accordance with ADP's cooperative purchasing agreement with OMNIA Partners, Contract No. R250901, which resulted from a competitive selection process by which OMNIA Partners selected ADP as a qualified vendor of managed business/outsourced services."

All other terms and conditions of the Agreement remain in full force and effect. In the event of any conflict between the terms and conditions of this Addendum and the terms and conditions of the Agreement, this Addendum shall prevail. The terms defined in the Agreement and used in this Addendum shall have the same respective meanings as set forth in the Agreement, unless clearly otherwise defined in this Addendum. This Addendum may be executed in multiple original copies, identically worded, and each such executed copy constitutes an original. Electronic signatures in connection with the electronic signature delivery system utilized by ADP and signatures transferred in .pdf or a similar format for scanned copies of documents are original signatures for all purposes of this Addendum and the Agreement.

IN WITNESS WHEREOF, this Addendum to the Agreement is hereby executed by an authorized representative of each party hereto as of the last date below.

**ADP, Inc.**

**Tazewell County**

\_\_\_\_\_  
[ADP Signature]

\_\_\_\_\_  
[Client Signature]

\_\_\_\_\_  
[ADP Name]

*Brett Grimm*  
\_\_\_\_\_  
[Client Name]

\_\_\_\_\_  
[ADP Title]

*County Board Chairman*  
\_\_\_\_\_  
[Client Title]

\_\_\_\_\_  
[ADP Date]

*3-25-2026*  
\_\_\_\_\_  
[Client Date]

# IMPLEMENTATION CONSULTING: **ADP** **ADVANTAGE**



## ROBUST DATA

- Pay rate
- Check history
- Salary history
- ACA history
- Position history



## SYSTEM CUSTOMIZATION

- Portal content (includes DataCloud Analytics)
- Policies and profiles
- Self-service tools
- Custom activities (new hire, termination and onboarding)



## TRAINING

- Tailored to your users
- On-site practitioner
- Virtual Employee Self-Service Training
- Virtual Manager Self-Service Training



## WORLD-CLASS SUPPORT

- Account Manager
- Utilization Scorecard

# Implementation Support



## Offering Details

- **60 hours** for 2 key focus areas - Masterfile Data Validation and Dual Maintenance
- Sales can request Golden Ticket Approval for
  - Clients in competitive situations &
  - Clients that don't have capacity to manage these tasks
- Fees are covered by ADP
- Supported by Professional Services Certified Partners only; Sales can select partner in ESO

## Masterfile Data Validation

- Aid client in auditing all **Masterfile data**
- Clients with >800 ee's may be validated using a sample group of employees
- Identify missing/incorrect data from audit finding
  - Communicate findings to ADP/client for resolution
- Assist with **minor data corrections** (up to 5%); client responsible for remainder of updates
  - Additional data corrections would require a separate SOW
- Historical Data Validation is excluded

## Dual Maintenance

- **Data Entry support** on WFN to keep legacy system and WFN in sync
  - Includes **updates to WFN only**; updates to legacy system are out of scope
    - Changes up to 50% of client's employee headcount
      - i.e. if 250 active ee's, changes can include multiple updates for up to 125 ee's
- Timeframe – Initial Masterfile load until client's first ADP processing

# Client-Side Implementation Support

60 Hours of free client-side implementation support representing a \$9,000 value.

This dedicated individual will provide the following services of 2 Key focus areas (Data Validation and Dual Maintenance) as an extension of your team supporting the team during the implementation process.

## Data Validation Services

### Services:

- Consultant/ADP Resource to provide payroll and system expertise in support of data validation phase of implementation prior to go live
- Aid Client in auditing all master file data, aligning with implementation project timeline
  - Clients with >800 employees may be validated using a sample group of employees across departments, positions, pay groups, FLSA status, etc. (to be determined by Client)
- Identify missing/incorrect data from audit findings, communicating to Client and ADP for resolution
- Assist in minor data corrections (up to 5% of audit findings),
  - Additional data corrections may require additional hours – rate based on volume of changes, may require further scoping to determine fees.
- Client to provide WorkforceNow System access to consultant/ADP Resource in a timely manner to assist in minor data corrections
- Client responsible to validate all entries made by consultant/ADP Resource for accuracy

### Service Delineations:

- Validation of master file data only, including current active/terminated employees
- Historical data validation is excluded from scope
- Client will provide master file data source reports/data in Excel format for validation
- Client or ADP will provide data mapping details to facilitate proper comparisons
- Client or ADP will provide timeline expectations for services 14 days prior to start date needed
- Pricing is based on one validation of master file load to Client's WorkforceNow System

### Deliverables:

- Project Updates and results of audit will be delivered to Client, including status, variances and recommendations. Frequency of updates and format of deliverable will be determined with Client upon launch of project.

## Dual Maintenance

### Services:

- Coordinate with Client personnel to define data flow, cycle deadlines and communication requirements
- Consultant/ADP Resource to provide data entry support on WorkforceNow, to keep legacy/WorkforceNow systems in sync during parallel(s)
- Perform reasonability check on data submitted, communicate with Client and ADP regarding missing or illegible input
- Client responsible to validate all entries made by consultant/ADP Resource for accuracy

### Service Delineations:

- Test scenario data (fictional) is not included in scope of services
- Client to provide consultant/ADP Resource with WorkforceNow system access in a timely manner
- Format of data input to be provided in PDF or Excel, emailed changes excluded from scope
- Data input to be provided bi-weekly, in a timely, consistent manner by Client (deadlines agreed upon start)
- WorkforceNow updates included, other systems excluded from scope
- Client or ADP will provide defined scope of data fields included
- Data entry to be completed Wednesdays-Friday if possible
- SharePoint site to be utilized for data exchange with Client
- Master file update volume of changes not to exceed 50% of headcount
  - Ex: 250 active employees, changes can include multiple updates for up to 125 of those employees
- Pricing for a project duration of up to 90-days
  - Timeline extensions may require a new SOW

1384

# MEET THE TEAM

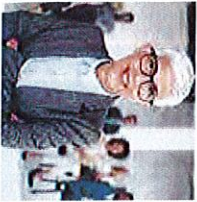

## IMPLEMENTATION SUPPORT

### Project Manager

- Dedicated associate focused on Payroll and Time & Attendance
- Human Capital Management Consultant to focus on modules like HR, Benefits, and Talent Suite.
- Weekly touchpoints on progress of each stage of your ADP Implementation.
- Project plan tailored to you desired go live date with ADP



## ONGOING SUPPORT

### Dedicated Account Manager

- Team of client service professionals for your on-going service needs
- Takes questions through scheduled appointments or phone
- Proactive communication to help you stay ahead of the curve in terms of compliance & industry changes
- Specialized Teams to provide additional expertise on the HCM spectrum: HR, Benefits, & Workforce Management



## SALES SUPPORT

### Your District Manager

- Monitors progress of Implementation
- Facilitates collection of necessary documentation and transfer of critical business information gathered during Sales Process
- Responsible for introduction and transition to Implementation Team.

*"I'm very happy with the service that we receive. We have a dedicated service representative that we can call. They know me, they know our product, and they know what our needs are, so it we need help they're able to either help us immediately or at least find that help very quickly. I've not seen this kind of personal service with other providers."*

**Chuck Fimble**  
Chief Talent Officer  
KIPP Houston Public Schools

# IMPLEMENTATION OVERVIEW

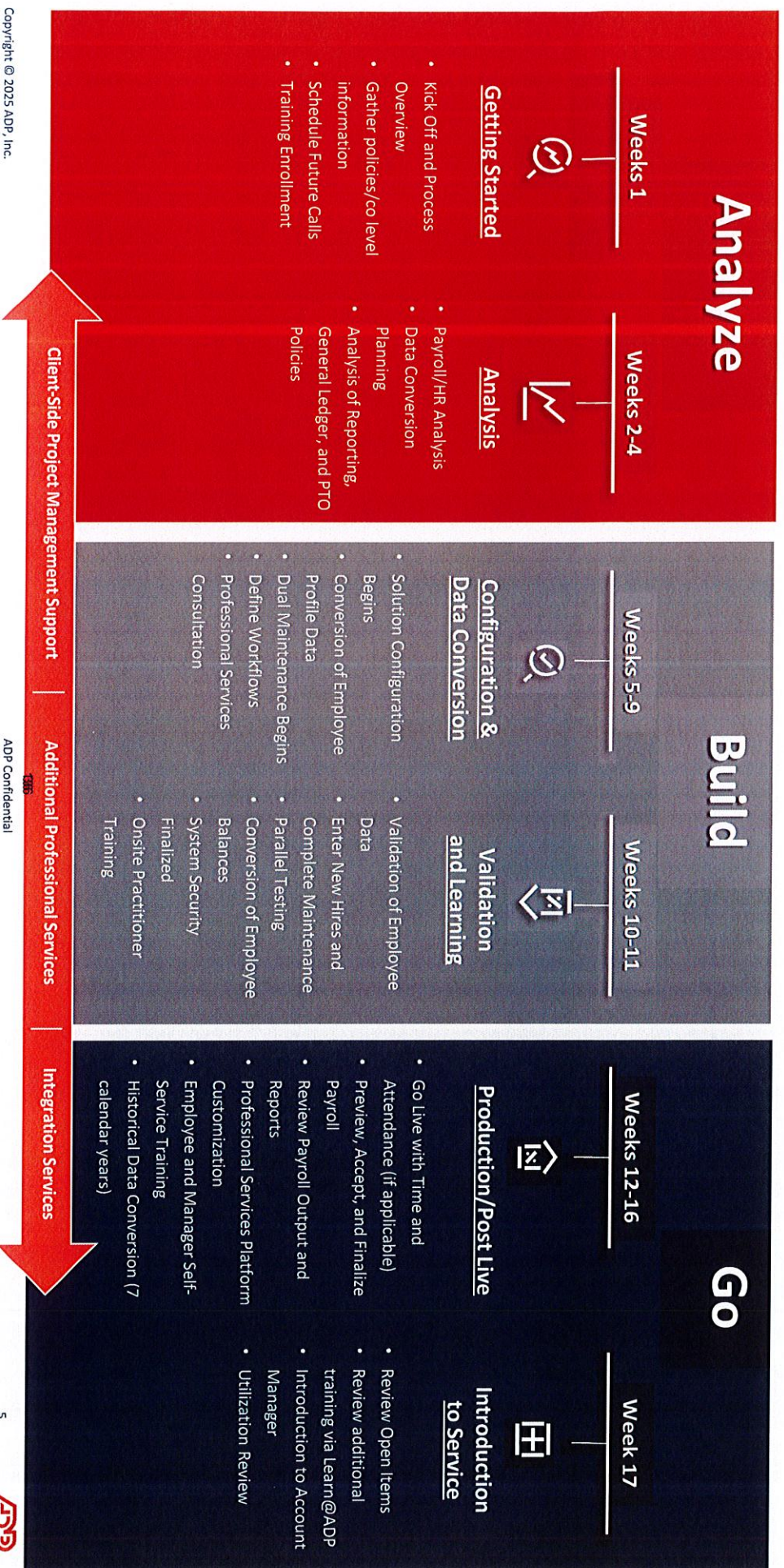

**COMMITTEE REPORT**

RM-26-02

Mr. Chairman and Members of the Tazewell County Board:

Your Risk Management Committee has considered the following RESOLUTION and recommends that it be adopted by the Board:

-----  
**RESOLUTION**

WHEREAS, the County's Risk Management Committee recommends to the County Board to approve the disposal of a damaged Sheriff's Office squad car as well as the associated interfund and budget transfers; and

WHEREAS, the vehicle was involved in an automobile accident on January 5, 2026 resulting in an estimated cost to repair of \$15,359.57 which is below the County's automobile insurance deductible of \$25,000.00; and

WHEREAS, the vehicle (2020 Dodge Durango) was scheduled for trade in by the Sheriff's Office in FY26; and

WHEREAS, the Sheriff's Office is recommending the vehicle not be repaired due to the cost and remaining life of the vehicle but instead sold for parts as-is to Auto Link by the Risk Management Fund; and

WHEREAS, the Risk Management Fund will transfer \$12,000.00 to the General Fund – Sheriff's Department to be applied toward the purchase of a squad car later in FY26 as a replacement for the approximated lost trade-in value of the damaged vehicle; and

WHEREAS, this transfer represents a lower cost to the Risk Management Fund than repairing the vehicle. This is in addition to the revenue to be received by the Risk Management Fund from selling the damaged vehicle to Auto Link which results in an even lower net cost to the Fund; and

WHEREAS, a General Fund budget transfer is needed to allow for the expenditure of the funds received from the Risk Management Fund as follows:

Increase 100-200-4920 Transfer from Risk Mgmt Fund	\$12,000.00
Increase 100-200-5571 Squad Cars	\$12,000.00; and

WHEREAS, a Risk Management Fund budget transfer is needed to allow for the transfer of funds from the Risk Management Fund as follows:

Increase 252-610-5700 Transfer to General Fund	\$12,000.00
Decrease 252-610-5224 Physical Loss/Damage Replacement	\$12,000.00; and

WHEREAS, both transfers represent a \$0 net increase to the Funds' budgets.

THEREFORE BE IT RESOLVED that the County Board approve the recommendation and authorize the Treasurer to transfer \$12,000.00 from the Risk Management Fund (252-610-5700) to the General Fund – Sheriff's Department (100-200-4920).

BE IT FURTHER RESOLVED that the County Clerk notifies the County Board Office, the Sheriff, Finance Director, Treasurer, and Auditor of this action.

PASSED THIS 25<sup>th</sup> DAY OF MARCH, 2026.

ATTEST:

  
\_\_\_\_\_  
Tazewell County Clerk

  
\_\_\_\_\_  
Tazewell County Board Chairman



## E3 Collision

E3 Collision  
215 N 3RD ST, Pekin, IL. 61554, PEKIN, IL 61554  
Phone: (309) 347-1242

Workfile ID: 28c3680d  
Federal ID: 93-4628813  
License Number: UDL8668

### Preliminary Estimate

**Customer: Tazewell County Sheriff**

**Job Number:**

Written By: Crystal Harms

Insured: Tazewell County Sheriff	Policy #:	Claim #:
Type of Loss:	Date of Loss:	Days to Repair: 0
Point of Impact:		

<b>Owner:</b> Tazewell County Sheriff	<b>Inspection Location:</b> E3 Collision 215 N 3RD ST Pekin, IL. 61554 PEKIN, IL 61554 Repair Facility (309) 347-1242 Business	<b>Insurance Company:</b>
--	--	---------------------------

### VEHICLE

2020 DODG Durango Pursuit AWD (Fleet) 4D UTV 6-3.6L Gasoline Sequential MPI

VIN: 1C4RDJFG9LC205714	Interior Color:	Mileage In:	Vehicle Out:
License:	Exterior Color:	Mileage Out:	
State:	Production Date:	Condition:	Job #:

#### TRANSMISSION

Automatic Transmission  
4 Wheel Drive

#### POWER

Power Steering  
Power Brakes  
Power Windows  
Power Locks  
Power Mirrors  
Heated Mirrors  
Power Driver Seat

#### DECOR

Dual Mirrors  
Privacy Glass  
Console/Storage  
Overhead Console

#### CONVENIENCE

Air Conditioning  
Intermittent Wipers  
Tilt Wheel  
Cruise Control  
Rear Defogger  
Keyless Entry  
Message Center  
Steering Wheel Touch Controls  
Rear Window Wiper  
Telescopic Wheel  
Climate Control  
Dual Air Condition  
Backup Camera  
Parking Sensors

#### RADIO

AM Radio  
FM Radio  
Stereo  
Search/Seek  
Auxiliary Audio Connection

#### SAFETY

Drivers Side Air Bag  
Passenger Air Bag  
Anti-Lock Brakes (4)  
4 Wheel Disc Brakes  
Traction Control  
Stability Control  
Front Side Impact Air Bags  
Head/Curtain Air Bags  
Communications System  
Hands Free Device

#### SEATS

Cloth Seats  
Bucket Seats  
Reclining/Lounge Seats

#### WHEELS

Aluminum/Alloy Wheels

#### PAINT

Clear Coat Paint

#### OTHER

Fog Lamps  
Rear Spoiler

#### TRUCK

Rear Step Bumper

**Preliminary Estimate**

**Customer: Tazewell County Sheriff**

**Job Number:**

2020 DODG Durango Pursuit AWD (Fleet) 4D UTV 6-3.6L Gasoline Sequential MPI

Line	Oper	Description	Part Number	Qty	Extended Price \$	Labor	Paint
1	#	PDR Hood		1	275.00		
2	<b>FRONT BUMPER</b>						
3	Repl	RT Trim bezel	5113678AC	1	40.90	0.1	
4	Repl	Wire harness	68311370AB	1	168.00		
5	#	RT Fog Light Assembly		1	189.00	0.5	
6	Repl	RT Bumper cover upper bracket	68227824AA	1	74.90	Incl.	
7	Repl	RT Bumper cover side bracket	68411418AE	1	11.15	Incl.	
8		O/H front bumper				2.7	
9	<>	Repl Bumper cover w/o ft prk aid	6RP39TZAA	1	734.00	Incl.	3.0
10		Add for Clear Coat					1.2
11		Add for fog lamps				0.4	
12	Repl	Energy absorber	68381725AA	1	87.25	Incl.	
13	Repl	RT Bumper cover retainer	68227824AA	1	74.90	0.1	
14	Repl	License bracket	5113718AC	1	40.90	0.2	
15	R&I	Impact bar w/o adaptive cruise				0.3	
16	R&I	Impact bar w/o adaptive cruise				0.3	
17	Repl	Applique w/frt park aid	68377772AA	1	172.00	Incl.	
18	<b>GRILLE</b>						
19	Repl	Grille	68307807AA	1	76.60	0.5	
20	Repl	Nameplate "DODGE"	68325386AB	1	145.00	Incl.	
21	Repl	Sight shield	5113714AC	1	119.00	0.2	
22	<b>FRONT LAMPS</b>						
23	Repl	RT Fog lamp assy	68275510AC	1	468.00	Incl.	
24		Aim fog lamps				0.4	
25	Repl	RT Headlamp assy Halogen, w/o LED daytime light chrome bezel	68299136AF	1	675.00	Incl.	
26		Aim headlamps				0.5	
27	<b>RADIATOR SUPPORT</b>						
28	Repl	Upper tie bar	5156109AB	1	418.00	Incl.	0.9
29	Repl	RT Support brace	68223547AB	1	438.00	Incl.	0.4
30		Add for Clear Coat					0.1
31	Repl	LT Support brace	5156117AB	1	488.00	Incl.	0.4
32		Add for Clear Coat					0.1
33	Repl	LT Support bracket	68227827AA	1	155.00	Incl.	
34	Repl	RT Support bracket	68227826AA	1	151.00	Incl.	
35	Repl	Upper tie bar brace	5156112AA	1	93.00	0.2	0.3
36		Add for Clear Coat					0.1
37	Repl	Underbody shield 5.7 liter	68308842AE	1	349.00	0.3	
38	Repl	Lower support	5156113AA	1	615.00	12.5	1.4
39		Overlap Minor Panel					-0.2
40	<b>COOLING</b>						
41	Repl	Trans cooler	68596421AA	1	442.00 m	0.4	
42	Repl	Radiator w/HD cooling w/R134A	68273308AA	1	819.00 m	Incl.	

**Preliminary Estimate**

**Customer: Tazewell County Sheriff**

**Job Number:**

2020 DODG Durango Pursuit AWD (Fleet) 4D UTV 6-3.6L Gasoline Sequential MPI

43	Repl	Recovery tank	68244088AA	1	194.00		0.3	
44	Repl	Fan assy w/HD cooling	52014787AC	1	869.00	m	Incl.	
45	Repl	RT Side shield w/R134A	68235734AA	1	22.80		Incl.	
46	<b>AIR CONDITIONER &amp; HEATER</b>							
47	Repl	Condenser w/trans cooler	55038003AG	1	629.00	m	Incl.	
48		AC Service evacuate & recharge R134a				m	1.4	
49		AC Service evacuate & recharge R1234yf				m	1.7	
50		AC Service refrigerant recovery				m	0.4	
51	<b>HOOD</b>							
52	Repl	Latch w/o remote start	4589701AB	1	135.00		Incl.	
53	<b>FENDER</b>							
54	Repl	RT Fender	55369734AD	1	437.00		2.0	2.0
55		Overlap Major Non-Adj. Panel						-0.2
56		Add for Clear Coat						0.4
57		Add for Edging						0.5
58		Add for Clear Coat						0.1
59	*	Rpr RT Upper rail (HSS)				s	<u>1.0</u>	<u>0.5</u>
60		Overlap Major Non-Adj. Panel						-0.2
61	Repl	RT Wheel flare w/o body color	57010620AF	1	265.00		0.3	
62	#	Transmission Fluid		2	14.00			
63	Repl	RT Filler panel	68258780AA	1	32.65		0.2	
64	Repl	RT Fender liner	68309298AE	1	122.00		Incl.	
65	R&I	LT Wheel flare w/o body color					0.3	
66	<b>ELECTRICAL</b>							
67	Repl	High note horn	68386896AA	1	124.00	m	Incl.	
68	Repl	Low note horn	68386895AA	1	48.45	m	Incl.	
69	#	Antifreeze		3	75.00			
70	*	Repl <u>Wiring harness 3.6 liter</u>	68399843AB	1	1,985.00		<u>1.0</u>	
71	#	Plug Repalcements Sublet Charge		1	400.00			
72	<b>FRONT DOOR</b>							
73	**	Repl Opt OEM RT Door shell	55369462AO	1	1,062.57		5.6	3.4
74		Overlap Major Adj. Panel						-0.4
75		Add for Clear Coat						0.6
76	#	Antifreeze		2	50.00			
77	Repl	RT Applique	57010262AI	1	167.00		Incl.	
78	#	Clips/Rivets/Retainers		1	200.00			
<b>SUBTOTALS</b>					<b>14,152.07</b>		<b>33.8</b>	<b>14.4</b>

**Preliminary Estimate**

**Customer: Tazewell County Sheriff**

**Job Number:**

2020 DODG Durango Pursuit AWD (Fleet) 4D UTV 6-3.6L Gasoline Sequential MPI

**ESTIMATE TOTALS**

<b>Category</b>	<b>Basis</b>	<b>Rate</b>	<b>Cost \$</b>
Parts			14,152.07
Parts Discount	\$ 11,886.50	-20.0 %	-2,377.30
Body Labor	33.8 hrs @	\$ 64.00 /hr	2,163.20
Paint Labor	14.4 hrs @	\$ 64.00 /hr	921.60
Paint Supplies			500.00
Subtotal			15,359.57
<b>Grand Total</b>			<b>15,359.57</b>

ANY AND ALL RUST REPAIRS ARE NOT GUARANTEED! WE ARE NOT RESPONSIBLE FOR PARTS DELAYS AS WE DO NOT HOLD PARTS IN SHOP.

ILLINOIS LAW REQUIRES THAT VEHICLE REPAIRERS MUST BE LICENSED IN ACCORDANCE WITH SECTION 5-301 OF THE ILLINOIS VEHICLE CODE.

Estimate calculated using a preset user threshold amount for the paint and material cost.

## Preliminary Estimate

**Customer: Tazewell County Sheriff**

**Job Number:**

2020 DODG Durango Pursuit AWD (Fleet) 4D UTV 6-3.6L Gasoline Sequential MPI

Estimate based on MOTOR CRASH ESTIMATING GUIDE and potentially other third party sources of data. Unless otherwise noted, (a) all items are derived from the Guide DR3TG11, CCC Data Date 02/16/2026, and potentially other third party sources of data; and (b) the parts presented are OEM-parts. OEM parts are manufactured by or for the vehicle's Original Equipment Manufacturer (OEM) according to OEM's specifications for U.S. distribution. OEM parts are available at OE/Vehicle dealerships or the specified supplier. OPT OEM (Optional OEM) or ALT OEM (Alternative OEM) parts are OEM parts that may be provided by or through alternate sources other than the OEM vehicle dealerships with discounted pricing. Asterisk (\*) or Double Asterisk (\*\*) indicates that the parts and/or labor data provided by third party sources of data may have been modified or may have come from an alternate data source. Tilde sign (~) items indicate MOTOR Not-Included Labor operations. The symbol (<>) indicates the refinish operation WILL NOT be performed as a separate procedure from the other panels in the estimate. Non-Original Equipment Manufacturer aftermarket parts are described as Non OEM, A/M or NAGS. Used parts are described as LKQ, RCY, or USED. Reconditioned parts are described as Recond. Recored parts are described as Recore. NAGS Part Numbers and Benchmark Prices are provided by National Auto Glass Specifications. Labor operation times listed on the line with the NAGS information are MOTOR suggested labor operation times. NAGS labor operation times are not included. Pound sign (#) items indicate manual entries.

Some 2024 vehicles contain minor changes from the previous year. For those vehicles, prior to receiving updated data from the vehicle manufacturer, labor and parts data from the previous year may be used. The CCC ONE estimator has a list of applicable vehicles. Parts numbers and prices should be confirmed with the local dealership.

The following is a list of additional abbreviations or symbols that may be used to describe work to be done or parts to be repaired or replaced:

### SYMBOLS FOLLOWING PART PRICE:

m=MOTOR Mechanical component. s=MOTOR Structural component. T=Miscellaneous Taxed charge category. X=Miscellaneous Non-Taxed charge category.

### SYMBOLS FOLLOWING LABOR:

D=Diagnostic labor category. E=Electrical labor category. F=Frame labor category. G=Glass labor category. M=Mechanical labor category. S=Structural labor category. (numbers) 1 through 4=User Defined Labor Categories.

### OTHER SYMBOLS AND ABBREVIATIONS:

Adj.=Adjacent. Algn.=Align. ALU=Aluminum. A/M=Aftermarket part. Blnd=Blend. BOR=Boron steel. CAPA=Certified Automotive Parts Association. CFC=Carbon Fiber. D&R=Disconnect and Reconnect. HSS=High Strength Steel. HYD=Hydroformed Steel. Incl.=Included. LKQ=Like Kind and Quality. LT=Left. MAG=Magnesium. Non-Adj.=Non Adjacent. NSF=NSF International Certified Part. O/H=Overhaul. Qty=Quantity. Refn=Refinish. Repl=Replace. R&I=Remove and Install. R&R=Remove and Replace. Rpr=Repair. RT=Right. SAS=Sandwiched Steel. Sect=Section. STS=Stainless Steel. Subl=Sublet. UHS=Ultra High Strength Steel. N=Note(s) associated with the estimate line.

CCC ONE Estimating - A product of CCC Intelligent Solutions Inc.

The following is a list of abbreviations that may be used in CCC ONE Estimating that are not part of the MOTOR CRASH ESTIMATING GUIDE:

BAR=Bureau of Automotive Repair. EPA=Environmental Protection Agency. NHTSA= National Highway Transportation and Safety Administration. PDR=Paintless Dent Repair. VIN=Vehicle Identification Number.

**Preliminary Estimate**

**Customer: Tazewell County Sheriff**

**Job Number:**

2020 DODG Durango Pursuit AWD (Fleet) 4D UTV 6-3.6L Gasoline Sequential MPI

**PARTS SUPPLIER LIST**

<b>Line</b>	<b>Supplier</b>	<b>Description</b>	<b>Price</b>
73	Hawk Auto 7911 W. Roosevelt Road Forest Park IL 60130	#55369462AO Opt OEM RT Door shell Quote: 21808453214 Expires: 03/20/26	\$ 1,062.57

**COMMITTEE REPORT**

Mr. Chairman and Members of the Tazewell County Board:

Your Executive Committees have considered the following RESOLUTION and recommends that it be adopted by the Board:

-----  
**RESOLUTION**

WHEREAS, the County's Executive Committee recommends to the County Board to approve the quote from Abel Monument Company for the Medal of Honor Monument; and

WHEREAS, this item was voted on and approved by the Tazewell County voters in 2024; and

WHEREAS, the monument will be placed on the Courthouse grounds and will be dedicated to three Medal of Honor recipients; and

WHEREAS, the total project cost is quoted at \$16,300.00; and

WHEREAS, this is accounted for in the FY26 Capital Improvement Plan Fund budget.

THEREFORE BE IT RESOLVED that the County Board approve the recommendation.

BE IT FURTHER RESOLVED that the County Clerk notifies the County Board Office, County Clerk, Facilities Director, the Auditor, and Finance Office of this action.

PASSED THIS 25<sup>th</sup> DAY OF MARCH, 2026.

ATTEST:

  
\_\_\_\_\_  
Tazewell County Clerk

  
\_\_\_\_\_  
Tazewell County Board Chairman

**From:** [Sandy Gullette](mailto:Sandy.Gullette)  
**To:** [Sandy Gullette](mailto:Sandy.Gullette)  
**Subject:** FW: [EXTERNAL] Medal of Honor Quote  
**Date:** Monday, December 1, 2025 1:51:49 PM

---

**From:** Jackie Matheney <[jackie@abelmonument.com](mailto:jackie@abelmonument.com)>  
**Sent:** Monday, December 1, 2025 1:44 PM  
**To:** John C. Ackerman <[JCAckerman@tazewell-il.gov](mailto:JCAckerman@tazewell-il.gov)>  
**Cc:** Steve Matheney <[steve@abelmonument.com](mailto:steve@abelmonument.com)>  
**Subject:** [EXTERNAL] Medal of Honor Quote

**CAUTION:** This email originated from outside of the organization. Do not click links or open attachments unless you recognize the sender and know the content is safe.

Hello...

Below is the quote for the Medal of Honor memorial.

\$13,600.00 Jet Black Granite 4-0 x 0-8 x 6-0  
\$ 700.00 Installation  
\$ 2,000.00 Etchings (3 photo and 1 logo - colored)  
\$ 16,300.00 TOTAL

I have also included Steve in this email. You may reach out to him, should you have any questions.

Thank you.  
Jackie

## Jackie Matheney

Accounts Receivable

### Abel Monument Co.

1917 N. 8<sup>th</sup> Street, PO Box 757  
Pekin IL 61554  
P: 309.346.4186 \* F: 309.346.2672  
[jackie@abelmonument.com](mailto:jackie@abelmonument.com) \* [www.abelmonument.com](http://www.abelmonument.com)

My Office Hours:

Monday, Thursday, Friday 8:00 am – 4:30 pm

Saturday 9:00 am – 12:00 noon

Picture size 20 x 10"



THE MEDAL OF HONOR IS PRESENTED BY  
THE PRESIDENT OF THE UNITED STATES IN  
THE NAME OF THE UNITED STATES CONGRESS  
TO MEMBERS OF THE MILITARY THAT HAVE  
DISTINGUISHED THEMSELVES THROUGH ACTS OF  
CONSPICUOUS GALLANTRY AND INTREPIDITY AT RISK  
OF LIFE ABOVE AND BEYOND THE CALL OF DUTY

**TAZEWELL COUNTY RECIPIENTS**

<b>WILLIAM REED</b> 1839 - 1918	<b>DR. THOMAS L. MURPHY</b> 1844 - 1920	<b>JOHN AYERS</b> 1837 - 1913
--	--	--------------------------------------



Picture size 13 x 19"

Picture size 13 x 19"

Picture size 11 x 19"

ORDER NO:	COLOR: JET BLACK	UPPER COLOR:	ADDITIONAL INFO:
PO BOX WEIGHT:	4-O & 8-O & D-O PS FLAT TOP	<input type="checkbox"/> BRASS <input type="checkbox"/> COPPER <input type="checkbox"/> SILVER <input type="checkbox"/> BRONZE	<input type="checkbox"/> ENAMEL ON BACK <input type="checkbox"/> ENAMEL ON REEF W/ K <input type="checkbox"/> ENAMEL ON REEF W/ C <input type="checkbox"/> LASER ETCHING FRONT <input type="checkbox"/> LASER ETCHING BACK <input type="checkbox"/> LASER LETTERING F/ & <input type="checkbox"/> BRASS HOLES
COMPANY NAME: ASBL MON		<input type="checkbox"/> SHIP KEY <input type="checkbox"/> SHIP WHEEL <input type="checkbox"/> SHIP <input type="checkbox"/> SHIP BURN <input type="checkbox"/> SHIP BURN <input type="checkbox"/> SHIP BURN	
TICKET NO: 27024/27048		<input type="checkbox"/> SHIP <input type="checkbox"/> SHIP <input type="checkbox"/> SHIP	
COORDINATOR NO:	CARPING SHAPE CARVE: <input type="checkbox"/> YES <input checked="" type="checkbox"/> NO		
DATE: 02/25/15	<input type="checkbox"/> SHIP BURN <input checked="" type="checkbox"/> SHIP BURN <input type="checkbox"/> SHIP BURN		
NUMBER OF LETTERS OVER 100: 213		SPECIAL LETTERING #:	
CAMEO INFO: <input type="checkbox"/> NECKER <input type="checkbox"/> NECKER WITH R <input type="checkbox"/> MACE ONLY		CUSTOMER SUPPLIED CAMEO: <input type="checkbox"/> YES <input checked="" type="checkbox"/> NO	
BRONZE INFO: <input type="checkbox"/> BRONZE ONLY <input type="checkbox"/> BRONZE WITH R <input type="checkbox"/> BRONZE ONLY		CUSTOMER SUPPLIED BRONZE: <input type="checkbox"/> YES <input checked="" type="checkbox"/> NO	
NOTES: COLOR LASER ETCHINGS MAY DIFFER IN APPEARANCE AND ARE NOT GUARANTEED. THE RIBBON AT THE TOP IS COLOR LASER ETCHED. THE PORTRAITS ON THE BOTTOM ARE BLACK AND WHITE.			
PLEASE CHECK SP/ING/ DATE & DESIGN IF APPROVED PLEASE SIGN BY ENOUGH TIME APPROVAL WILL BE MADE THAT ALL INFORMATION IS CORRECT AND THE ADDITIONAL CHANGES WILL BE MADE THE CHANGES SHOWN & COMPLETE DELIVERED WILL NOT BE ACCEPTED UNLESS THE OTHER APPROVALS FOR THE CHANGES ARE IN HAND BY THE TIME PROVIDED FOLLOWING & BE APPROVED BY THE TIME OF THE DELIVERY DATE OR FIRST			

**COMMITTEE REPORT**

Mr. Chairman and Members of the Tazewell County Board:

Your Executive Committee has considered the following RESOLUTION and recommends that it be adopted by the Board:

-----  
**RESOLUTION**

WHEREAS, the County's Executive Committee recommends to the County Board to authorize the addition of a Roth option to the Nationwide 457(B) Deferred Compensation Plan; and

WHEREAS, this action is required under the SECURE Act 2.0 to comply with IRS rules; and



WHEREAS, this change will be effective on February 11, 2026; and

THEREFORE BE IT RESOLVED that the County Board approve this recommendation and authorization.

BE IT FURTHER RESOLVED that the County Clerk notifies the County Board Office, Payroll, and Human Resources of this action.

PASSED THIS 25<sup>th</sup> DAY OF MARCH 2026

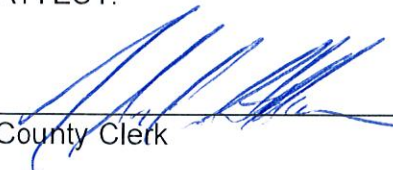
ATTEST:

 _____ County Clerk	 _____ County Board Chairman
--	--

**GOVERNMENTAL 457(b) PLAN  
ADOPTION AGREEMENT**

By executing this Governmental 457(b) Plan Adoption Agreement (the "Agreement"), the undersigned Employer agrees to establish or continue a 457(b) Plan for its Employees. The Plan adopted by the Employer consists of the Governmental 457(b) Basic Plan Document (the "BPD") and the elections made under this Agreement (collectively referred to as the "Plan"). An Employer may jointly co-sponsor the Plan by signing a Participating Employer Adoption Page, which is attached to this Agreement. **This Plan is effective as of the Effective Date identified on the Signature Page of this Agreement.**

In completing the provisions of this Adoption Agreement, unless designated otherwise, selections under the Deferral column apply to all Salary Deferrals (including Roth Deferrals and Catch-Up Contributions).

*[Note: Certain vendor agreements associated with the Plan may restrict the application of certain Plan provisions. Additionally, some State and local laws may restrict the election of certain provisions under the Plan. Please consult with legal counsel to assess the impact of State laws, local laws and/or applicable vendor agreements on the Plan.]*

**SECTION 1  
EMPLOYER INFORMATION**

**1-1 EMPLOYER INFORMATION.**

Name: County of Tazewell, IL

Address: 11 S 4Th St Ste 114

City, State, Zip Code: Pekin, Illinois 61554-4281

Telephone: (309) 477-2269

**1-2 EMPLOYER IDENTIFICATION NUMBER (EIN).** 37-6002170

**1-3 TYPE OF EMPLOYER.** (Optional)

*[Note: To adopt this Plan, the Employer must be a State, political subdivision of a State, or any agency or instrumentality of a State or political subdivision of a State, as provided under Code §457(e)(1)(A). A non-governmental tax-exempt organization, as described under Code §457(e)(1)(B), may not adopt this Plan.]*

(a) State

(b) Political Subdivision of a State

(c) Agency or Instrumentality of a State

(d) Other governmental entity: (Describe) \_\_\_\_\_

**1-4 EMPLOYER'S TAX YEAR END.** (Optional) The Employer's tax year ends November 30

**1-5 RELATED EMPLOYERS.** (Optional) List any Related Employers. A Related Employer must execute a Participating Employer Adoption Page for Employees of that Related Employer to participate in this Plan.

**SECTION 2  
PLAN INFORMATION**

**2-1 PLAN NAME.** County of Tazewell 457(b) Deferred Compensation Plan

Original Effective Date: June 8, 1993

Restatement Effective Date: February 11, 2026

Plan identifier (optional): \_\_\_\_\_

**2-2 TYPE OF PLAN.** This Plan is a Governmental 457(b) Plan.

The Plan is intended to be a FICA Replacement Plan (as defined under Section 3.08 of the BPD).

2-3 **TYPE OF CONTRIBUTIONS. (Check all that apply.)**

- (a) Salary Deferral Contributions
- (b) Employer Matching Contributions
- (c) Employer Contributions
- (d) Rollover Contributions

2-4 **PLAN YEAR.**

- (a) Calendar year.
- (b) The 12-consecutive month period ending on \_\_\_\_\_ each year.
- (c) Other: \_\_\_\_\_

2-5 **PLAN ADMINISTRATOR.**

- (a) The Employer identified in AA §1-1.
- (b) Name: \_\_\_\_\_  
Address: \_\_\_\_\_  
Telephone: \_\_\_\_\_

2-6 **FROZEN PLAN.** Check this AA §2-6 if the Plan is a frozen Plan to which no contributions will be made. (See Section 3.01(c) of the BPD).

- This Plan is a frozen Plan effective \_\_\_\_\_

*[Note: As a frozen Plan, the Employer will not make any contributions with respect to Plan Compensation earned after such date and no Participant will be permitted to make any contributions to the Plan after such date. In addition, no Employee will become a Participant after the date the Plan is frozen.]*

2-7 **DEFINITION OF DISABLED.** An individual is considered Disabled for purposes of applying the provisions of this Plan if:

- (a) The individual is covered by the Employer's disability insurance plan and is determined to be disabled under such plan.
- (b) The individual is determined to be disabled by the Social Security Administration under Section 223(d) of the Social Security Act for purposes of determining eligibility for Social Security benefits.
- (c) The Plan Administrator determines an individual is unable to engage in any substantial gainful activity by reason of a medically determinable physical or mental impairment that can be expected to result in death or which has lasted or can be expected to last for a continuous period of not less than 12 months. The permanence and degree of such impairment shall be supported by medical evidence. The Plan Administrator may establish reasonable procedures for determining whether a Participant is Disabled.

*[Note: An Employer may elect any or all of the elections above. If more than one is selected, the hierarchy for determining whether an individual is considered Disabled is in the order listed above, unless described otherwise under separate administrative procedures or as described below.]*

- (d) Alternative definition of Disabled: \_\_\_\_\_

*[Note: Any alternative definition described in this subsection (d) will apply uniformly to all Participants under the Plan. The Employer may describe different definitions of Disabled for different purposes under the plan.]*

<b>SECTION 3 ELIGIBLE EMPLOYEES</b>
---

3-1 **ELIGIBLE EMPLOYEES.** In addition to the Employees identified in Section 2.02 of the BPD, the following Employees are excluded from participation under the Plan with respect to the contribution source(s) identified in this AA §3-1. (See Sections 2.02(d) and (c) of the BPD for rules regarding the effect on Plan participation if an Employee changes between an eligible and ineligible class of employment.)

- | Deferral                 | Match                    | ER                       |  |
|--------------------------|--------------------------|--------------------------|--|
| <input type="checkbox"/> | <input type="checkbox"/> | <input type="checkbox"/> | (a) No exclusions.   |
| <input type="checkbox"/> | <input type="checkbox"/> | <input type="checkbox"/> | (b) Collectively Bargained Employees (as defined in Section 1.11 of the BPD), unless the Collective Bargaining Agreement provides otherwise. |

Deferral	Match	ER	
<input type="checkbox"/>	<input type="checkbox"/>	<input type="checkbox"/>	(c) Non-resident aliens who receive no compensation from the Employer which constitutes U.S. source income.
<input type="checkbox"/>	<input type="checkbox"/>	<input type="checkbox"/>	(d) Employees who normally work less than ____ hours a week.
<input type="checkbox"/>	<input type="checkbox"/>	<input type="checkbox"/>	(e) Employees eligible for a 401(k), a 403(b) plan or another 457(b) plan sponsored by the Employer.
<input type="checkbox"/>	<input type="checkbox"/>	<input type="checkbox"/>	(f) Part-Time Employees (as defined in Section 1.39 of the BPD).
<input type="checkbox"/>	<input type="checkbox"/>	<input type="checkbox"/>	(g) Seasonal Employees (as defined in Section 1.57 of the BPD).
<input type="checkbox"/>	<input type="checkbox"/>	<input type="checkbox"/>	(h) Temporary Employees (as defined in Section 1.60 of the BPD).
<input type="checkbox"/>	<input type="checkbox"/>	<input type="checkbox"/>	(i) Employees in an appointed or elected position.
<input type="checkbox"/>	<input type="checkbox"/>	<input type="checkbox"/>	(j) Employees paid on an hourly basis.
<input type="checkbox"/>	<input type="checkbox"/>	<input type="checkbox"/>	(k) Employees paid on a salaried basis.
<input type="checkbox"/>	<input type="checkbox"/>	<input type="checkbox"/>	(l) All other Employees except Part-Time, Temporary and Seasonal Employees.
<input checked="" type="checkbox"/>	<input type="checkbox"/>	<input type="checkbox"/>	(m) Other: <u>Part-time Employees who normally work less than 37.5 hours per week</u>

3-2 **INDEPENDENT CONTRACTORS.** Unless elected otherwise under subsection (a) below, Independent Contractors (as defined in Section 1.35 of the BPD) of the Employer are excluded from participation in the Plan.

Deferral	Match	ER	
<input type="checkbox"/>	<input type="checkbox"/>	<input type="checkbox"/>	(a) Independent Contractors may participate in the Plan.
<input type="checkbox"/>	<input type="checkbox"/>	<input type="checkbox"/>	(b) Describe any special rules applicable to Independent Contractors: _____

*[Note: Select under subsection (a) the types of contributions for which Independent Contractors are eligible. If the Employer elects to allow Independent Contractors to participate in the Plan, the term Employee as used in the Plan shall include the eligible Independent Contractors, as appropriate.]*

<b>SECTION 4</b> <b>MINIMUM AGE AND SERVICE REQUIREMENTS</b>
---

4-1 **ELIGIBILITY REQUIREMENTS – MINIMUM AGE AND SERVICE.** An Eligible Employee (as defined in AA §3-1) who satisfies the minimum age and service conditions under this AA §4-1 will be eligible to participate under the Plan as of such Eligible Employee's Entry Date (as defined in AA §4-2 below).

(a) **Service Requirement.** An Eligible Employee must complete the following minimum service requirements to participate in the Plan.

Deferral	Match	ER	
<input checked="" type="checkbox"/>	<input type="checkbox"/>	<input type="checkbox"/>	(1) There is no minimum service requirement for participation in the Plan.
<input type="checkbox"/>	<input type="checkbox"/>	<input type="checkbox"/>	(2) One Year of Service (as defined in Section 2.03(a)(1) of the BPD and AA §4-3).
<input type="checkbox"/>	<input type="checkbox"/>	<input type="checkbox"/>	(3) The completion of at least ____ Hours of Service during the first ____ months of employment (or the first ____ days of employment) or the completion of a Year of Service (as defined in AA §4-3), if earlier. <ul style="list-style-type: none"> <li><input type="checkbox"/> (i) An Employee who completes the required Hours of Service satisfies eligibility at the end of the designated period, regardless if the Employee actually works for the entire period.</li> <li><input type="checkbox"/> (ii) An Employee who completes the required Hours of Service must also be employed continuously during the designated period of employment. (See Section 2.03(a)(1) of the BPD for rules regarding the application of this subsection (ii).)</li> </ul>
<input type="checkbox"/>	<input type="checkbox"/>	<input type="checkbox"/>	(4) The completion of ____ Hours of Service during an Eligibility Computation

**Deferral      Match      ER**

Period. *[Note: If this (4) is chosen, an Employee satisfies the service requirement immediately upon completion of the designated Hours of Service.]*

(5) Full-time Employees are eligible to participate as set forth in subsection (i). Employees who are “part-time” Employees must complete a Year of Service (as defined in AA §4-3). For this purpose, a full-time Employee is any Employee not defined in subsection (ii).

(i) Full-time Employees must complete the following minimum service requirements to participate in the Plan:

(A) There is no minimum service requirement for participation in the Plan.

(B) The completion of at least \_\_\_\_ Hours of Service during the first \_\_\_\_ months of employment or the completion of a Year of Service (as defined in AA §4-3), if earlier.

(C) Under the Elapsed Time method as defined in AA §4-3 below.

(D) Describe: \_\_\_\_\_

(ii) Part-time Employees must complete a Year of Service (as defined in AA §4-3).

(A) For this purpose, a part-time Employee is any Employee whose normal work schedule is less than:

(I) \_\_\_\_ hours per week.

(II) \_\_\_\_ hours per month.

(III) \_\_\_\_ hours per year.

(B) Describe part-time Employees for this purpose: \_\_\_\_\_

*[Note: A part-time employee must be described as an individual who works less than a specified number of hours during a standard work week.]*

(6) Eligibility service will be determined under the Elapsed Time method as described in AA§4-3 below.

(7) Describe eligibility conditions: \_\_\_\_\_

Describe eligibility conditions: \_\_\_\_\_

(b) **Minimum Age Requirement.** An Eligible Employee (as defined in AA §3-1) must have attained the following age with respect to the contribution source(s) identified in this AA §4-1(b).

**Deferral      Match      ER**

(1) There is no minimum age for Plan eligibility.

(2) Age 21.

(3) Age \_\_\_\_.

(c) **Special eligibility rules.** The following special eligibility rules apply with respect to the Plan: \_\_\_\_\_

*[Note: This subsection (c) may be used to apply the eligibility conditions selected under this AA §4-1 separately with respect to different Employee groups or different contribution formulas under the Plan.]*

4-2 **ENTRY DATE.** An Eligible Employee who satisfies the minimum age and service requirements in AA §4-1 shall be eligible to participate in the Plan as of such Eligible Employee’s Entry Date. For this purpose, the Entry Date is the following date with respect to the contribution source(s) identified under this AA §4-2. *[Note: If any of (b) – (g) is completed for a contribution source, also complete one of (h) – (l) for the same contribution source.]*

**Deferral      Match      ER**

(a) **Immediate.** The date the minimum age and service requirements are satisfied.

(b) **Semi-annual.** The first day of the 1st and 7th month of the Plan Year.

(c) **Quarterly.** The first day of the 1st, 4th, 7th and 10th month of the Plan Year.

(d) **Monthly.** The first day of each calendar month.

Deferral	Match	ER	
<input type="checkbox"/>	<input type="checkbox"/>	<input type="checkbox"/>	(c) <b>Payroll period.</b> The first day of the payroll period.
<input type="checkbox"/>	<input type="checkbox"/>	<input type="checkbox"/>	(f) <b>The first day of the Plan Year.</b>
<input type="checkbox"/>	<input type="checkbox"/>	<input type="checkbox"/>	(g) <b>Describe Entry Date:</b> _____

An Eligible Employee's Entry Date (as defined above) is determined based on when the Employee satisfies the minimum age and service requirements in AA §4-1. For this purpose, an Employee's Entry Date is the Entry Date:

Deferral	Match	ER	
<input type="checkbox"/>	<input type="checkbox"/>	<input type="checkbox"/>	(h) <b>next following</b> satisfaction of the minimum age and service requirements.
<input type="checkbox"/>	<input type="checkbox"/>	<input type="checkbox"/>	(i) <b>coinciding with or next following</b> satisfaction of the minimum age and service requirements.
N/A	<input type="checkbox"/>	<input type="checkbox"/>	(j) <b>nearest</b> the satisfaction of the minimum age and service requirements.
N/A	<input type="checkbox"/>	<input type="checkbox"/>	(k) <b>preceding</b> the satisfaction of the minimum age and service requirements.
N/A	<input type="checkbox"/>	<input type="checkbox"/>	(l) <b>coinciding with or preceding</b> the satisfaction of the minimum age and service requirements.

This section may be used to describe any special rules for determining Entry Dates under the Plan. For example, if different Entry Date provisions apply for the same contribution sources with respect to different groups of Employees, such different Entry Date provisions may be described below.

Deferral	Match	ER	
<input type="checkbox"/>	<input type="checkbox"/>	<input type="checkbox"/>	(m) <b>Describe</b> special rules for determining Entry Dates under the Plan: _____

4-3 **DEFAULT ELIGIBILITY RULES.** In applying the minimum age and service requirements under AA §4-1 above, the following default rules apply with respect to all contribution sources under the Plan:

- **Year of Service.** An Employee earns a Year of Service for eligibility purposes upon completing 1,000 Hours of Service during an Eligibility Computation Period. Hours of Service are calculated based on actual hours worked during the Eligibility Computation Period. (See Section 1.33 of the BPD for the definition of Hours of Service.)
- **Eligibility Computation Period.** If one Year of Service is required for eligibility, the Plan will determine subsequent Eligibility Computation Periods on the basis of Plan Years (see Section 2.03(a)(2)(i) of the BPD). If more than one Year of Service is required for eligibility, the Plan will determine subsequent Eligibility Computation Periods on the basis of Anniversary Years (see Section 2.03(a)(2)(ii) of the BPD).

To override the default eligibility rules, complete the applicable sections of this AA §4-3. If this AA §4-3 is not completed for a particular contribution source, the default eligibility rules apply.

Deferral	Match	ER	
<input type="checkbox"/>	<input type="checkbox"/>	<input type="checkbox"/>	(a) <b>Year of Service.</b> Instead of 1,000 Hours of Service, an Employee earns a Year of Service upon the completion of ____ Hours of Service during an Eligibility Computation Period.
<input type="checkbox"/>	<input type="checkbox"/>	<input type="checkbox"/>	(b) <b>Eligibility Computation Period.</b> The Plan will use Anniversary Years for all Eligibility Computation Periods.
<input type="checkbox"/>	<input type="checkbox"/>	<input type="checkbox"/>	(c) <b>Elapsed Time method.</b> [ <i>Note: Check the same contribution source as checked in AA §4-1(a) above.</i> ] Eligibility service will be determined under the Elapsed Time method. An Eligible Employee (as defined in AA §3-1) must complete a period of service, as designated below, to participate in the Plan. (See Section 2.03(a)(5) of the BPD.) <ul style="list-style-type: none"> <li><input type="checkbox"/> (1) For Deferral, must complete a ____ period of service</li> <li><input type="checkbox"/> (2) For Match, must complete a ____ period of service</li> <li><input type="checkbox"/> (3) For ER, must complete a ____ period of service</li> </ul>

- | Deferral                            | Match                    | ER                       |   |
|-------------------------------------|--------------------------|--------------------------|---|
| <input checked="" type="checkbox"/> | <input type="checkbox"/> | <input type="checkbox"/> | <p>(d) <b>Equivalency Method.</b> For purposes of determining an Employee's Hours of Service for eligibility, the Plan will use the Equivalency Method (as defined in Section 2.03(a)(4) of the BPD). The Equivalency Method will apply to:</p> <ul style="list-style-type: none"> <li><input type="checkbox"/> (1) All Employees.</li> <li><input checked="" type="checkbox"/> (2) Employees who are not paid on an hourly basis. For Employees for whom the Employer maintains hourly records, eligibility will be determined based on actual hours worked.</li> </ul> <p>If this (d) is checked, Hours of Service for eligibility will be determined under the following Equivalency Method.</p> <ul style="list-style-type: none"> <li><input checked="" type="checkbox"/> (3) <b>Monthly.</b> 190 Hours of Service for each month worked.</li> <li><input type="checkbox"/> (4) <b>Weekly.</b> 45 Hours of Service for each week worked.</li> <li><input type="checkbox"/> (5) <b>Daily.</b> 10 Hours of Service for each day worked.</li> <li><input type="checkbox"/> (6) <b>Semi-monthly.</b> 95 Hours of Service for each semi-monthly period worked.</li> <li><input type="checkbox"/> (7) <b>Hours worked.</b> 870 hours worked treated as 1,000 Hours of Service and 435 hours worked treated as 500 Hours of Service.</li> <li><input type="checkbox"/> (8) <b>Regular time hours.</b> 750 regular time hours treated as 1,000 Hours of Service and 375 regular time hours treated as 500 Hours of Service.</li> </ul> |
| <input type="checkbox"/>            | <input type="checkbox"/> | <input type="checkbox"/> | <p>(e) <b>Special eligibility provisions.</b> The following special eligibility provisions apply: _____</p>   |

4-4 **EFFECTIVE DATE OF MINIMUM AGE AND SERVICE REQUIREMENTS.** The minimum age and/or service requirements under AA §4-1 apply to all Employees under the Plan. An Employee will participate with respect to all contribution sources under the Plan as of such Employee's Entry Date, taking into account all service with the Employer, including service earned prior to the Effective Date.

To allow Employees employed on a specified date to enter the Plan without regard to the minimum age and/or service conditions, complete this AA §4-4.

- | Deferral                 | Match                    | ER                       |   |
|--------------------------|--------------------------|--------------------------|---|
| <input type="checkbox"/> | <input type="checkbox"/> | <input type="checkbox"/> | <p>(a) <b>Automatic Eligibility.</b> An Eligible Employee who is employed by the Employer on the following designated date will enter the Plan on the designated date without regard to minimum age and/or service conditions:</p> <ul style="list-style-type: none"> <li><input type="checkbox"/> (1) the Effective Date of this Plan (as designated on the Employer Signature Page, as applicable)</li> <li><input type="checkbox"/> (2) the date the Plan is executed by the Employer (as indicated on the Employer Signature Page)</li> <li><input type="checkbox"/> (3) _____ [insert date]</li> </ul> |
| <input type="checkbox"/> | <input type="checkbox"/> | <input type="checkbox"/> | <p>(b) <b>Describe</b> other effective date provisions: _____</p>   |

4-5 **SERVICE WITH PREDECESSOR EMPLOYER.** Service with the following Predecessor Employers will be counted for purposes of determining eligibility, vesting and/or allocation conditions under this Plan.

- (a) Identify Predecessor Employer(s):

The Plan will count service with the following Predecessor Employers:

	Eligibility	Vesting	Allocation Conditions
<input type="checkbox"/> (1) _____	<input type="checkbox"/>	<input type="checkbox"/>	<input type="checkbox"/>

- (b) The following special rules apply with respect to service with a Predecessor Employer: \_\_\_\_\_

**SECTION 5  
COMPENSATION DEFINITIONS**

5-1 **TOTAL COMPENSATION.** Total Compensation is based on the definition set forth under this AA §5-1. See Section 1.61 of the BPD for a specific definition of the various types of Total Compensation.

- (a) W-2 Wages
- (b) Code §415 Compensation
- (c) “Simplified” Code §415 Compensation
- (d) Wages under Code §3401(a)

*[For purposes of determining Total Compensation, each definition includes pre-tax contributions to a Code §125 cafeteria plan, Code §401(k), Code §403(b) or a Code §457 plan, and qualified transportation fringes under Code §132(f)(4).]*

5-2 **POST-SEVERANCE COMPENSATION.**

(a) **Exclusion of post-severance compensation from Total Compensation.** Total Compensation (as defined in Section 1.61 of the BPD) includes post-severance compensation, to the extent provided in Section 1.61(b) of the BPD. For this purpose, severance pay is always excluded from the definition of Plan Compensation. Other post-severance compensation paid within 2½ months after severance from employment with the Employer or the end of the calendar year in which severance occurs is included in Plan Compensation, unless excluded under this subsection (a). See Section 1.61(b) of the BPD.

The following amounts paid after a Participant’s severance from employment are excluded from Plan Compensation.

- (1) **Unused leave payments.** Payment for unused accrued bona fide sick, vacation, or other leave, but only if the Employee would have been able to use the leave if employment had continued.
- (2) **Deferred compensation.** Payments received by an Employee pursuant to a nonqualified unfunded deferred compensation plan, but only if the payment would have been paid to the Employee at the same time if the Employee had continued in employment and only to the extent that the payment is includible in the Employee’s gross income.

(b) **Continuation payments for disabled Participants.** Unless designated otherwise under this subsection (b), Total Compensation does not include continuation payments for disabled Participants. To count Total Compensation paid after Severance from Employment on account of disability (as defined in Code §22(e)(3)), check the box below.

- Payments to disabled Participants.** Total Compensation shall include post-severance compensation paid to a Participant who is permanently and totally disabled, as defined in Code §22(e)(3).

5-3 **PLAN COMPENSATION.** Plan Compensation is **Total Compensation** (as defined in AA §5-1 above) with the following exclusions described below.

Deferral	Match	ER	
<input checked="" type="checkbox"/>	<input type="checkbox"/>	<input type="checkbox"/>	(a) No exclusions.
N/A	<input type="checkbox"/>	<input type="checkbox"/>	(b) Salary Deferrals (as defined in Section 1.55 of the BPD), pre-tax contributions to a cafeteria plan or a Code §457 plan, and qualified transportation fringes under Code §132(f)(4) are excluded.
<input type="checkbox"/>	<input type="checkbox"/>	<input type="checkbox"/>	(c) All fringe benefits (cash and noncash), reimbursements or other expense allowances, moving expenses, deferred compensation, and welfare benefits are excluded.
<input type="checkbox"/>	<input type="checkbox"/>	<input type="checkbox"/>	(d) Compensation above \$___ is excluded.
<input type="checkbox"/>	<input type="checkbox"/>	<input type="checkbox"/>	(e) Amounts received as a bonus are excluded.
<input type="checkbox"/>	<input type="checkbox"/>	<input type="checkbox"/>	(f) Amounts received as commissions are excluded.
<input type="checkbox"/>	<input type="checkbox"/>	<input type="checkbox"/>	(g) Overtime payments are excluded.
<input type="checkbox"/>	<input type="checkbox"/>	<input type="checkbox"/>	(h) Shift differentials are excluded.
<input type="checkbox"/>	<input type="checkbox"/>	<input type="checkbox"/>	(i) Exclusions as described by the applicable Collective Bargaining Agreement.
<input type="checkbox"/>	<input type="checkbox"/>	<input type="checkbox"/>	(j) Amounts received for services performed for a non-signatory Related Employer are excluded.

*[Note: If this subsection is not elected, amounts received for services*

Deferral	Match	ER	
			<i>performed for a non-signatory Related Employer are INCLUDED in Plan Compensation.]</i>
<input type="checkbox"/>	<input type="checkbox"/>	<input type="checkbox"/>	(k) “Deemed §125 compensation” as defined under Total Compensation. (See Section 1.61(d) of the BPD.)
<input type="checkbox"/>	<input type="checkbox"/>	<input type="checkbox"/>	(l) Amounts received after Severance from Employment are excluded.
<input type="checkbox"/>	<input type="checkbox"/>	<input type="checkbox"/>	(m) Differential Pay (as defined in Section 1.61(e) of the BPD) is excluded.
<input type="checkbox"/>	<input type="checkbox"/>	<input type="checkbox"/>	(n) Describe adjustments to Plan Compensation: _____

5-4 PERIOD FOR DETERMINING COMPENSATION.

- (a) **Compensation Period.** Plan Compensation will be determined on the basis of the following period(s) for the contribution sources identified in this AA §5-4. [Note: If a period other than Plan Year applies for any contribution source, any reference to the Plan Year as it refers to Plan Compensation for that contribution source will be deemed to be a reference to the period designated under this AA §5-4.]

Deferral	Match	ER	
<input checked="" type="checkbox"/>	<input type="checkbox"/>	<input type="checkbox"/>	(1) The Plan Year.
<input type="checkbox"/>	<input type="checkbox"/>	<input type="checkbox"/>	(2) The calendar year ending in the Plan Year.
<input type="checkbox"/>	<input type="checkbox"/>	<input type="checkbox"/>	(3) The Employer's fiscal tax year ending in the Plan Year.
<input type="checkbox"/>	<input type="checkbox"/>	<input type="checkbox"/>	(4) The 12-month period ending on ____ which ends during the Plan Year.

- (b) **Compensation while a Participant.** Unless provided otherwise under this subsection (b), in determining Plan Compensation, only compensation paid while an individual is a Participant under the Plan with respect to a particular contribution source will be taken into account.

To count compensation for the entire Plan Year for a particular contribution source, including compensation paid while an individual is not a Participant with respect to such contribution source, check below. (See Section 1.45 of the BPD.)

Deferral	Match	ER	
<input checked="" type="checkbox"/>	<input type="checkbox"/>	<input type="checkbox"/>	All compensation paid during the Plan Year will be taken into account, including compensation earned while an individual is not a Participant.

**SECTION 6  
EMPLOYER CONTRIBUTIONS**

6-1 **EMPLOYER CONTRIBUTIONS.** Is the Employer authorized to make Employer Contributions under the Plan?

- Yes  
 No [If No, skip to Section 6A.]

[Note: Any Employer Contribution made pursuant to this AA §6 will count towards the Code §457(e)(15) Maximum Contribution Limit. See Section 5.01 of the BPD.]

6-2 **EMPLOYER CONTRIBUTION FORMULA.** For the period designated in AA §6-4(a) below, the Employer will make the following Employer Contributions on behalf of Participants who satisfy the allocation conditions designated in AA §6-5 below. Any Employer Contribution authorized under this AA §6-2 will be allocated in accordance with the allocation formula selected under AA §6-3 and AA §6-4, as applicable.

- (a) **Discretionary contribution.** The Employer will determine in its sole discretion how much, if any, it will make as an Employer Contribution.
- (b) **Fixed contribution.**
- (1) \_\_\_\_\_% of each Participant's Plan Compensation.
  - (2) \$ \_\_\_\_\_ for each Participant.
  - (3) The Employer Contribution will be determined in accordance with the personal service contract or employment contract applicable to the Participant.
  - (4) The Employer Contribution will be determined in accordance with any Collective Bargaining Agreement(s) addressing retirement benefits of Collectively Bargained Employees under the Plan.

- (c) **Service-based contribution.** The Employer will make:
- (1) **Discretionary.** A discretionary contribution determined as a uniform percentage of Plan Compensation or a uniform dollar amount for each period of service designated below.
  - (2) **Fixed percentage.** \_\_\_% of Plan Compensation paid for each period of service designated below.
  - (3) **Fixed dollar.** \$\_\_\_ for each period of service designated below.
- The service-based contribution selected under this (c) will be based on the following periods of service:
- (4) Each Hour of Service
  - (5) Each week of employment
  - (6) Describe period: \_\_\_\_\_
- The service-based contribution is subject to the following rules:
- (7) Describe any special provisions that apply to service-based contribution: \_\_\_\_\_
- (d) **FICA Replacement Contribution.** (See Section 3.08 of the BPD).
- (1) The Employee will make the 7.5% of Plan Compensation mandatory contribution.
  - (2) The Employer will make the 7.5% of Plan Compensation mandatory contribution.
  - (3) The Employee will make a mandatory contribution equal to \_\_\_% of Plan Compensation and the Employer will make a mandatory contribution equal to \_\_\_% of Plan Compensation.  
[Note: The combined Employer and Employee contribution must equal at least 7.5% of Plan Compensation.]
- (e) **Contributions of accrued sick, PTO and/or vacation leave.**
- (1) The Employer will make and allocate Employer Contributions of amounts of accrued unpaid sick leave as follows: \_\_\_\_\_
  - (2) The Employer will make and allocate Employer Contributions of amounts of accrued unpaid PTO leave as follows: \_\_\_\_\_
  - (3) The Employer will make and allocate Employer Contributions of amounts of accrued unpaid vacation leave as follows: \_\_\_\_\_
- (f) Describe Employer Contribution formula: \_\_\_\_\_

6-3 **ALLOCATION FORMULA.**

- (a) **Pro rata allocation.** The Employer Contribution under AA §6-2(a) will be allocated as:
  - (1) a uniform percentage of Plan Compensation or
  - (2) a uniform dollar amount
- (b) **Allocation under fixed Employer Contribution.** If a fixed Employer Contribution is selected in AA §6-2(b), the Employer Contribution will be allocated in accordance with the selections made in AA §6-2(b).
- (c) **Discretionary allocation.** The Employer Contribution under AA §6-2(a) will be allocated in the sole discretion of the Employer in a manner solely determined by the Employer.
- (d) **Service-based allocation.** The service-based Employer Contribution selected in AA §6-2(c) will be allocated in accordance with the selections made in AA §6-2(c).
- (e) **Describe other allocation method:** \_\_\_\_\_

6-4 **SPECIAL RULES.** No special rules apply with respect to Employer Contributions under the Plan, except to the extent designated under this AA §6-4.

- (a) **Period for determining Employer Contributions.** In determining the amount of the Employer Contributions to be allocated under this AA §6, the Employer Contribution will be based on Plan Compensation paid during the Plan Year, unless this (a) is selected and one of (1) – (4) is selected below.  
Alternatively, the Employer may elect to base the Employer Contributions on Plan Compensation paid during the following period:
    - (1) Plan Year quarter
    - (2) calendar month
    - (3) payroll period
    - (4) Other: \_\_\_\_\_
- [Note: Although Employer Contributions are determined on the basis of Plan Compensation paid during the period designated under this subsection (a), this does not require the Employer to actually make contributions or allocate contributions on the basis of such period.]

- (b) **Limit on Employer Contributions.** The Employer Contribution elected in AA §6-2 may not exceed:
  - (1) \_\_\_% of Plan Compensation
  - (2) \$\_\_\_
  - (3) Describe: \_\_\_\_\_
- (c) **Offset of Employer Contribution.**
  - (1) A Participant's allocation of Employer Contributions under AA §6-2 of this Plan is reduced by contributions under \_\_\_\_\_ [insert name of plan(s)].
  - (2) In applying the offset under this subsection, the following rules apply: \_\_\_\_\_
- (d) **Special rules.** The following special provisions apply with respect to Employer Contributions: \_\_\_\_\_

6-5 **ALLOCATION CONDITIONS.** A Participant who has otherwise satisfied all conditions to receive an Employer Contribution, must satisfy any allocation conditions designated under this AA §6-5 to receive an allocation of Employer Contributions under the Plan. [Note: The Plan may not impose allocation conditions on FICA Replacement Contributions.]

- (a) **No allocation conditions** apply with respect to Employer Contributions under the Plan.
- (b) **Employment condition.** An Employee must be employed with the Employer on the last day of the Plan Year.
- (c) **Minimum service condition.** An Employee must be credited with at least:
  - (1) \_\_\_ Hours of Service during the Plan Year.
  - (2) \_\_\_ consecutive days of employment with the Employer during the Plan Year.
  - (3) \_\_\_ consecutive months of employment with the Employer during the Plan Year.
- (d) **Application to a specified period.** The allocation conditions selected under this AA §6-5 apply on the basis of the Plan Year. Alternatively, if an employment or minimum service condition applies under this AA §6-5, the Employer may elect under this subsection to apply the allocation conditions on a periodic basis as set forth below. See Section 3.06(a) of the BPD for a description of the rules for applying the allocation conditions on a periodic basis.
  - (1) **Period for applying allocation conditions.** Instead of the Plan Year, the allocation conditions set forth under subsection (2) below apply with respect to the following periods:
    - (i) Plan Year quarter
    - (ii) calendar month
    - (iii) payroll period
    - (iv) Other: \_\_\_\_\_
  - (2) **Application to allocation conditions.** If this subsection (2) is checked to apply allocation conditions on the basis of specified periods, to the extent an employment or minimum service allocation condition applies under this AA §6-5, such allocation condition will apply based on the period selected under subsection (1) above, unless designated otherwise below:
    - (i) Only the employment condition will be based on the period selected in subsection (1) above.
    - (ii) Only the minimum service condition will be based on the period selected in subsection (1) above.
    - (iii) Describe any special rules: \_\_\_\_\_
- (e) **Exceptions.**
  - (1) The above allocation condition(s) will **not** apply if an Employee, during the Plan Year:
    - (i) dies.
    - (ii) has a Severance from Employment due to becoming Disabled.
    - (iii) becomes Disabled.
    - (iv) has a Severance from Employment after attaining Normal Retirement Age.
      - If this box is checked, this waiver of allocation conditions applies only once during the Participant's employment with the Employer. Thus, if an Employee is rehired after such a waiver was applied to such Employee, the waiver of allocation conditions will not apply to a subsequent Severance from Employment.
    - (v) has a Severance from Employment after attaining Early Retirement Age.
      - If this box is checked, this waiver of allocation conditions applies only once during the Participant's employment with the Employer. Thus, if an Employee is rehired after such a waiver was applied to such Employee, the waiver of allocation conditions will not apply to a subsequent Severance from Employment.
    - (vi) is on an authorized leave of absence from the Employer.

- (2) The exceptions selected under subsection (1) do not apply to:
    - (i) an employment condition designated under this AA §6-5.
    - (ii) a minimum service condition designated under this AA §6-5.
    - (iii) a Discretionary Employer Contribution.
    - (iv) a Fixed Employer Contribution.
  - (f) **Equivalency Method.** For purposes of determining an Employee's Hours of Service for allocation purposes, the Plan will use the Equivalency Method (as defined in Section 2.03(a)(4) of the BPD). The Equivalency Method will apply to:
    - (1) All Employees.
    - (2) Only Employees for whom the Employer does not maintain hourly records. For all other Employees, actual hours worked will be used.
  - (g) **Elapsed Time Method.** For purposes of determining an Employee's service for allocation purposes, the Plan will use the Elapsed Time Method.
  - (h) **Describe** any special rules governing the allocation conditions under the Plan: \_\_\_\_\_
- 6-6 **OPTIONAL TREATMENT OF EMPLOYER CONTRIBUTIONS AS ROTH CONTRIBUTIONS.** Unless elected otherwise below, a Participant may not elect to treat a nonforfeitable Employer Contribution made on behalf of such Participant as a Roth contribution.
- (a) A Participant MAY elect to treat a nonforfeitable Employer Contribution made on behalf of such Participant as a Roth contribution. [*Note: The Employer and/or Plan Administrator will develop operational procedures to assist in administering this election.*]
  - (b) Describe any special rules relating to the optional treatment of nonforfeitable Employer Contributions as a Roth contribution: \_\_\_\_\_
- 6-7 **SPECIAL RULES APPLICABLE TO EMPLOYER CONTRIBUTIONS.** The following special rules apply to Employer Contributions: \_\_\_\_\_

<b>SECTION 6A</b> <b>SALARY DEFERRALS</b>
--

- 6A-1 **SALARY DEFERRALS.** Are Employees permitted to make Salary Deferrals under the Plan?
- Yes
  - No [*If "No" is checked, skip to Section 6B.*]
- 6A-2 **MAXIMUM LIMIT ON SALARY DEFERRALS.** Unless designated otherwise under this AA §6A-2, a Participant may defer any amount up to the Code §457(e)(15) Maximum Contribution Limit.
- (a) **Salary Deferral Limit.** A Participant may not defer an amount in excess of:
    - (1) \_\_\_\_\_% of Plan Compensation.
    - (2) \$\_\_\_\_\_.

[*Note: If both (1) and (2) are checked, the deferral limit is the lesser of the amounts selected.*]

Any limit described in subsection (1) or (2) above applies with respect to the following period:

    - (3) Plan Year.
    - (4) the portion of the Plan Year during which the individual is eligible to participate.
    - (5) each separate payroll period during which the individual is eligible to participate.
  - (b) **Limits on Salary Deferrals on bonus payments.** [*Note: This §6A-2(b) only may be selected if bonus payments are not excluded under AA §5-3.*]
    - (1) The same limits specified in (a)(1) and (a)(2) above apply to bonus and non-bonus Plan Compensation. Employees may defer any amounts out of bonus payments, subject to the Code §457(e)(15) Maximum Contribution Limit and any other limit on Salary Deferrals under this AA 6A-2. The Employer may impose special limits on bonus payments under the Salary Deferral Election or in separate administrative procedures.
    - (2) A Participant may defer up to \_\_\_\_% (*not to exceed 100%*) of any bonus payment (subject to the Code §457(e)(15) Maximum Contribution Limit) without regard to any other limits described under this AA §6A-2. The Employer may impose special limits on bonus payments under the Salary Reduction Agreement election or in separate administrative procedures.

- (3) Describe special rules applicable to deferrals on bonus payments: \_\_\_\_\_
- (c) **Deferral of sick, vacation, PTO and back pay.** Unless otherwise elected below, a Participant may elect to defer accrued sick pay, accrued vacation pay, accrued PTO pay, or back pay if: (1) such pay is otherwise included in Plan Compensation; (2) the Participant timely enters into a Salary Reduction Agreement with respect to such pay; and (3) the Participant is an Employee in the month of deferral.
- A Participant may NOT defer accrued sick pay, accrued vacation pay, accrued PTO or back pay.
- (d) Describe any other limits that apply with respect to Salary Deferrals under the Plan: \_\_\_\_\_

6A-3 **MINIMUM DEFERRAL RATE.** Unless designated otherwise under this AA §6A-3, no minimum deferral requirement applies under the Plan. Alternatively, a Participant must defer at least the following amount in order to make Salary Deferrals under the Plan.

- (a) \_\_\_\_% of Plan Compensation for a payroll period.
- (b) \$\_\_\_\_ for a payroll period.
- (c) Describe. \_\_\_\_\_

6A-4 **CATCH-UP CONTRIBUTIONS.** Age 50 Catch-Up Contributions and Special 457 Catch-Up Contributions (as defined in Section 3.03(d) and (e) of the BPD) are permitted under the Plan, unless designated otherwise under this AA §6A-4.

- (a) Age 50 Catch-Up Contributions are not permitted under the Plan.
- (b) Special 457 Catch-Up Contributions are not permitted under the Plan.
- (c) Describe any special rules applicable to the Age 50 Catch-Up Contributions or Special 457 Catch-Up Contributions: \_\_\_\_\_

#### 6A-5 ROTH DEFERRALS.

- (a) **Availability of Roth Deferrals.**
- (1) Roth Deferrals are permitted under the Plan.
- (2) Roth Deferrals are not permitted under the Plan.
- [Note: If Roth Deferrals are effective as of a date later than the Effective Date of the Plan, designate such special Effective Date in AA §6A-8 below.]*
- (b) **Distribution of Roth Deferrals.** Unless designated otherwise under this subsection, to the extent a Participant takes a distribution or withdrawal from such Participant's Salary Deferral Account(s), the Participant may designate the extent to which such distribution is taken from the Pre-Tax Deferral Account or from the Roth Deferral Account. If a Participant fails to designate the Account, the Plan Administrator may distribute amounts pursuant to a separate administrative policy.
- Alternatively, the Employer may designate the order of distributions for the distribution types listed below:
- (1) **Distributions and withdrawals.**
- (i) Any distribution will be taken on a pro rata basis from the Participant's Pre-Tax Deferral Account and Roth Deferral Account.
- (ii) Any distribution will be taken first from the Participant's Roth Deferral Account and then from the Participant's Pre-Tax Deferral Account.
- (iii) Any distribution will be taken first from the Participant's Pre-Tax Deferral Account and then from the Participant's Roth Deferral Account.
- (2) **Distribution of Excess Deferrals.**
- (i) Distribution of Excess Deferrals will be made from Roth and Pre-Tax Deferral Accounts in the same proportion that deferrals were allocated to such Accounts for the calendar year.
- (ii) Distribution of Excess Deferrals will be made first from the Roth Deferral Account and then from the Pre-Tax Deferral Account.
- (iii) Distribution of Excess Deferrals will be made first from the Pre-Tax Deferral Account and then from the Roth Deferral Account.
- (c) **In-Plan Roth Conversions.** Unless elected under this AA §6A-5(e), the Plan does not permit a Participant to make an In-Plan Roth Conversion under the Plan. To override this provision to allow Participants to make an In-Plan Roth Conversion, subsection (1) must be checked.
- (1) **Effective date.** Effective February 11, 2026 [not earlier than 1/1/2013], a Participant may elect to convert all or any portion of such Participant's non-Roth vested Account Balance to an In-Plan Roth Conversion Account.

[*Note: The Plan must provide for Roth Deferrals under AA §6A-5(a) as of the effective date designated in this subsection (1). An election under this subsection (1) does not affect an In-Plan Roth Conversion that was allowed under prior Plan provisions.*]

(2) **In-Service Distribution.**

- (i) For a Participant to convert such Participant's eligible contributions to Roth through an In-Plan Roth Conversion, the Participant need not be eligible to take a distribution from the Plan. [*Note: If this subsection (i) is checked, a Participant may convert any or all of the eligible contribution sources to Roth Deferrals through an In-Plan Roth Conversion.*]
- (ii) For a Participant to convert such Participant's eligible contributions to Roth through an In-Plan Roth Conversion, a Participant must be eligible for a distribution of any amounts converted to Roth Deferrals through an In-Plan Roth Conversion. Thus, only amounts that are eligible for distribution under AA §9 are eligible for In-Plan Roth Conversion.

(3) **Contribution sources.** An Employee may elect to make an In-Plan Roth Conversion from all available contribution sources under the Plan. To override this default provision and limit the contribution sources available for In-Plan Roth Conversion, select the applicable contribution sources below:

- (i) Pre-tax Salary Deferrals
- (ii) Employer Contributions
- (iii) Matching Contributions
- (iv) Rollover Contributions
- (v) Describe: \_\_\_\_\_

(4) **Limits applicable to In-Plan Roth Conversions.** No special limits apply with respect to In-Plan Roth Conversions, unless designated otherwise under this subsection (4).

- (i) Roth conversions may only be made from contribution sources that are fully vested (i.e., 100% vested).
- (ii) A Participant may not make an In-Plan Roth Conversion of less than \$\_\_\_\_ (may not exceed \$1,000).
- (iii) A Participant may not make an In-Plan Roth Conversion of any outstanding loan amount.  
[*Note: If this subsection (iii) is not checked, a Participant may convert amounts that are attributable to an outstanding loan, to the extent the loan relates to a contribution source that is eligible for conversion under subsection (3) above.*]
- (iv) Only Participants who are current Employees are allowed to make In-Plan Roth Conversions.
- (v) The ability to make In-Plan Roth Conversions is limited to the following events: \_\_\_\_\_
- (vi) Describe: \_\_\_\_\_

(5) **Amounts available to pay federal and state taxes generated from an In-Plan Roth Conversion.** No special provisions apply to allow Participants to withdraw funds to pay federal or state taxes generated from an In-Plan Roth Conversion, except as provided otherwise under this subsection (5).

- (i) **In-service distribution.** If the Plan does not otherwise permit an in-service distribution at the time of the In-Plan Roth Conversion and this subsection (i) is checked, a Participant may elect to take an in-service distribution solely to pay taxes generated from the In-Plan Roth Conversion to the extent such in-service distribution would otherwise be permitted under Section 8.03 of the BPD.  
[*Note: If this subsection (i) is checked, a Participant may take an in-service distribution only to the extent such distribution would otherwise be permitted under the provisions of Section 8.03 of the BPD.*]
- (ii) **Participant loan.** Generally, a Participant may request a loan from the Plan to the extent permitted under Section 13 of the BPD and AA Appendix B. However, to the extent a Participant loan is not otherwise allowed and this subsection (ii) is selected, a Participant may receive a Participant loan solely to pay taxes generated from an In-Plan Roth Conversion.  
[*Note: If this subsection (ii) is selected and Participant loans are not otherwise authorized under the Plan, any Participant loan made pursuant to this subsection (ii) will be made in accordance with the default loan policy described in Section 13 of the BPD.*]

(6) **Distribution from In-Plan Roth Conversion Account.** Distributions from the In-Plan Roth Conversion Account will be permitted in the same manner as permitted for Roth Deferrals, as set forth under AA §9-2, unless designated otherwise under this subsection (6).

Describe distribution options: \_\_\_\_\_

(d) **Describe** any special rules that apply to Roth Deferrals under the Plan: \_\_\_\_\_

6A-6 SALARY REDUCTION AGREEMENT ELECTIONS.

- (a) **Change or revocation of Salary Reduction Agreement election:** A Participant's election to change or resume a Salary Reduction Agreement election will be effective as set forth under the Salary Reduction Agreement or other written procedures adopted by the Plan Administrator. Unless the Salary Reduction Agreement or other written procedures adopted by the Plan Administrator provide otherwise, a Participant may revoke a Salary Reduction Agreement election (on a prospective basis) at any time.
- (b) **Salary deferral elections of rehired participants:** Unless designated otherwise below, a Participant's affirmative Salary Reduction Agreement to defer (or to not defer) will cease upon Severance from Employment and the Participant will need to make a new election upon rehire.
- Participant's affirmative election does not cease upon Severance from Employment.** If this subsection (b) is selected, a terminated Participant's affirmative Salary Reduction Agreement election to defer (or to not defer) **will not cease** upon Severance from Employment and the Participant's affirmative Salary Reduction Agreement election to defer (or to not defer) in effect at the time of Severance from Employment will apply upon rehire.
- [Note: The Employer may modify the rules applicable to rehired Employees under the Salary Reduction Agreement or other administrative procedures.]*

6A-7 AUTOMATIC CONTRIBUTION ARRANGEMENT. No automatic contribution provisions apply under Section 3.03(c) of the BPD, unless provided otherwise under this AA §6A-7. *[Note: Some States through anti-garnishment laws or otherwise may not allow Automatic Contribution Arrangements.]*

- (a) **Automatic deferral election.** Upon becoming eligible to make Salary Deferrals under the Plan (pursuant to AA §3 and AA §4), a Participant will be deemed to have entered into a Salary Deferral Election for each payroll period, unless the Participant completes a Salary Reduction Agreement election (subject to the limitations under AA §6A-2 and AA §6A-3) in accordance with procedures adopted by the Plan Administrator.
- (1) **Effective date of Automatic Contribution Arrangement.** The automatic deferral provisions under this AA §6A-7 are effective as of:
- (i) The Effective Date of this Plan as set forth under the Employer Signature Page.
- (ii) \_\_\_\_\_ *[insert date]*
- (iii) As set forth under a prior Plan document.
- [Note: If this subsection (iii) is checked, the automatic deferral provisions under this AA §6A-7 will apply as of the original Effective Date of the automatic contribution arrangement. Unless provided otherwise under this AA §6A-7, an Employee who is automatically enrolled under a prior Plan document will continue to be automatically enrolled under the current Plan document.]*
- (2) **Automatic Contribution Arrangement.** Check this subsection (2) if the Plan is designated as an Automatic Contribution Arrangement, as described under Section 3.03(c) of the BPD. *[Note: Unless an election is made under this AA §6A-7 that is inconsistent with the requirements of an Eligible Automatic Contribution Arrangement (EACA), the Automatic Contribution Arrangement will qualify as an EACA, as described in Section 3.03(c) of the BPD.]*
- (i) **Automatic Contribution Arrangement features determined under separate administrative procedures.** The Employer has described the features of its Automatic Contribution Arrangement in a separate administrative policy which is incorporated by reference into this Plan. To the extent that either (ii) or (iii) below is not completed, those features of the Automatic Contribution Arrangement will be determined by the terms of a separate administrative policy.
- (ii) **Automatic deferral percentage.**
- (A) \_\_\_% of Plan Compensation
- (B) \$\_\_\_
- (iii) **Automatic increase.** If elected under this subsection (iii), the automatic deferral amount will increase each Plan Year by the following amount. (See Section 3.03(c) of the BPD.)
- (A) \_\_\_% of Plan Compensation
- (B) \$\_\_\_
- (C) Describe: \_\_\_\_\_
- Any automatic increase elected under this subsection (iii) will not cause the automatic deferral amount to exceed:
- (D) \_\_\_% of Plan Compensation
- (E) \$\_\_\_
- (F) Describe: \_\_\_\_\_

- (3) **Application of automatic deferral provisions.** The automatic deferral election under subsection (2) will apply to new Participants and existing Participants as set forth under this subsection (3).
- (i) **New Participants.** The automatic deferral provisions apply to all Participants who become eligible on or after the effective date.
- (ii) **Current Participants.** The automatic deferral provisions apply to all other eligible Participants as follows:
- (A) Automatic deferral provisions apply to all current Participants who have not entered into a Salary Deferral Election (including an election not to defer under the Plan).
- (B) Automatic deferral provisions apply to all current Participants who have not entered into a Salary Deferral Election that is at least equal to the automatic deferral amount under subsection (2)(ii). Current Participants who have made a Salary Deferral Election that is less than the automatic deferral amount or who have not made a Salary Deferral Election will automatically be increased to the automatic deferral amount unless the Participant enters into a new Salary Deferral election on or after the effective date of the automatic deferral provisions.
- (C) Automatic deferral provisions do not apply to current Participants. Only new Participants described in subsection (i) above are subject to the automatic deferral provisions.
- (D) Describe: \_\_\_\_\_
- (iii) **Treatment of automatic deferrals.** Any Salary Deferrals made pursuant to an automatic deferral election will be treated as Pre-Tax Salary Deferrals, unless designated otherwise under this subsection (iii).
- Any Salary Deferrals made pursuant to an automatic deferral election will be treated as Roth Deferrals. [*Note: This subsection (iii) may only be checked if Roth Deferrals are permitted under AA §6A-5.*]
- (iv) **Expiration of affirmative deferral elections.** Unless this subsection (iv) is elected, for purposes of the automatic deferral provisions of the Plan, a Participant's affirmative elective deferral election will not expire. If this subsection (iv) is elected, a Participant's affirmative deferral election will expire:
- (A) at the end of each Plan Year.
- (B) Describe date that the affirmative election will expire: \_\_\_\_\_
- If a Participant fails to complete a new affirmative deferral election subsequent to the prior election expiring, the Participant becomes subject to the automatic deferral percentage as specified in the Plan pursuant to the automatic contribution arrangement provisions. Each year, the Participant can always complete a new affirmative election and designate a new deferral percentage.
- [*Note: Any Salary Deferral Election (including an election not to defer under the Plan) made after the effective date of the automatic deferral provisions will override such automatic deferral provisions.*]
- (4) **Application of automatic increase.** Unless designated otherwise under this subsection (4), if an automatic increase is selected under subsection (2)(iii) above, the automatic increase will take effect as of the first day of the second Plan Year following the Plan Year in which the automatic deferral election first becomes effective with respect to a Participant. (See Section 3.03(c)(2)(iii) of the BPD.)
- (i) **First Plan Year.** Instead of applying as of the second Plan Year, the automatic increase described in subsection (2)(iii) takes effect as of the appropriate date (as designated under subsection (iii) below) within the first Plan Year following the date automatic contributions begin.
- (ii) **Designated Plan Year.** Instead of applying as of the second Plan Year, the automatic increase described in subsection (2)(iii) takes effect as of the appropriate date (as designated under subsection (iii) below) within the \_\_\_\_\_ Plan Year following the Plan Year in which the automatic deferral election first becomes effective with respect to a Participant.
- (iii) **Effective date.** The automatic increase described under subsection (2)(iii) is generally effective as of the first day of the Plan Year. If this subsection (iii) is checked, instead of becoming effective on the first day of the Plan Year, the automatic increase will be effective on:
- (A) The anniversary of the Participant's date of hire.
- (B) The anniversary of the Participant's first automatic deferral contribution.
- (C) The first day of each calendar year.
- (D) Other date: \_\_\_\_\_
- (iv) **Special rules:** \_\_\_\_\_

- (5) **Treatment of Employees who have a Severance from Employment and who are rehired.** Unless designated otherwise below, in applying the automatic deferral provisions under this AA §6A-7, including the automatic increase provisions, a rehired Participant is treated as a new Employee (regardless of the amount of time since the rehired Employee had a Severance from Employment).
- (i) **Rehired Employees not treated as new Employee.** In applying the automatic deferral provisions under this AA §6A-7, including the automatic increase provisions, a rehired Participant is not treated as a new Employee. Thus, for example, a rehired Participant's deferral percentage will be calculated based on the date the individual first began making automatic deferrals under the Plan.
  - (ii) **Describe special rules applicable to rehired employees:** \_\_\_\_\_
- (b) **Permissible Withdrawals under Automatic Contribution Arrangement.**
- (1) **Permissible withdrawals allowed.** If the Plan satisfies the requirements for an EACA (as set forth in Section 3.03(c) of the BPD), a Participant who has Salary Deferrals contributed to the Plan pursuant to an automatic deferral election under this AA §6A-7 may elect to withdraw such contributions (and earnings attributable thereto) within 90 days after the date such Salary Deferrals would otherwise have been included in gross income, unless designated otherwise under subsection (3) below. Unless elected otherwise below, if a Participant does not make automatic deferrals to the Plan for an entire Plan Year (e.g., due to Severance from Employment), the Plan may allow such Participant to take a permissive withdrawal, but only with respect to default contributions made after the Participant's return to employment.
    - The ability to take permissible withdrawals does not apply to rehired Participants, even if such Participants have not made automatic deferrals to the Plan for an entire Plan Year due to Severance from Employment.
  - (2) **No permissible withdrawals.** Although the Plan contains an automatic deferral election that is designed to satisfy the requirements of an EACA, the permissible withdrawal provisions under this subsection (b) are not available.
  - (3) **Time period for electing a permissible withdrawal.** Instead of a 90-day election period, a Participant must request a permissible withdrawal no later than \_\_\_\_ [may not be less than 30 or more than 90] days after the date the Plan Compensation from which such Salary Deferrals are withheld would otherwise have been included in gross income.
- (c) **Other automatic contribution provisions:** \_\_\_\_\_

6A-8 **SPECIAL DEFERRAL EFFECTIVE DATES.** Unless designated otherwise under this AA §6A-8, a Participant is eligible to make Salary Deferrals under the Plan as of the Effective Date of the Plan (as designated in the Employer Signature Page). However, in no case may a Participant begin making Salary Deferrals prior to the later of the date the Employee becomes a Participant, the date the Participant executes a Salary Reduction Agreement or the date the Plan is adopted or effective. (See Section 3.03(a) of the BPD.)

To designate a later Effective Date for Salary Deferrals or Roth Deferrals, complete this AA §6A-8.

- (a) **Salary Deferrals.** A Participant is eligible to make Salary Deferrals under the Plan as of:
  - (1) the date the Plan is executed by the Employer (as indicated on the Employer Signature Page).
  - (2) \_\_\_\_ (insert date).
- (b) **Roth Deferrals.** The Roth Deferral provisions under AA §6A-5 are effective as of \_\_\_\_\_. [Note: If Roth Deferrals are permitted under AA §6A-5 above, Roth Deferrals are effective as of the Effective Date applicable to Salary Deferrals under this AA §6A-8, unless a later date is designated under this subsection.]

<b>SECTION 6B</b> <b>MATCHING CONTRIBUTIONS</b>
--

6B-1 **MATCHING CONTRIBUTIONS.** Is the Employer authorized to make Matching Contributions under the Plan?

- Yes
- No [Check this box if there are no Matching Contributions. If "No" is checked, skip to Section 7.]

[Note: Any Matching Contribution made pursuant to this AA §6B will count towards the Code §457(e)(15) Maximum Contribution Limit. See Section 5.01 of the BPD.]

6B-2 **MATCHING CONTRIBUTION FORMULA:** For the period designated in AA §6B-5 below, the Employer will make the following Matching Contribution on behalf of Participants who satisfy the allocation conditions under AA §6B-6 below.

- (a) **Discretionary match.** The Employer will determine in its sole discretion how much, if any, it will make as a Matching Contribution and how such Matching Contribution is allocated to Participants.

- (b) **Fixed match.** The Employer will make a Matching Contribution for each Participant equal to:
- (1) \_\_\_% of Salary Deferrals made for each period designated in AA §6B-5 below.
  - (2) \$\_\_\_ for each period designated in AA §6B-5 below.
  - (3) The Employer Contribution will be determined in accordance with the personal service contract or employment contract applicable to the Participant.
  - (4) The Employer Contribution will be determined in accordance with any Collective Bargaining Agreement(s) addressing retirement benefits of Collectively Bargained Employees under the Plan.
- (c) **Tiered match.** The Employer will/may make a Fixed/Discretionary Matching Contribution to all Participants based on the following tiers of Salary Deferrals.

- (1) **Tiers as percentage of Plan Compensation.**

Salary Deferrals	Fixed Match	Discretionary Match
<input type="checkbox"/> (i) Up to ___% of Plan Compensation	_____%	<input type="checkbox"/>
<input type="checkbox"/> (ii) From ___% up to ___% of Plan Compensation	_____%	<input type="checkbox"/>
<input type="checkbox"/> (iii) From ___% up to ___% of Plan Compensation	_____%	<input type="checkbox"/>
<input type="checkbox"/> (iv) From ___% up to ___% of Plan Compensation	_____%	<input type="checkbox"/>

- (2) **Tiers as dollar amounts.**

Salary Deferrals	Fixed Match	Discretionary Match
<input type="checkbox"/> (i) Up to \$___	_____%	<input type="checkbox"/>
<input type="checkbox"/> (ii) From \$___ up to \$___	_____%	<input type="checkbox"/>
<input type="checkbox"/> (iii) From \$___ up to \$___	_____%	<input type="checkbox"/>
<input type="checkbox"/> (iv) Above \$___	_____%	<input type="checkbox"/>

- (d) **Year of Service match.** The Employer will/may make a fixed %/Discretionary Matching Contribution as a uniform percentage of Salary Deferrals to all Participants based on Years of Service with the Employer.

Years of Service	Matching %	Discretionary Match
<input type="checkbox"/> (1) From ___ up to ___ Years of Service	_____%	<input type="checkbox"/>
<input type="checkbox"/> (2) From ___ up to ___ Years of Service	_____%	<input type="checkbox"/>
<input type="checkbox"/> (3) From ___ up to ___ Years of Service	_____%	<input type="checkbox"/>
<input type="checkbox"/> (4) From ___ up to ___ Years of Service	_____%	<input type="checkbox"/>
<input type="checkbox"/> (5) Years of Service equal to and above ___	_____%	<input type="checkbox"/>

For this purpose, a Year of Service is each Plan Year during which an Employee completes at least 1,000 Hours of Service. Alternatively, a Year of Service is: \_\_\_\_\_

- (e) **Other Matching Contribution Formula:** \_\_\_\_\_

6B-3 **CONTRIBUTIONS ELIGIBLE FOR MATCHING CONTRIBUTIONS (“ELIGIBLE CONTRIBUTIONS”).** Unless designated otherwise under this AA §6B-3, all Salary Deferrals, including any Roth Deferrals, Age 50 Catch-Up Contributions and Special 457 Catch-Up Contributions, are eligible for the Matching Contributions designated under AA §6B-2.

- (a) **Matching Contributions.** Only the following contribution sources are eligible for a Matching Contribution under AA §6B-2:
- (1) Pre-tax Salary Deferrals
  - (2) Roth Deferrals
  - (3) Age 50 Catch-Up Contributions
  - (4) Special 457 Catch-Up Contributions

- (b) **Application of Matching Contributions to elective deferrals made under another plan maintained by the Employer.** If this subsection is checked, the Matching Contributions described in AA §6B-2 will apply to elective deferrals made under another plan maintained by the Employer.
- (1) The Matching Contribution designated in AA §6B-2 above will apply to elective deferrals under the following plan maintained by the Employer: \_\_\_\_\_
- (2) The following special rules apply in determining the amount of Matching Contributions under this Plan with respect to elective deferrals under the plan described in subsection (1): \_\_\_\_\_
- [Note: This subsection may be used to describe special provisions applicable to Matching Contributions provided with respect to elective deferrals under another plan maintained by the Employer, including another Code §457(b) plan, a §401(a) qualified plan, or Code §403(b) plan.]
- (c) **Special rules.** The following special rules apply for purposes of determining the Matching Contribution under this AA §6B-3: \_\_\_\_\_

6B-4 **LIMITS ON MATCHING CONTRIBUTIONS.** In applying the Matching Contribution formula(s) selected under AA §6B-2 above, the following limits apply.

- (a) **No limits apply.** All Salary Deferrals are eligible for Matching Contributions.
- (b) **Limit on Salary Deferrals.** The Matching Contribution formula(s) selected in AA §6B-2 above apply only to Salary Deferrals that do not exceed:
- (1) \_\_\_\_\_% of Plan Compensation.
- (2) \$\_\_\_\_\_.
- (3) A discretionary amount determined by the Employer.
- (c) **Limit on Matching Contributions.** The total Matching Contribution provided under the formula(s) selected in AA §6B-2 above will not exceed:
- (1) \_\_\_\_\_% of Plan Compensation.
- (2) \$\_\_\_\_\_.
- (d) **Special limits:** \_\_\_\_\_

6B-5 **PERIOD FOR DETERMINING MATCHING CONTRIBUTIONS.** The Matching Contribution formula(s) selected in AA §6B-2 above (including any limitations on such amounts under AA §6B-4) are based on Salary Deferrals for the **Plan Year**. To apply a different period for determining the Matching Contributions and limits under AA §6B-2 and AA §6B-4, check one of (a) – (d) below.

- (a) payroll period  (b) Plan Year quarter
- (c) calendar month  (d) Other: \_\_\_\_\_

[Note: Although Matching Contributions (and any limits on those Matching Contributions) will be determined on the basis of the period designated under this AA §6B-5, this does not require the Employer to actually make contributions or allocate contributions on the basis of such period. See Section 3.04(c) of the BPD for a discussion of the “true up” requirements applicable to Matching Contributions.]

6B-6 **ALLOCATION CONDITIONS.** A Participant who has otherwise satisfied all conditions to receive a Matching Contribution, must satisfy any allocation conditions designated under this AA §6B-6 to receive an allocation of Matching Contributions under the Plan.

- (a) **No allocation conditions** apply with respect to Matching Contributions under the Plan.
- (b) **Employment condition.** An Employee must be employed with the Employer on the last day of the Plan Year.
- (c) **Minimum service condition.** An Employee must be credited with at least:
- (1) \_\_\_\_\_ Hours of Service during the Plan Year.
- (2) \_\_\_\_\_ consecutive days of employment with the Employer during the Plan Year.
- (3) \_\_\_\_\_ consecutive months of employment with the Employer during the Plan Year.
- (d) **Application to a specified period.** The allocation conditions selected under this AA §6B-6 apply on the basis of the Plan Year. Alternatively, if an employment or minimum service condition applies under this AA §6B-6, the Employer may elect under this subsection to apply the allocation conditions on a periodic basis as set forth below. (See Section 3.06(a) of the BPD for a description of the rules for applying the allocation conditions on a periodic basis.)
- (1) **Period for applying allocation conditions.** Instead of the Plan Year, the allocation conditions set forth under subsection (2) below apply with respect to the following periods:
- (i) Plan Year quarter
- (ii) calendar month

- (iii) payroll period
- (iv) Other: \_\_\_\_\_
- (2) **Application to allocation conditions.** To the extent an employment or minimum service allocation condition applies under this AA §6B-6, such allocation condition will apply based on the period selected under subsection (1) above, unless designated otherwise below:
  - (i) Only the employment condition will be based on the period selected in subsection (1) above.
  - (ii) Only the minimum service condition will be based on the period selected in subsection (1) above.
  - (iii) Describe any special rules: \_\_\_\_\_
- (c) **Exceptions.**
  - (1) The above allocation condition(s) will **not** apply if the Employee, during the Plan Year:
    - (i) dies.
    - (ii) has a Severance from Employment due to becoming Disabled.
    - (iii) becomes Disabled.
    - (iv) has a Severance from Employment after attaining Normal Retirement Age.
      - If this box is checked, this waiver of allocation conditions applies only once during the Participant's employment with the Employer. Thus, if an Employee is rehired after such a waiver was applied to such Employee, the waiver of allocation conditions will not apply to a subsequent Severance from Employment.
    - (v) has a Severance from Employment after attaining Early Retirement Age.
      - If this box is checked, this waiver of allocation conditions applies only once during the Participant's employment with the Employer. Thus, if an Employee is rehired after such a waiver was applied to such Employee, the waiver of allocation conditions will not apply to a subsequent Severance from Employment.
    - (vi) is on an authorized leave of absence from the Employer.
  - (2) The exceptions selected under subsection (1) do not apply to:
    - (i) an employment condition designated under this AA §6B-6.
    - (ii) a minimum service condition designated under this AA §6B-6.
    - (iii) a Discretionary Matching Contribution.
    - (iv) a Fixed Matching Contribution.
- (f) **Equivalency Method.** For purposes of determining an Employee's Hours of Service for allocation purposes, the Plan will use the Equivalency Method (as defined in Section 2.03(a)(4) of the BPD). The Equivalency Method will apply to:
  - (1) All Employees.
  - (2) Only Employees for whom the Employer does not maintain hourly records. For Employees for whom the Employer maintains hourly records, eligibility will be determined based on actual hours worked.
- (g) **Elapsed Time Method.** For purposes of determining an Employee's service for allocation purposes, the Plan will use the Elapsed Time Method
- (h) **Describe any special rules governing the allocation conditions under the Plan:** \_\_\_\_\_

6B-7 **OPTIONAL TREATMENT OF MATCHING CONTRIBUTIONS AS ROTH CONTRIBUTIONS.** Unless elected otherwise below, a Participant may not elect to treat a nonforfeitable Matching Contribution made on behalf of such Participant as a Roth Deferrals.

- (a) A Participant MAY elect to treat a nonforfeitable Matching Contribution made on behalf of such Participant as a Roth Deferral. [*Note: The Employer and/or Plan Administrator will develop operational procedures to assist in administering this election.*]
- (b) Describe special any special rules relating to the optional treatment of nonforfeitable Matching Contributions as a Roth Deferral: \_\_\_\_\_

6B-8 **OPTIONAL TREATMENT OF QUALIFIED STUDENT LOAN PAYMENTS AS SALARY DEFERRALS FOR MATCHING CONTRIBUTIONS.** Unless elected otherwise below, Qualified Student Loan Payments are not treated as Salary Deferrals for Matching Contribution purposes under the Plan.

- (a) Effective \_\_\_\_ (no earlier than the first day of the Plan Year beginning after December 31, 2023), the Employer elects to make Matching Contributions on account of Qualified Student Loan Payments, as provided under BPD Section 3.04(c). The Employer may develop procedures to assist in the administration of this election and/or may specify any special rules under subsection (b) below.

- (b) Describe any special rules applicable to the optional treatment of Qualified Student Loan Payments as Salary Deferrals for Matching Contribution purposes: \_\_\_\_\_

6B-9 **SPECIAL RULES APPLICABLE TO MATCHING CONTRIBUTIONS.** The following special rules apply to Matching Contributions: \_\_\_\_\_

**SECTION 7  
RETIREMENT AGES**

7-1 **NORMAL RETIREMENT AGE.** For purposes of applying the Special 457 Catch-Up Contribution under AA §6A-4(b) (and vesting, allocation and other provisions of the Plan referring to Normal Retirement Age, if applicable), Normal Retirement Age under the Plan is:

- (a) Age \_\_\_\_ (not earlier than age 65 or later than age 70 ½).
- (b) The earlier of age \_\_\_\_ (not earlier than age 65 or later than age 70 ½) or the date immediate retirement benefits are authorized under a pension plan maintained by the Employer (as set forth under Section 5.04(b) of the BPD).
- (c) The Participant may designate a Normal Retirement Age that is on or after the earlier of age 65 or the date immediate retirement benefits are authorized under a pension plan maintained by the Employer (as set forth under Section 5.04(b) of the BPD) but not later than age 70½.
- (d) The Participant may designate a Normal Retirement Age that is on or after age \_\_\_\_ (not earlier than age 65) but not later than age \_\_\_\_ (not later than age 70½).
- (e) Describe Normal Retirement Age: \_\_\_\_\_

**Normal Retirement Age for Qualified Police (elect if applicable):**

- (f) Age \_\_\_\_ (not earlier than age 40 or later than age 70 ½).
- (g) The earlier of age \_\_\_\_ (not earlier than age 40 or later than age 70 ½) or the date immediate retirement benefits are authorized under a pension plan maintained by the Employer (as set forth under Section 5.04(c) of the BPD).
- (h) The Participant may designate a Normal Retirement Age that is on or after the earlier of age 40 or the date immediate retirement benefits are authorized under a pension plan maintained by the Employer (as set forth under Section 5.04(b) of the BPD) but not later than age 70½.
- (i) The Participant may designate a Normal Retirement Age that is on or after age 65 but not later than age 70½.
- (j) Describe Normal Retirement Age for Qualified Police: \_\_\_\_\_

**Normal Retirement Age for Firefighters (elect if applicable):**

- (k) Age \_\_\_\_ (not earlier than age 40 or later than age 70 ½).
- (l) The earlier of age \_\_\_\_ (not earlier than age 40 or later than age 70 ½) or the date immediate retirement benefits are authorized under a pension plan maintained by the Employer (as set forth under Section 5.04(c) of the BPD).
- (m) The Participant may designate a Normal Retirement Age that is on or after the earlier of age 40 or the date immediate retirement benefits are authorized under a pension plan maintained by the Employer (as set forth under Section 5.04(b) of the BPD) but not later than age 70½.
- (n) The Participant may designate a Normal Retirement Age that is on or after age 65 but not later than age 70½.
- (o) Describe Normal Retirement Age for Firefighters: \_\_\_\_\_

[Note: A Participant's Normal Retirement Age must be the same as such Participant's normal retirement age under any other 457(b) plans sponsored by the Employer. The designation of a Normal Retirement Age under the Plan does not compel retirement with the Employer.]

**SECTION 8  
VESTING AND FORFEITURES**

8-1 **CONTRIBUTIONS SUBJECT TO VESTING.** Does the Plan provide for Employer Contributions under AA §6 or Matching Contributions under AA §6B that are subject to vesting?

- Yes
- No [If "No" is checked, skip to Section 9.]

*[Note: The imposition of a vesting schedule creates a substantial risk of forfeiture with respect to the contributions subject to the vesting schedule. If a contribution is subject to a substantial risk of forfeiture, such contribution is not counted toward the Maximum Contribution Limit until the substantial risk of forfeiture lapses (i.e., the contributions are vested). Where an amount is subject to a substantial risk of forfeiture, gains or losses allocable to the amount deferred, through the date that the substantial risk of forfeiture lapses, are taken into account in determining the amount that is considered deferred in the year in which the substantial risk of forfeiture lapses.]*

**8-2 VESTING SCHEDULE.** The vesting schedule under the Plan is as follows for both Employer Contributions and Matching Contributions, to the extent authorized under AA §6 and AA §6B. See Section 7.02(a) of the BPD for a description of the various vesting schedules under this AA §8-2. (Note: If the Employer imposes a vesting schedule, Employer Contributions and Matching Contributions, and attributable earnings, will count towards the Code §457(c)(15) Maximum Contribution Limit for the year in which the amounts become vested.)

ER	Match	
<input type="checkbox"/>	<input type="checkbox"/>	(a) Full and immediate vesting.
<input type="checkbox"/>	<input type="checkbox"/>	(b) 3-year cliff vesting schedule
<input type="checkbox"/>	<input type="checkbox"/>	(c) 6-year graded vesting schedule
<input type="checkbox"/>	<input type="checkbox"/>	(d) Modified vesting schedule
		___% immediately on Plan participation
		___% after 1 Year of Service
		___% after 2 Years of Service
		___% after 3 Years of Service
		___% after 4 Years of Service
		___% after 5 Years of Service
		100% after 6 Years of Service
<input type="checkbox"/>	<input type="checkbox"/>	(e) Other: _____

**8-3 VESTING SERVICE.** In applying the vesting schedules under this AA §8, the following service with the Employer is excluded.

- (a) None, all service with the Employer counts for vesting purposes.
- (b) Service before the original Effective Date of this Plan is excluded. (See Section 7.06 of the BPD for rules regarding Predecessor Service.)
- (c) Service completed before the Employee's \_\_\_ birthday is excluded.

**8-4 FULL VESTING.** An Employee's vesting percentage increases to 100% if, while employed with the Employer, the Employee:

- (a) dies.
- (b) has a Severance from Employment due to becoming Disabled.
- (c) becomes Disabled.
- (d) attains Normal Retirement Age.
- (e) Other: \_\_\_\_\_
- (f) Not applicable. No increase in vesting applies.

**8-5 DEFAULT VESTING RULES.** In applying the vesting requirements under this AA §8, the following default rules apply.

- **Year of Service.** An Employee earns a Year of Service for vesting purposes upon completing 1,000 Hours of Service during a Vesting Computation Period. Hours of Service are calculated based on actual hours worked during the Vesting Computation Period.
- **Vesting Computation Period.** The Vesting Computation Period is the Plan Year.

To override the default vesting rules, complete the applicable sections of this AA §8-5. If this AA §8-5 is not completed, the default vesting rules apply.

- | ER                       | Match                    |   |
|--------------------------|--------------------------|---|
| <input type="checkbox"/> | <input type="checkbox"/> | (a) <b>Year of Service.</b> Instead of 1,000 Hours of Service, an Employee earns a Year of Service upon the completion of ____ [ <i>must be less than 1,000</i> ] Hours of Service during a Vesting Computation Period.   |
| <input type="checkbox"/> | <input type="checkbox"/> | (b) <b>Vesting Computation Period.</b> Instead of the Plan Year, the Vesting Computation Period is: <ul style="list-style-type: none"> <li><input type="checkbox"/> (1) The 12-month period beginning with the anniversary of the Employee’s date of hire.</li> <li><input type="checkbox"/> (2) Describe: _____</li> </ul> [ <i>Note: Any Vesting Computation Period described in (2) must be a 12-consecutive month period and must apply uniformly to all Participants.</i> ]  |
| <input type="checkbox"/> | <input type="checkbox"/> | (c) <b>Elapsed Time Method.</b> Vesting service will be determined under the Elapsed Time Method. (See Section 7.03(b) of the BPD.)   |
| <input type="checkbox"/> | <input type="checkbox"/> | (d) <b>Equivalency Method.</b> For purposes of determining an Employee’s Hours of Service for vesting, the Plan will use the Equivalency Method (as defined in Section 7.03(a)(2) of the BPD). The Equivalency Method will apply to: <ul style="list-style-type: none"> <li><input type="checkbox"/> (1) All Employees.</li> <li><input type="checkbox"/> (2) Employees who are not paid on an hourly basis. For Employees paid on an hourly basis, vesting will be determined based on actual hours worked.</li> </ul> If this (d) is checked, Hours of Service for vesting will be determined under the following Equivalency Method. <ul style="list-style-type: none"> <li><input type="checkbox"/> (3) <b>Monthly.</b> 190 Hours of Service for each month worked.</li> <li><input type="checkbox"/> (4) <b>Weekly.</b> 45 Hours of Service for each week worked.</li> <li><input type="checkbox"/> (5) <b>Daily.</b> 10 Hours of Service for each day worked.</li> <li><input type="checkbox"/> (6) <b>Semi-monthly.</b> 95 Hours of Service for each semi-monthly period.</li> <li><input type="checkbox"/> (7) <b>Hours worked.</b> 870 hours worked treated as 1,000 Hours of Service and 435 hours worked treated as 500 Hours of Service.</li> <li><input type="checkbox"/> (8) <b>Regular time hours.</b> 750 regular time hours treated as 1,000 Hours of Service and 375 regular time hours treated as 500 Hours of Service.</li> </ul> |

8-6 **ALLOCATION OF FORFEITURES.** The Employer may decide in its discretion how to treat forfeitures under the Plan. Alternatively, the Employer may designate under this AA §8-6 how forfeitures occurring during a Plan Year will be treated. [*Note: No elections are required under this AA §8-6, if the Employer decides to use its discretion on how to treat forfeitures.*]

Any forfeitures occurring during a Plan Year will be:

- | ER                       | Match                    |  |
|--------------------------|--------------------------|--|
| <input type="checkbox"/> | <input type="checkbox"/> | (a) N/A. All contributions are 100% vested. [ <i>Do not complete the rest of this AA §8-6.</i> ] |
| <input type="checkbox"/> | <input type="checkbox"/> | (b) Reallocated as additional Employer Contributions or as additional Matching Contributions.    |
| <input type="checkbox"/> | <input type="checkbox"/> | (c) Used to reduce Employer and/or Matching Contributions.                                       |

For purposes of subsection (b) or (c), forfeitures will be applied:

- |                          |                          |   |
|--------------------------|--------------------------|---|
| <input type="checkbox"/> | <input type="checkbox"/> | (d) for the Plan Year in which the forfeiture occurs.                         |
| <input type="checkbox"/> | <input type="checkbox"/> | (e) for the Plan Year following the Plan Year in which the forfeitures occur. |

Prior to applying forfeitures under subsection (b) or (c):

- |                          |                          |   |
|--------------------------|--------------------------|---|
| <input type="checkbox"/> | <input type="checkbox"/> | (f) Forfeitures may be used to pay Plan expenses. (See Section 7.08(c) of the BPD.) |
| <input type="checkbox"/> | <input type="checkbox"/> | (g) Forfeitures may not be used to pay Plan expenses.                               |

In determining the amount of forfeitures to be reallocated under subsection (b), the same allocation conditions apply as for the source for which the forfeiture is being allocated under AA §6-5 or AA §6B-6, unless designated otherwise below.

- |                          |                          |   |
|--------------------------|--------------------------|---|
| <input type="checkbox"/> | <input type="checkbox"/> | (h) Forfeitures are not subject to any allocation conditions.                 |
| <input type="checkbox"/> | <input type="checkbox"/> | (i) Forfeitures are subject to a last day of employment allocation condition. |

**ER                      Match**

                                           (j) Forfeitures are subject to a \_\_\_\_ Hours of Service minimum service requirement.

In determining the treatment of forfeitures under this AA §8-6, the following special rules apply:

                                           (k) Describe: \_\_\_\_\_

**8-7 SPECIAL RULES REGARDING CASH-OUT DISTRIBUTIONS.**

(a) **Additional allocations.** If a Participant who has a Severance from Employment receives a complete distribution of such Participant's vested Account Balance while still entitled to an additional allocation, the forfeiture provisions do not apply until the Participant receives a distribution of the additional amounts to be allocated.

To modify the default forfeiture rules, complete this AA §8-7(a).

                     The forfeiture provisions will apply if a Participant who has a Severance from Employment takes a complete distribution, regardless of any additional allocations during the Plan Year.

(b) **Timing of forfeitures.** A Participant who receives an Involuntary Cash-Out Distribution (as described in AA §9-4(a)) is treated as having an immediate forfeiture of such Participant's nonvested Account Balance.

To modify the forfeiture timing rules to delay the occurrence of a forfeiture upon an Involuntary Cash-Out Distribution, complete this AA §8-7(b).

                     A forfeiture will occur at the end of the \_\_\_\_ year following the Involuntary Cash-Out Distribution.

**8-8 SPECIAL VESTING RULES.**

**ER    Match**

       Describe special vesting provisions: \_\_\_\_\_

**SECTION 9  
DISTRIBUTION PROVISIONS**

**9-1 AVAILABLE FORMS OF DISTRIBUTION.**

**Lump sum distribution.** Unless selected otherwise under subsection (e) below, a Participant may take a distribution of such Participant's entire vested Account Balance in a single lump sum.

**Additional distribution options.** To provide for additional distribution options, check the applicable distribution forms under this AA §9-1. If a lump sum distribution will not be provided under the Plan, check (e) below and indicate that no lump sum distribution is available under the Plan.

(a) **Partial lump sum.** A Participant may take a distribution of less than the entire vested Account Balance upon Severance from Employment.

**Minimum partial lump sum amount.** A Participant may not take a partial lump sum distribution of less than \$\_\_\_\_.

(b) **Installment distributions.** A Participant may take a distribution over a specified period not to exceed the life or life expectancy of the Participant (and a designated beneficiary).

(c) **Installment distribution for required minimum distributions.** A Participant may take an installment distribution solely to the extent necessary to satisfy the required minimum distribution rules under Section 9 of the BPD.

(d) **Annuity distributions.** A Participant may elect to have the Plan Administrator use the Participant's vested Account Balance to purchase an annuity.

(e) **Describe:** Repetitive Payments

*[Note: Any additional distribution option described in (e) will apply uniformly to all Participants under the Plan and may not be subject to the discretion of the Employer or Plan Administrator.]*

**9-2 PERMISSIBLE DISTRIBUTION EVENTS.**

(a) **Distribution events.** A Participant may withdraw all or any portion of such Participant's vested Account Balance, to the extent designated, upon the occurrence of the event(s) selected under this AA §9-2.

**Deferral                      Match                      ER**

                                                                 (1) No in-service distributions are permitted.

                                                                 (2) The attainment of age 59 1/2 (no earlier than age 59½).

Deferral	Match	ER	
<input checked="" type="checkbox"/>	<input type="checkbox"/>	<input type="checkbox"/>	(3) The occurrence of an Unforeseeable Emergency, as described in Section 8.08 of the BPD. <input type="checkbox"/> Participants who receive a distribution on the occurrence of an Unforeseeable Emergency may not make Salary Deferrals to the Plan for a period of 6 months.
<input checked="" type="checkbox"/>	<input type="checkbox"/>	<input type="checkbox"/>	(4) A Qualified Birth or Adoption Distribution, as described in Section 8.14 of the BPD.
<input type="checkbox"/>	<input type="checkbox"/>	<input type="checkbox"/>	(5) Upon a deemed Severance from Employment when an individual is on active duty for a period of at least 30 days while performing service in the Uniformed Services, as described under Section 15.05(c) of the BPD.
<input type="checkbox"/>	<input type="checkbox"/>	<input type="checkbox"/>	(6) An Emergency Personal Expense Distribution, as described in BPD Section 8.18.
<input type="checkbox"/>	<input type="checkbox"/>	<input type="checkbox"/>	(7) A Domestic Abuse Distribution, as described in BPD Section 8.19.
<input type="checkbox"/>	<input type="checkbox"/>	<input type="checkbox"/>	(8) A Qualified Disaster Recovery Distribution, as described in Section 8.17 of the BPD.
<input type="checkbox"/>	<input type="checkbox"/>	<input type="checkbox"/>	(9) A Qualified Long-Term Care Distribution, as described in Section 8.20 of the BPD. <i>[Note: Qualified Long-Term Care Distributions are not available under the Plan until after December 29, 2025.]</i>

(b) **Rollover Contributions.** Unless designated otherwise under this subsection (b), a Participant may withdraw amounts attributable to Rollover Contributions at any time. If this subsection (b) is selected, amounts attributable to Rollover Contributions may be distributed only upon the occurrence of the following event(s):

- (1) No in-service distributions are permitted.
- (2) The attainment of age \_\_\_\_.
- (3) The occurrence of an Unforeseeable Emergency, as described in Section 8.08 of the BPD.
- (4) The Participant qualifies for a Qualified Birth or Adoption Distribution, as described in Section 8.14 of the BPD.
- (5) Upon a deemed Severance from Employment when an individual is on active duty for a period of at least 30 days while performing service in the Uniformed Services, as described under Section 15.05(c) of the BPD.
- (6) Describe: \_\_\_\_\_

(c) **Distribution of Smaller Amounts.**

- (1) The Employer has discretion to make distribution of smaller amounts as described in Section 8.06 of the BPD.
- (2) The Participant may withdraw a distribution of smaller amounts as described in Section 8.06 of the BPD.
- (3) Special rules applicable to the distribution of smaller amounts: \_\_\_\_\_

(d) **Describe any special distribution rules applicable to a Participant's Transfer Account:** \_\_\_\_\_

**9-3 SPECIAL RULES FOR IN-SERVICE DISTRIBUTIONS.**

- (a) In-service distributions will only be permitted if the Participant is 100% vested in the amounts being withdrawn.
- (b) A Participant may take no more than \_\_\_\_ in-service distribution(s) in a Plan Year.
- (c) A Participant may not take an in-service distribution of less than \$\_\_\_\_.
- (d) A Participant may not take a distribution after Severance from Employment for the following in-service distributions elected under AA §9-2.
  - (1) Unforeseeable Emergency Distributions.
  - (2) Qualified Birth or Adoption Distributions.
  - (3) Emergency Personal Expense Distributions.
  - (4) Domestic Abuse Distributions.
  - (5) Qualified Long-Term Care Distributions.
- (e) Describe any special in-service distribution rules: \_\_\_\_\_

9-4 PARTICIPANT AND SPOUSAL CONSENT.

- (a) **Involuntary Cash-Out Distribution.** A Participant who has a Severance from Employment with a vested Account Balance of \$5,000 (or \$7,000, effective for distributions made after December 31, 2023) or less will receive an Involuntary Cash-Out Distribution in the form of a lump sum distribution, unless elected otherwise under this AA §9-4. If a Participant's vested Account Balance exceeds \$5,000 (or \$7,000, effective for distributions made after December 31, 2023), the Participant generally must consent to a distribution from the Plan, except to the extent provided otherwise under this AA §9-4.
- (1) **No Involuntary Cash-Out Distributions.** The Plan does not provide for Involuntary Cash-Out Distributions. A Participant who has a Severance from Employment must consent to any distribution from the Plan. (See Section 14.02(a) of the BPD for special rules upon Plan termination.)
- (2) **Involuntary Cash-Out Distribution threshold.** Instead of a vested Account Balance Involuntary Cash-Out Distribution threshold of \$5,000 (or \$7,000, effective for distributions made after December 31, 2023), a Participant who has a Severance from Employment will receive an Involuntary Cash-Out Distribution:
- (i) If the Participant's vested Account Balance is less than or equal to \$\_\_\_\_\_.
- (ii) Regardless of the value of the Participant's vested Account Balance (i.e., a Participant who has a Severance from Employment always will receive an Involuntary Cash-Out Distribution and no Participant consent is required).
- (3) **Application of Automatic Rollover rules.**
- (i) The Automatic Rollover rules described in Section 8.09(f) of the BPD do not apply to any Involuntary Cash-Out Distribution below \$1,000, unless elected otherwise under this subsection (i). If this subsection (i) is checked, the Automatic Rollover provisions apply to all Involuntary Cash-Out Distributions (including those below \$1,000).
- (ii) The Automatic Rollover rules only apply to Involuntary Cash-Out Distributions of Participants who have not attained Normal Retirement Age or age 62, if later.
- (4) **Distribution upon attainment of stated age.** Participant consent will not be required with respect to distributions made upon attainment of Normal Retirement Age (or age 62, if later), regardless of the value of the Participant's vested Account Balance.
- (5) **Treatment of Rollover Contributions.** In determining whether a Participant's vested Account Balance exceeds the Involuntary Cash-Out threshold for purposes of applying the distribution rules under this AA §9-4 and the Automatic Rollover provisions under Section 8.09(f) of the BPD, Rollover Contributions will be:
- (i) excluded.
- (ii) included.
- (b) **Spousal consent.** Spousal consent is not required for a Participant to receive a distribution or name an alternate Beneficiary, unless designated otherwise under this subsection (b).
- (1) **Distribution consent.** A Participant's spouse must consent to any distribution or loan, provided the Participant's vested Account Balance exceeds \$\_\_\_\_\_.
- (2) **Consent to Beneficiary.** A Participant's spouse must consent to naming someone other than the spouse as Beneficiary under the Plan.
- (3) **Spousal consent rights determined under administrative policy.** The Employer will establish spousal consent rights for the Plan under a separate administrative policy.
- (c) **Describe** any special rules relating to Participant or spousal consent: \_\_\_\_\_

9-5 **TIMING OF DISTRIBUTIONS.** The Plan Administrator will make distributions to a Participant (or Beneficiary) as soon as administratively feasible after the occurrence of an event, such as Severance from Employment, that allows a Participant or Beneficiary to receive a distribution. The Plan may condition the receipt of a distribution on Participant and/or spousal consent, as specified under AA §9-4.

9-6 DETERMINATION OF BENEFICIARY.

- (a) **Default beneficiaries.** Under Section 8.05(c) of the BPD, to the extent a Beneficiary has not been named by the Participant (subject to the spousal consent rules) to receive all or any portion of the deceased Participant's death benefit, such amount shall be distributed to the Participant's surviving spouse (if the Participant was married at the time of death) who shall be considered the designated Beneficiary. If the Participant does not have a surviving spouse at the time of death, distribution will be made to the Participant's surviving children (including legally adopted children, but not including step-children), as designated Beneficiaries, in equal shares. If the Participant has no surviving children, distribution will be made to the Participant's estate.
- If this subsection (a) is checked, the default beneficiaries under Section 8.05(c) of the BPD are modified as follows:

- (1) The Plan adopts the default beneficiary rules under Section 8.05(c) of the BPD, except, if the Participant does not have a surviving spouse at the time of death, distribution will be made to the Participant's children (including legally adopted children, but not including step-children), as designated Beneficiaries, **per stirpes**.
- (2) The Plan adopts the default beneficiary rules under Section 8.05(c) of the BPD, except, if the Participant does not have a surviving spouse at the time of death, distribution will be made to the Participant's estate.
- (3) The Plan adopts the default beneficiary rules under Section 8.05(c) of the BPD, except, if the Participant does not have a surviving spouse at the time of death, distribution will be made in the following order of priority: (1) to the Participant's children (including legally adopted children, but not including step-children), as designated Beneficiaries, **per stirpes**; (2) if there are no children, then to the Participant's surviving parents; and (3) if there are no surviving parents, to the Participant's estate.
- (4) Describe other modifications to the default beneficiaries under Section 8.05(c) of the BPD: To the extent a Beneficiary has not been named by the Participant to receive all of any portion of the deceased Participants death benefit, such amount shall be distributed to the Participants surviving Spouse. If the Participant does not have a surviving Spouse, distribution will be made to the Participants surviving children (including legally adopted children, but not including step-children) in equal shares by right of representation (one share for each surviving child and one share for each child who predeceases the Participant with living descendants). If the Participant has no surviving children, distribution will be made to the Participants surviving parents in equal shares. If the Participant has no surviving parents, distribution will be made to the Participants estate.

*[Note: The description of the modifications to the default beneficiaries must be sufficiently clear for the Plan Administrator to determine the beneficiaries and the method of distribution of the Participant's death benefit.]*

- (b) **One-year marriage rule.** For purposes of determining whether an individual is considered the surviving spouse of the Participant, the determination is based on the marital status as of the date of the Participant's death, unless designated otherwise under this subsection (b).

- If this subsection (b) is checked, in order to be considered the surviving spouse, the Participant and surviving spouse must have been married for the entire one-year period ending on the date of the Participant's death. If the Participant and surviving spouse are not married for at least one year as of the date of the Participant's death, the spouse will not be treated as the surviving spouse for purposes of applying the distribution provisions of the Plan.

- (c) **Divorce of spouse.** Unless elected otherwise under this subsection (c), if a Participant designates such Participant's spouse as Beneficiary and subsequent to such Beneficiary designation, the Participant and spouse are divorced, the designation of the spouse as Beneficiary under the Plan is automatically rescinded as set forth under Section 8.05 of the BPD.

- If this subsection (c) is checked, a Beneficiary designation will not be rescinded upon divorce of the Participant and spouse.

*[Note: Section 8.05 of the BPD and this subsection (c) will be subject to the provisions of a Beneficiary designation entered into by the Participant. Thus, if a Beneficiary designation specifically overrides the election under this subsection (c), the provisions of the Beneficiary designation will control. See Section 8.05 of the BPD.]*

#### 9-7 QUALIFIED DISTRIBUTIONS FOR RETIRED PUBLIC SAFETY OFFICERS.

Unless otherwise elected below, a Participant who is an eligible retired public safety officer may elect, after Severance from Employment, to have qualified health insurance premiums deducted from amounts to be distributed from the Plan that would otherwise be includible in gross income, and to have such amounts paid directly to the insurer or group health plan. (See Section 8.13 of the BPD.)

- If this subsection is checked, a Participant who is an eligible retired public safety officer may **NOT** elect to have qualified health insurance premiums deducted from amounts to be distributed from the Plan.

#### 9-8 REQUIRED MINIMUM DISTRIBUTIONS

- (a) **Required Beginning Date.** In applying the required minimum distribution rules under Section 9 of the BPD, the Required Beginning Date is the later of attainment of age 72 (age 70 ½ for Participants who attained age 70 ½ prior to January 1, 2020) or Severance from Employment. To override this default provision, check this subsection (a).

- The Required Beginning Date is the date the Employee attains age 72 (age 70 ½ for Participants who attained age 70 ½ prior to January 1, 2020), even if the Employee is still employed with the Employer.

- (b) **Temporary Waiver for 2020 - Default if Participant failed to elect.** For purposes of applying the required minimum distribution rules for the 2020 calendar year, effective January 1, 2020 (or such later date as designated below), a

Participant (including an Alternate Payee or beneficiary of a deceased Participant) who was eligible to receive a required minimum distribution for the 2020 calendar year could elect whether to receive the 2020 RMD or 2020 Extended RMD (as defined in Section 9.05(a) of the BPD). If a Participant did not specifically elect to take the 2020 RMD or 2020 Extended RMD from the Plan, such distribution was not made for the 2020 calendar year. The Employer may modify this default rule below, provided such modification satisfies the requirements under Code §401(a)(9)(I) and any applicable IRS guidance. (The temporary waiver for 2020 does not apply to Plans that are established after 2020 and no elections are required for such Plans.)

- (1) **2020 RMDs and 2020 Extended RMDs were made.** 2020 RMDs and 2020 Extended RMDs were made to Participants who were otherwise required to receive a required minimum distribution for the 2020 calendar year, unless the Participant elected to not receive such distribution.
- (2) **2020 RMDs were not made, but 2020 Extended RMDs were made.** 2020 RMDs were not made for the 2020 calendar year, but 2020 Extended RMDs were made for the 2020 calendar year, unless the Participant elected otherwise.
- (3) **2020 RMDs were made, but 2020 Extended RMDs were not made.** 2020 RMDs were made for the 2020 calendar year, but 2020 Extended RMDs were not made for the 2020 calendar year, unless the Participant elected otherwise.
- (4) **Direct Rollovers.** Unless elected otherwise below, the Plan offered a Direct Rollover only for distributions that were Eligible Rollover Distributions in the absence of Code §401(a)(9)(I).  
Instead of the default above, the following were treated as Eligible Rollover Distributions in 2020:
  - (i) 2020 RMDs
  - (ii) 2020 RMDs and 2020 Extended RMDs
  - (iii) 2020 RMDs, but only if paid with an additional amount that is an Eligible Rollover Distribution without regard to Code §401(a)(9)(I)
  - (iv) Describe: \_\_\_\_\_
- (5) **Describe other modifications of the default participant election rules:** \_\_\_\_\_
- (6) **Effective date.** Instead of January 1, 2020, the effective date of the amendment providing for a choice of whether a Participant or beneficiary could receive 2020 RMDs was effective: \_\_\_\_\_
- (7) **Describe any special rules, including any special effective dates, the Plan applied to RMDs for 2020:** \_\_\_\_\_

(c) **Required minimum distribution elections or rules.** Unless the Employer elects otherwise under this AA §9-8(c), RMDs under the Plan when the Participant dies prior to the Required Beginning Date shall be made as follows: (1) if the Participant does not have a Designated Beneficiary, distributions must satisfy the 5-year rule under Code §401(a)(9)(B)(ii); (2) if the participant has a Designated Beneficiary that is not an Eligible Designated Beneficiary, distributions must satisfy the 10-year rule; or (3) if the Participant has an Eligible Designated Beneficiary, distributions must satisfy the life expectancy rule. To override this default provision, complete (1) and/or (2) below.

- (1) **Application of life expectancy and 10-year rules to Eligible Designated Beneficiaries.** Instead of the default, the Plan will apply the following rule:
  - (i) The life expectancy rule applies to all Eligible Designated Beneficiaries.
  - (ii) The 10-year rule applies to all Eligible Designated Beneficiaries.
  - (iii) The entire interest of an Eligible Designated Beneficiary will be distributed by the end of the \_\_\_\_ calendar year [may not be greater than 9<sup>th</sup>] following the year the Participant dies.
  - (iv) The Participant or Eligible Designated Beneficiary may elect to apply either the 10-year rule or the life expectancy rule to determine the required minimum distributions when the Participant dies before such Participant's Required Beginning Date. If no election is timely made:
    - (A) the life expectancy rule applies to all Eligible Designated Beneficiaries.
    - (B) the 10-year rule applies to all Eligible Designated Beneficiaries.
    - (C) the 10-year rule, reduced to \_\_\_\_ years, applies to all Eligible Designated Beneficiaries.
  - (v) Describe the manner (including effective date) in which the 10-year rule and life expectancy rule apply to Eligible Designated Beneficiaries: \_\_\_\_\_
- (2) **Special rules.** Describe any special rules that apply for purposes of the required minimum distribution rules under Code §401(a)(9): \_\_\_\_\_

*[Note: Any special rules for determining required minimum distributions for calendar years beginning on or after January 1, 2022 (or such later date as specified in applicable regulations or guidance) must comply with proposed Treas. Reg §§1.401(a)(9)-1 through 1.401(a)(9)-9 issued on February 24, 2022 (or subsequent applicable final regulations).]*

9-9 SPECIAL DISTRIBUTION RULES.

Describe any additional distribution options or rules: \_\_\_\_\_

**SECTION 10**  
**MISCELLANEOUS PROVISIONS**

10-1 **PLAN VALUATION.** The Plan is valued **annually**, as of the last day of the Plan Year. In addition, the Plan will be valued on the following dates:

Deferral	Match	ER	
<input checked="" type="checkbox"/>	<input type="checkbox"/>	<input type="checkbox"/>	(a) <b>Daily.</b> The Plan is valued at the end of each business day during which the New York Stock Exchange is open.
<input type="checkbox"/>	<input type="checkbox"/>	<input type="checkbox"/>	(b) <b>Monthly.</b> The Plan is valued at the end of each month of the Plan Year.
<input type="checkbox"/>	<input type="checkbox"/>	<input type="checkbox"/>	(c) <b>Quarterly.</b> The Plan is valued at the end of each Plan Year quarter.
<input type="checkbox"/>	<input type="checkbox"/>	<input type="checkbox"/>	(d) <b>Describe:</b> _____

*[Note: The Employer may elect operationally to perform interim valuations.]*

10-2 **SPECIAL RULES FOR DETERMINING AMOUNT OF INCOME OR LOSS.** The following special rules apply in determining the amount of income or loss allocated to Participants' Accounts: \_\_\_\_\_

10-3 **MILITARY SERVICE PROVISIONS -- BENEFIT ACCRUALS.** The benefit accrual provisions under Section 15.05(b) of the BPD do not apply. To apply the benefit accrual provisions under Section 15.05(b) of the BPD, check the box below.

- (a) **Eligibility for Plan benefits.** Check this box if the Plan will provide the benefits described in Section 15.05(b) of the BPD. If this box is checked, an individual who dies or becomes disabled in qualified military service will be treated as reemployed for purposes of determining entitlement to benefits under the Plan.
- (b) **Describe special rules applicable to military service:** \_\_\_\_\_

10-4 **AUTOMATIC PORTABILITY TRANSACTIONS.** If elected below or as set forth in separate administrative procedures, the Employer may elect to accept amounts pursuant to an automatic portability transaction as described in Code §4975(f)(12) and BPD Section 4.03.

- (a) **Plan will accept automatic portability transactions.** Check this box if the Plan will accept amounts pursuant to an automatic portability transaction as described in Code §4975(f)(12) and BPD Section 4.03.
- (b) **Describe special rules applicable automatic portability transactions:** \_\_\_\_\_

10-5 **GOVERNING LAW.** Unless designated otherwise below, the provisions of this Plan shall be construed, administered, and enforced in accordance with the provisions of applicable Federal Law and, to the extent applicable, the laws of the state in which the Employer has its principal place of business.

- The provisions of the Plan shall be construed, administered, and enforced in accordance with the provisions of applicable Federal Law and, to the extent applicable, the laws of the state of \_\_\_\_\_.

10-6 **OTHER SPECIAL RULES APPLICABLE TO THIS PLAN.** The following special rules, including the applicability of any vendor agreements, apply to this Plan: \_\_\_\_\_

**APPENDIX A  
SPECIAL EFFECTIVE DATES**

- A-1 **Eligible Employees.** The definition of Eligible Employee under AA §3 is effective as follows:  
\_\_\_\_\_
- A-2 **Minimum age and service conditions.** The minimum age and service conditions and Entry Date provisions specified in AA §4 are effective as follows:  
\_\_\_\_\_
- A-3 **Compensation definitions.** The compensation definitions under AA §5 are effective as follows:  
\_\_\_\_\_
- A-4 **Employer Contributions.** The Employer Contribution provisions under AA §6 are effective as follows:  
\_\_\_\_\_
- A-5 **Salary Deferrals.** The Salary Deferral provisions under AA §6A are effective as follows:  
\_\_\_\_\_
- A-6 **Matching Contributions.** The Matching Contribution provisions under AA §6B are effective as follows:  
\_\_\_\_\_
- A-7 **Retirement ages.** The retirement age provisions under AA §7 are effective as follows:  
\_\_\_\_\_
- A-8 **Vesting and forfeiture rules.** The rules regarding vesting and forfeitures under AA §8 are effective as follows:  
\_\_\_\_\_
- A-9 **Distribution provisions.** The distribution provisions under AA §9 are effective as follows:  
\_\_\_\_\_
- A-10 **Miscellaneous provisions.** The provisions under AA §10 are effective as follows:  
\_\_\_\_\_
- A-11 **Special effective date provisions for merged plans.** If any Code §457(b) plan has been merged into this Plan, the following provisions apply:  
\_\_\_\_\_
- A-12 **Other special effective dates:**  
\_\_\_\_\_

**APPENDIX B  
LOAN POLICY**

Use this Appendix B to identify elections dealing with the administration of Participant loans. These elections may be changed without amending this Agreement by substituting an updated Appendix B with new elections.

B-1 Are **PARTICIPANT LOANS** permitted? (See Section 13 of the BPD.)

- (a) Yes  
 (b) No

B-2 **LOAN PROCEDURES.**

- (a) Loans will be provided under the default loan procedures set forth in Section 13 of the BPD, unless modified under this Appendix B.  
 (b) Loans will be provided under a separate written loan policy.  
*[Note: If this subsection (b) is checked, do not complete the rest of this Appendix B.]*

B-3 **AVAILABILITY OF LOANS.** Participant loans are available to all Participants and Beneficiaries. Participant loans are not available to a former Employee or Beneficiary. To override this default provision, complete this AA §B-3.

- A former Employee or Beneficiary who has a vested Account Balance may request a loan from the Plan.

B-4 **LOAN LIMITS.** The default loan policy under Section 13.03 of the BPD allows Participants to take a loan provided all outstanding loans do not exceed 50% of the Participant's vested Account Balance. To override the default loan policy to allow loans up to \$10,000, even if greater than 50% of the Participant's vested Account Balance, check this AA §B-4.

- A Participant may take a loan equal to the greater of \$10,000 or 50% of the Participant's vested Account Balance.  
*[Note: If this AA §B-4 is checked, the Participant may be required to provide adequate security as required under Section 13.06 of the BPD.]*

B-5 **NUMBER OF LOANS.** The default loan policy under Section 13.04 of the BPD restricts Participants to one loan outstanding at any time. To override the default loan policy and permit Participants to have more than one loan outstanding at any time, complete (a) or (b) below.

- (a) A Participant may have \_\_\_ loans outstanding at any time.  
 (b) There are no restrictions on the number of loans a Participant may have outstanding at any time.

B-6 **LOAN AMOUNT.** The default loan policy under Section 13.04 of the BPD provides that a Participant may not receive a loan of less than \$1,000. To modify the minimum loan amount or to add a maximum loan amount, complete this AA §B-6.

- (a) There is no minimum loan amount.  
 (b) The minimum loan amount is \$ \_\_\_\_\_.  
 (c) The maximum loan amount is \$ \_\_\_\_\_.

B-7 **INTEREST RATE.** The default loan policy under Section 13.05 of the BPD provides for an interest rate commensurate with the interest rates charged by local commercial banks for similar loans. To override the default loan policy and provide a specific interest rate to be charged on Participant loans, complete this AA §B-7.

- (a) The prime interest rate  
 plus \_\_\_ percentage point(s).  
 (b) Describe: \_\_\_\_\_  
*[Note: Any interest rate described in this AA §B-7 must be reasonable and must apply uniformly to all Participants.]*

B-8 **PURPOSE OF LOAN.** The default loan policy under Section 13.02 of the BPD provides that a Participant may receive a Participant loan for any purpose. To modify the default loan policy to restrict the availability of Participant loans, complete this AA §B-8.

- A Participant may only receive a Participant loan under the following circumstances: \_\_\_\_\_

- B-9 **APPLICATION OF LOAN LIMITS.** If Participant loans are not available from all contribution sources, the limitations under Code §72(p) and the adequate security requirements of the Department of Labor regulations will be applied by taking into account the Participant's entire Account Balance. To override this provision, complete this AA §B-9.
- The loan limits and adequate security requirements will be applied by taking into account only those contribution Accounts which are available for Participant loans.
- B-10 **CURE PERIOD.** The Plan provides that a Participant incurs a loan default if a Participant does not repay a missed payment by the end of the calendar quarter following the calendar quarter in which the missed payment was due. To override this default provision to apply a shorter cure period, complete this AA §B-10.
- The cure period for determining when a Participant loan is treated as in default will be \_\_\_\_\_ days (cannot exceed 90) following the end of the month in which the loan payment is missed.
- B-11 **PERIODIC REPAYMENT – PRINCIPAL RESIDENCE.** If a Participant loan is for the purchase of a Participant's primary residence, the loan repayment period for the purchase of a principal residence may not exceed ten (10) years.
- (a) The Plan does not permit loan payments to exceed five (5) years, even for the purchase of a principal residence.
- (b) The loan repayment period for the purchase of a principal residence may not exceed \_\_\_\_\_ years (may not exceed 30).
- (c) Loans for the purchase of a Participant's primary residence may be payable over any reasonable period commensurate with the period permitted by commercial lenders for similar loans.
- B-12 **SEVERANCE FROM EMPLOYMENT.** Section 13.10 of the BPD provides that a Participant loan becomes due and payable in full upon the Participant's Severance from Employment. To override this default provision, complete this AA §B-12.
- A Participant loan will not become due and payable in full upon the Participant's Severance from Employment.
- B-13 **DIRECT ROLLOVER OF A LOAN NOTE.** Section 13.10(b) of the BPD provides that upon Severance from Employment a Participant may request the Direct Rollover of a loan note. To override this default provision, complete this AA §B-13.
- A Participant may **not** request the Direct Rollover of the loan note upon Severance from Employment.
- B-14 **LOAN RENEGOTIATION.** The default loan policy provides that a Participant may renegotiate a loan, provided the renegotiated loan separately satisfies the reasonable interest rate requirement, the adequate security requirement, the periodic repayment requirement and the loan limitations under the Plan. The Employer may restrict the availability of renegotiations to prescribed purposes provided the ability to renegotiate a Participant loan is available on a non-discriminatory basis. To override the default loan policy and restrict the ability of a Participant to renegotiate a loan, complete this AA §B-14.
- (a) A Participant may **not** renegotiate the terms of a loan.
- (b) The following special provisions apply with respect to renegotiated loans: \_\_\_\_\_
- B-15 **SOURCE OF LOAN.** Participant loans may be made from all available contribution sources, to the extent vested, unless designated otherwise under this AA §B-15.
- Participant loans will not be available from the following contribution sources: \_\_\_\_\_
- B-16 **SPOUSAL CONSENT.** Spousal consent is not required for a Participant to receive a loan. To override this provision, complete this AA §B-16.
- Spousal consent is required to receive a Participant loan.
- B-17 **MODIFICATIONS TO DEFAULT LOAN PROVISIONS.**
- The following special rules will apply with respect to Participant loans under the Plan: \_\_\_\_\_
- [Note: Any provision under this AA §B-17 must satisfy the requirements under Code §72(p) and the regulations thereunder and will control over any inconsistent provisions of the Plan dealing with the administration of Participant loans.]*

**APPENDIX C  
ADMINISTRATIVE ELECTIONS**

Use this Appendix C to identify certain elections dealing with the administration of the Plan. These elections may be changed without re-executing this Agreement by substituting an updated Appendix C with new elections.

**C-1 DIRECTION OF INVESTMENTS.** Are Participants permitted to direct investments?

- (a) No  
 (b) Yes

Specify Accounts:

- (1) All Accounts  
 (2) Pre-Tax Salary Deferral Account  
 (3) Roth Deferral Account  
 (4) Matching Contribution Account  
 (5) Employer Contribution Account  
 (6) Rollover Contributions Account  
 (7) Transfer Account  
 (8) Other: \_\_\_\_\_
- (c) Describe any special rules that apply for purposes of direction of investments: \_\_\_\_\_

**C-2 ROLLOVER CONTRIBUTIONS.** Does the Plan accept Rollover Contributions?

- (a) No  
 (b) Yes

- (1) If this subsection (1) is checked, an Employee may make a Rollover Contribution to the Plan prior to becoming a Participant in the Plan.  
 (2) Check this subsection (2) if the Plan will accept Rollover Contributions from former Employees with an Account Balance under the Plan.  
 (3) Describe any special rules for accepting Rollover Contributions: From any Eligible Retirement Plan eligible to be rolled into this Plan excluding After-Tax contributions

*[Note: The Employer may designate in this subsection (3), or in separate written procedures, the extent to which it will accept rollovers from designated plan types. For example, the Employer may decide not to accept rollovers from certain designated plans (e.g., 403(b) plans, §457 plans or IRAs). Any special rollover procedures will apply uniformly to all Participants under the Plan.]*

**C-3 QDRO PROCEDURES.** Do the default QDRO procedures under Section 11.06 of the BPD apply?

- (a) No  
 (b) Yes

**EMPLOYER SIGNATURE PAGE**

**PURPOSE OF EXECUTION.** This Signature Page is being executed to effect:

- (a) The adoption of a **new plan**, effective \_\_\_\_\_ [Date can be no earlier than the first day of the Plan Year in which the Plan is adopted].
- (b) The **restatement** of an existing plan, effective February 11, 2026 [Date can generally be no earlier than the first day of the Plan Year in which the Plan is adopted].
- (1) Name of Plan(s) being restated: County of Tazewell 457(b) Deferred Compensation Plan
- (2) The original effective date of the plan(s) being restated: June 8, 1993
- (c) An **amendment** of the Plan. If this Plan is being amended, the updated pages of the Adoption Agreement may be substituted for the original pages in the Adoption Agreement. All prior Employer Signature Pages should be retained as part of this Adoption Agreement.
- (1) Effective Date(s) of amendment: \_ [Date can generally be no earlier than the first day of the Plan Year in which the Plan is adopted]
- (2) Name of plan being amended: \_\_\_\_\_
- (3) The original effective date of the plan(s) being amended: \_\_\_\_\_
- (4) Identify the section(s) of the Adoption Agreement being amended: \_\_\_\_\_

County of Tazewell, IL  
(Name of Employer)

\_\_\_\_\_  
(Name of authorized representative) (Title)

\_\_\_\_\_  
(Signature) (Date)

Employers should consult with legal counsel to ensure that the Plan meets applicable federal, State and local law requirements.

The IRS does not maintain a pre-approved plan program or a determination letter program for Code §457(b) plans. Employers who want the Internal Revenue Service to review their Code §457(b) plan document or consider any other document form issue may request a private letter ruling. See Revenue Procedure 2023-1 (or annual successor Revenue Procedure) for details.

**TRUST DECLARATION**

Effective date of Trust Declaration: November 4, 2025

**The Trustee's Investment Powers are:**

- (a) **Discretionary.** A Trustee is a Discretionary Trustee to the extent the Trustee has exclusive authority and discretion with respect to the investment, management or control of Plan assets.
- (b) **Nondiscretionary.** A Trustee is a Directed Trustee with respect to the investment of Plan assets to the extent the Trustee is subject to the direction of the Plan Administrator or the Employer.
- (c) **No Trustee.** Plan is funded exclusively with custodial accounts, annuity contracts, and/or insurance contracts. (See Section 12.12 of the BPD.)
- (d) **Determined under a separate trust agreement.**

Name of Trustee: Nationwide Trust Company, FSB

Title of Trust Agreement: Nationwide Trust Agreement

Address: 3 Nationwide Plaza

Columbus, Ohio 43215

Description of any special Trustee powers: \_\_\_\_\_

# Participant FAQ:

## Roth catch-up contribution changes



### What is the new Roth catch-up mandate?

Beginning in 2026, if you meet the following criteria, you must make age-based catch-up contributions as Roth (after-tax) contributions:

- Are age 50 or older
- Plan to make age 50 catch-up contributions
- Earned more than \$145,000 in W-2 FICA wages<sup>1</sup> in 2025 from this employer

### What are Roth catch-up contributions?

Roth catch-up contributions are after-tax contributions made to your retirement plan once you reach the age of 50 or older. These contributions allow you to save more than the standard annual limit, helping you boost your retirement savings as you approach retirement.

Unlike traditional pretax contributions, you pay the taxes upfront.

Your qualified withdrawals in retirement are tax-free, including earnings provided:

- You've held the account for at least 5 years
- You're at least 59½ years old
- View this year's IRS contribution limits at [nrsforu.com/rsc-preauth/investing/irs-limits](https://nrsforu.com/rsc-preauth/investing/irs-limits)



### What happens if I don't update my deferral elections?

If your plan supports Roth contributions, your catch-up contributions may be automatically treated as Roth, even if you originally elected pretax. This is called a "deemed Roth election."

- These contributions and earnings will be reported as taxable income, and you'll receive a Form 1099-R.
- If your plan does not support Roth contributions, you won't be able to make catch-up contributions at all.

**Important:** If you mistakenly make pretax catch-up contributions and a Roth correction is required later, all associated earnings will be subject to taxation. However, if you elect Roth contributions during the calendar year, your earnings can grow tax-free, provided you meet the qualified distribution requirements.

### How do I calculate the correct percentage for my catch-up deferral?

Use this formula:

- Deferral catch-up % = (annual catch-up goal ÷ annual compensation) × 100

Example: If you earn \$150,000 and want to contribute the full catch-up amount of \$7,500:

- Deferral % = (7,500 ÷ 150,000) × 100 = 5%
- You would set your Roth catch-up deferral to 5% of your pay

### Does it matter when I make Roth contributions during the year?

No, the timing of your Roth catch-up contributions within the year does not matter. As long as your contributions exceed the standard 402(g) elective deferral limit and you meet the eligibility criteria (age 50+ and prior-year wages over \$145,000), those contributions will count toward satisfying the Roth catch-up mandate.

402(g) limit (\$23,500 for 2025)		Mandatory Roth Catch-Up Up to \$7,500 for age 50+ and \$11,250 for 60-63 (e.g., earned over \$145,000 in FICA wages in prior year)
Pretax contributions	Roth contributions	Roth contributions
Total employee deferrals for the year		

All Roth contributions count toward the Roth catch-up requirement, regardless of when made

### Do I need to take action now?

Not immediately, but we recommend taking the following actions in January 2026:

- Review your current deferral elections
- Watch for future communications from HR or your plan provider
- Review Box 3 in your W-2 by the end of January 2026
- Prepare to make updates at the beginning of 2026

### Who can I contact with questions?

Please reach out to your HR representative or plan administrator for assistance.

<sup>1</sup> FICA wages are earnings subject to Social Security taxes, including salary, tips, bonuses, commissions and certain benefits. You can find this total in Box 3 of your W-2 form.



## Retirement Plans Education Series

# Benefits Bulletin

### FINAL REGULATIONS ON SECURE 2.0'S REQUIRED ROTH CATCH-UPS FOR HIGH EARNERS

---

#### I. A BRIEF HISTORY OF SECURE 2.0'S ROTH CATCH-UP REQUIREMENT

Section 603 of SECURE 2.0, which was signed into law at the end of 2022, mandates that catch-up contributions made by participants aged 50 or older with prior-year FICA wages exceeding \$150,000 (2026 limit for 2025 FICA wages) must be made on a Roth basis. This requirement applies to 401(k), 403(b), and governmental 457(b) plans. Initially, the statutory language indicated it was to be effective in 2024.

However, the IRS granted a two-year administrative transition period in IRS Notice 2023-62, delaying enforcement until January 1, 2026. In early 2025, the IRS issued Proposed Regulations on this section of SECURE 2.0, but certain administrative questions remained. Thankfully, the IRS issued much anticipated Final Regulations on the Roth catch-up requirement in mid-August of 2025 that addressed many of those outstanding questions. These Final Regulations provide much appreciated details that will allow retirement plan sponsors, administrators, recordkeepers, and other financial professionals to proceed with implementing this new rule. A summary of some of the most important information from those Final Regulations follows.

#### II. IDENTIFYING IMPACTED HIGH EARNERS

The Final Regulations confirmed that participants impacted by this requirement are those whose FICA wages from the "employer sponsoring the plan" in the preceding year were more than \$150,000 (i.e., "high earners"). The Final Regulations also clarified that the \$150,000 threshold is based on Box 3 of Form W-2 (Social Security wages), not Box 5 (Medicare wages). Some state and local governmental employees are exempt from Social Security (but not Medicare) and consequently, do not have Box 3 wages. This approach is consistent with the IRS' position in Notice 2023-62 and the Proposed Regulations, which said that the Roth catch-up requirement does not apply to public employees who are exempt from Social Security.

Although only wages from a participant's common law employer count toward the \$150,000 threshold, the Final Regulations permit, but do not require, a plan to aggregate wages from related employers using a common paymaster or within a controlled group, provided the plan document specifies this aggregation method.

#### III. DEEMED ROTH CATCH-UP ELECTIONS

The Proposed Regulations provided that a high earning plan participant subject to the mandatory Roth catch-up requirement may be deemed to have elected that any catch-up contributions will be made as Roth. For example, if a high earning participant elected only pre-tax contributions and exceeded the Code section 402(g) dollar limit (e.g., \$24,500 in 2026), any further elective contributions will be automatically made as Roth contributions. The Final Regulations provided some important clarifying changes with respect to these deemed Roth elections:

- For plans that provide for a single deferral election and provide for catch-up contributions only once the Code section 402(g) dollar limit is exceeded, the deemed Roth election will apply when the pre-tax contributions reach the limit, or when any combination of pre-tax and Roth contributions reach the limit.
- For plans that provide for separate elections for "regular" pre-402(g) limit deferrals and catch-up contributions, plans can deem the separate election for catch-up contributions to be an election to make Roth contributions. In the event that pre-402(g) limit deferral elections result in contributions below the Code section 402(g) limit, plans are not required to reverse the deemed election.

There are also a few other key points to note about deemed Roth catch-up elections. First of all, deemed Roth elections must cease within a reasonable period if it is discovered that the impacted participant no longer meets the high-earner criteria. Also, for plans that intend to incorporate deemed Roth catch-up elections, the plan documents must be amended to accurately describe how this feature will work.

## IV. CORRECTION METHODS

Both the Proposed and Final Regulations provide for two specific correction methods: a W-2 correction and an in-plan Roth rollover correction.

- Under the W-2 correction method, a high earning participant's Form W-2 may be adjusted to report improper pre-tax contributions as Roth contributions. This method is available only for impacted participants whose Form W-2s have not been filed or furnished. Practically speaking, many errors may not be discovered until several months after the end of the plan year, making this correction method of limited use.
- Under the in-plan Roth rollover correction method, an improper pre-tax contribution (as adjusted for earnings/losses) would be converted to a Roth contribution via a direct in-plan rollover. Like other in-plan Roth rollovers, the participant would receive a Form 1099-R for the year of the in-plan rollover.

There are also a number of key points to note about these two correction methods:

- If a plan is using deemed Roth catch-up elections (see Section III, above), both the W-2 and in-plan Roth rollover correction methods must be available.
- An employer is permitted to use both election methods in a given year, so long as the same method is used for similarly situated participants. This would allow employers to use the W-2 correction method for high earning participants who have not received their Form W-2 and the in-plan Roth rollover method for others.
- To use the in-plan Roth rollover method, a plan does not otherwise need to permit Roth rollovers.
- Corrections using these two methods must be made no later than the end of the tax year following the year of the improper contribution.
- The final regulations established a \$250 de minimis threshold, which means that wrongly reported pre-tax contributions below this amount do not need corrected.

## V. REGULATORY APPLICABILITY DATE AND AMENDMENT DEADLINE

While some hoped for an extension or modification of the administrative transition period provided by IRS Notice 2023-62, which provided a de facto extension of the original effective date of the Roth catch-up requirement specified in the statutory language of SECURE 2.0, the Final Regulations did not provide for this. Instead, they direct plan sponsors to proceed with implementing the Roth catch-up requirement using a "reasonable, good faith interpretation" in 2026. Compliance with the Final Regulations will then apply to taxable years beginning after December 31, 2026.

For most calendar year plans, amendments to implement the required Roth-catch-up provisions and other SECURE 2.0 changes must be adopted by December 31, 2026. However, special amendment deadlines apply for collectively bargained and governmental plans.

## VI. NEXT STEPS TOWARDS IMPLEMENTATION

Plan sponsors should begin working with their retirement plan partners (i.e., recordkeepers, third-party administrators, and/or payroll vendors) now to begin preparations to implement the Roth catch-up requirement in accordance with the guidance provided from the Final Regulations. As those preparations commence and proceed, please consider the following:

- Review payroll systems to make sure the correct high earners are identified, using Box 3 FICA wages.
- Coordinate with payroll and recordkeepers to ensure proper tracking and reporting, both for the plan and for individual participants' tax reporting.
- Evaluate whether to offer the super catch-up contributions for participants aged 60–63. This is a separate catch-up provision from SECURE 2.0 that allows participants in this age category a higher annual catch-up contribution limit (up to \$11,250 per year in 2026). Although this separate super catch-up contribution is optional, it must be consistently applied across all retirement plans in a controlled group.
- Review and amend plan documents to include Roth catch-up provisions and deemed election language (if appropriate) as well as all other required or optional changes to the plan from SECURE 2.0.
- Review and update plan communication materials (e.g., summary plan descriptions, summary of material modifications, any other required notices, and any other participant communications) to ensure participants are informed of these changes, especially those nearing age 50.



**Nationwide**<sup>®</sup>  
is on your side

This material is not a recommendation to buy or sell a financial product or to adopt an investment strategy. Investors should discuss their specific situation with their financial professional.

Federal income tax laws are complex and subject to change. The information in this memorandum is based on current interpretations of the law and is not guaranteed. Neither Nationwide, nor its employees, its agents, brokers or registered representatives give legal or tax advice. Nationwide, the Nationwide N and Eagle and Nationwide is on your side are service marks of Nationwide Mutual Insurance Company.

© 2025 Nationwide

NFM-25108AO.1 (11/25)

**COMMITTEE REPORT**

Mr. Chairman and Members of the Tazewell County Board:

Your Executive Committee has considered the following RESOLUTION and recommends that it be adopted by the Board:

---

**RESOLUTION**

WHEREAS, the County's Executive Committee recommends the County Board approve the attached Decommissioning Agreement for Hawk Solar, LLC; and

WHEREAS, the County Board approved the Special Use request for the 3.5 MW solar project July 31<sup>st</sup>, 2024, with conditions; and

WHEREAS, the solar site is approximately 25 acres of an 81-acre parcel located on Hilst Rd approximately 1/2 mile East of Wagonseller Rd., Green Valley, IL in Malone Township; and

WHEREAS, the agreement is in accordance with the Illinois Department of Agriculture's - Agricultural Impact Mitigation Agreement, in accordance with 20 ILCS 5/5-222 and Chapters 156 and 157 of the Tazewell County Code.

THEREFORE, BE IT RESOLVED that the County Board approves this recommendation

BET IT FURTHER RESOLVED that the County Clerk notifies the County Board Office, Community Development, and the Auditor of this action.

PASSED THIS 25<sup>th</sup> DAY of March 2026.

ATTEST:

  
\_\_\_\_\_  
TAZEWELL COUNTY CLERK  
CHAIRMAN

  
\_\_\_\_\_  
TAZEWELL COUNTY BOARD

**HAWK SOLAR  
DECOMMISSIONING PLAN  
February 2026**

**Purpose**

This decommissioning plan is provided by Hawk Solar, LLC (the “Project Company”) and will detail the projected decommissioning demands associated with the proposed project.

The purpose of this decommissioning plan is to provide procedures and an opinion of probable construction cost for partial or full closure of the solar facility. Tazewell County Zoning Code requires a decommissioning plan and performance guarantees to supplement plans submitted as part of a SUP package. This decommissioning plan details provisions for facility deconstruction and site restoration, to satisfy the specific guidelines set forth in the Project’s Special Use Permit. This decommissioning plan shall take effect upon facility abandonment, discontinuation of operation, or expiration of the use permit as defined by the Tazewell County Zoning Code.

**Site Location**

Hawk Solar proposes to build a photovoltaic (PV) solar facility (“Solar Facility”) with a nameplate capacity of approximately 3.5 MW<sub>AC</sub> (“Project”), in Tazewell County, IL. The Facility is located at 13127 Hilst Road, Green Valley, IL 61534 and within tax parcel identification numbers 20-20-05-200-003 (“Property”).

**Anticipated Service Life of the Project**

The facility shall be decommissioned in accordance with this Decommissioning Plan (“Plan”), restoring the site to as close to its agreed-upon post-decommissioned state as practicably possible upon expiration or termination of the Power Purchase Agreement or within twelve (12) months after the end of the useful life of the facility. The expected useful life of the Project is forty (40) years and is expected to be operational for the full forty (40) years.

Decommissioning responsibilities include the removal of any perimeter fences, any concrete pads, all metal structures (mounting racks and trackers), all photovoltaic (PV) modules, pipelines, alternators, generators, aboveground and underground cables, transformers, inverters, fans, switch boxes, fixtures, etc. and otherwise restoring the premises to its original position or mutually-agreed upon state. Other Plan activities include the management of materials and waste, projected costs, and a decommissioning fund agreement overview.

## Decommissioning Risk Over the Lifecycle of a Project

The probability of an event that would lead to abandonment or long-term interruption is extremely low during the first 15 to 20 years of the Project life. Accordingly, the risk of decommissioning the Project is extremely low during this time frame. The reasons why the risk to decommission the Project is extremely low in the early phases of the Project include, but are not limited to:

- Project owners have sophisticated financing structures that allow the lender or tax equity partner to step in and rectify the event that may lead to abandonment.
- Most critical solar components have original equipment manufacturer (OEM) warranties with terms exceeding five years that include labor and parts. A warranty is an agreement or guarantee outlined by a manufacturer to a customer that defines performance requirements for a product or service. Warranties give customers a form of insurance if the purchased product or service does not adhere to quality standards. These warranties assure the Project owner, financing parties, and other stakeholders, that equipment will perform as expected which minimizes the risk of a decommissioning event. Average warranty lengths for critical solar components range from 5 to 10 years, with production warranties on solar panels extending to 20 to 25 years.
- Solar projects consist of many networked components designed to convert solar radiation into electrical energy. The failure of any single component will not result in a substantial reduction of energy generation that could lead to a decommissioning event.
- Solar projects are required to maintain replacement value property damage insurance coverage and business interruption insurance coverage. Business interruption insurance covers the loss of income that a business suffers after a disaster or equipment failure. Typical solar business interruption insurance covers income loss for twelve months from the date of the event triggering the loss.
- The replacement costs of solar components will typically decline over time, and accordingly, costs to replace failed or damaged equipment after lapsed OEM warranties will not create large financial hurdles for the Project.
- In the early stages of the Project, the resale value of the equipment is significantly higher than the decommissioning costs, resulting in a net positive (revenue).

Considering the reasons stated above, a decommissioning bond early in the life of a solar project life is not required to assure the coverage facility removal and site restoration costs. However, it is noted that the Tazewell County Zoning Code requires Financial Assurance be provided to the County.

Solar power is an increasingly popular form of renewable energy around the world and as an alternative to the burning of fossil fuels, solar ranks alongside wind and hydropower as essential energy options for the future of the planet. Solar also offers the additional benefit of being easier to build, operate, and decommission with minimal environmental risks. Recent rises in popularity and use can be linked to lower installation and operation costs and it is expected that this pattern will continue, further reducing the risk of a decommissioning event.

## **Removal of Nonutility Owned Equipment**

To decommission the Solar Facility, the Project will include at a minimum:

- Disconnection from the utility power grid
- Removal of all Facility components: panels, inverters, wire, cable, combiner boxes, transformers, racks, trackers, tracker motors, weather monitoring, control system apparatus, etc.
- Removal of all non-utility owned equipment (at point of interconnection), conduits, structures, fencing, and foundations to a depth of at least five feet below grade.
- Restoration of property to a condition reasonably similar to its condition prior to Facility installation, or as initially agreed upon.
- Plant vegetation suitable for the location, native to the region, and which matches surrounding vegetation.

The owner of the leased property may request in writing for certain items to remain, e.g., access roads.

This decommissioning plan is based on current best management practices and procedures. This Plan may be subject to revision based on new standards and emergent best management practices at the time of decommissioning. Permits will be obtained as required and notification will be given to necessary stakeholders prior to decommissioning.

The decommissioning process will maximize the recycling, reuse and salvage of applicable facility components, which are outlined in the opinion of probable construction costs. Decommissioning activities will not begin prior to issuance of approved permits by local regulatory agencies with appropriate jurisdiction.

## **Restoration of Property**

At the time of decommissioning, the Project Company will restore the Solar Facility to a meadow-like condition. All waste, debris, and excess materials will be disposed of in accordance with municipal, provincial, and federal regulations. Waste that can be recycled under municipal programs will be recycled accordingly. Provided, however, the Project Company shall not be required to replace any structures that were removed to build the Solar Facility.

Mass grading is not anticipated since the initial project will not alter topography significantly. At the end of the project the area will be seeded and fertilized with native vegetation as needed to return the site to as close as practicable to original or initially agreed-upon condition. Per a drain tile investigation performed by ANS Geo, drain tile on site is highly unlikely. If drain tile is found on site and damaged during decommissioning of the solar energy facility, the Project Company shall promptly repair existing drainage tiles or install new drainage tile lines of comparable quality and cost to the original. The Landowner must agree to the restoration method used for any Subsurface Drainage repairs. The Project Company shall be responsible for correcting any drain tile line repairs that failed due to deconstruction for one year following the completion of the deconstruction. Additional detail can be found in the "Rerouting and Permanent Repair of Agricultural Drainage Tiles"

section of the Standard AIMA Agreement between Hawk Solar, LLC and the Illinois Department of Agriculture.

### **Time Period to Complete Decommissioning**

The Project Company will have twelve (12) months from the date decommissioning commences to complete decommissioning. Provided, however, the Project Company shall be able to request an extension if it is in good faith diligently decommissioning and is delayed due to weather conditions or other items outside its control.

### **Financial Assurance**

Tazewell County Zoning Code requires Hawk Solar, LLC to provide a faithful performance bond as a financial guarantee for proper decommissioning. This bond is separate from, and in addition to, performance bonding submitted for permitting. Financial Assurance shall be phased over the first 11 years of the Project's operation as follows:

1. Within the first year of the Commercial Operation Date, the Facility Owner shall provide 10% of the probable cost of decommissioning to the County.
2. Within the first six years of the Commercial Operation Date, the Facility Owner shall provide 50% of the probable cost of decommissioning to the County.
3. Within the first 11 years of the Commercial Operation Date, the Facility Owner shall provide 100% of the probable cost of decommissioning to the County.

See the associated costs with the bonding schedule in the section below. The County may, but is not required to, reevaluate the estimated costs of Decommissioning of the Facility after the tenth anniversary of the Commercial Operation Date and every five years afterwards. Additional detail can be found in Title XV, Chapter 156.06, Section (B)(18) in the Tazewell County Zoning Code.

### **Decommissioning Cost Estimate and Bonding**

An engineer's opinion of probable construction cost and analysis of material salvage value were prepared as part of this decommissioning plan. Exhibit A summarizes the probable costs associated with decommissioning including the deduction of salvage values.

Expenses associated with decommissioning the Project will be dependent on labor costs at the time of decommissioning. For the purposes of this report, current RSMeans data was used to estimate labor, material, and equipment expenses. Fluctuation and inflation of the labor costs were factored into the estimates.

Total probable cost of decommissioning in Year 40 (including salvage) is estimated to be **\$879,386**.

Bond Schedule:

1. **\$87,939** on or before the first anniversary of the Commercial Operation Date.
2. **\$439,693** on or before the sixth anniversary of the Commercial Operation Date.
3. **\$879,386** on or before the eleventh anniversary of the Commercial Operation Date.

**EXHIBIT A**

**Hawk Solar, LLC  
Tazewell County, IL  
Decommissioning Estimate Pro Forma w/ Salvage**

The Engineer has no control over the cost of labor, materials, equipment, or over the Contractor's methods of determining prices or over competitive bidding or market conditions. Opinions of probable costs provided herein are based on the information known to Engineer at this time and represent only the Engineer's judgment as a design professional familiar with the construction industry. The Engineer cannot and does not guarantee that proposals, bids, or actual construction costs will not vary from its opinions of probable costs. LS = Lump Sum, HR = Hours, EA = Each, LF = Linear Feet.

Item	Quantity	Unit	Unit Price	Total Salvage	Total Price (incl. markups)	Total Price
Mobilization	1	LS		\$ -	\$16,700.00	\$ (16,700.00)
Supervision	210	HR	\$109.00	\$ -	\$22,890.00	\$ (22,890.00)
Temporary Facilities	1	LS		\$ -	\$1,940.00	\$ (1,940.00)
Safety	1	LS		\$ -	\$1,310.00	\$ (1,310.00)
Legal Expenses	1	LS		\$ -	\$350.00	\$ (350.00)
General Liability Insurance	1	LS		\$ -	\$1,410.00	\$ (1,410.00)
Contractor's G&A	1	LS		\$ -	\$2,650.00	\$ (2,650.00)
SWPPP, Erosion Control Measures (Disturbed Area)	20	Ac	\$800.00	\$ -	\$16,000.00	\$ (16,000.00)
Seeding	1	Ac	\$4,087.64	\$ -	\$4,087.64	\$ (4,087.64)
Tilling 6" topsoil/scarifying access road and rough grading existing soil	1	Ac	\$33,563.63	\$ -	\$33,563.63	\$ (33,563.63)
Remove and Recycle Chainlink Fence	4,192	LF	\$6.67	\$ 3,670.82	\$27,960.64	\$ (24,289.82)
Remove Power Pole	5	EA	\$1,125.27	\$ -	\$5,626.35	\$ (5,626.35)
Remove and Recycle AC Cables	130	LF	\$44.48	\$ 27.24	\$5,782.22	\$ (5,754.99)
Remove and Recycle DC Cables	143,089	LF	\$0.58	\$ 29,977.23	\$82,797.82	\$ (52,820.59)
Backfill AC and DC trenches	77,039	LF	\$0.42	\$ -	\$32,734.31	\$ (32,734.31)
Remove and Recycle Inverters	2	EA	\$6,770.77	\$ 3,600.00	\$13,541.54	\$ (9,941.54)
Remove and Recycle Photovoltaic Modules	8,675	EA	\$6.23	\$ 27,193.20	\$54,045.25	\$ (26,852.05)
Remove and Recycle Piles	1,750	EA	\$8.71	\$ 30,648.52	\$15,242.50	\$ 15,406.02
Remove and Recycle Support Assemblies	270,066	LB	\$0.07	\$ 42,230.27	\$19,937.33	\$ 22,292.94
Contaminated Soils Testing	1	LS		\$ -	\$7,500.00	\$ (7,500.00)
Reclamation Monitoring and Maintenance	1	LS		\$ -	\$15,000.00	\$ (15,000.00)
<b>Subtotal:</b>				<b>\$ 137,347.27</b>	<b>\$381,069.23</b>	<b>\$ (243,721.95)</b>
					<b>Inflation (3.26%/year):</b>	<b>\$ (635,663.91)</b>
					<b>Total:</b>	<b>\$ (879,385.87)</b>

**Notes:**

- Labor productivity and unit rates were derived from RSMeans Online (Heavy Construction, 2025 data). The current Consumer Price Index was utilized to determine the inflation rate.
- Labor, material, and equipment rates are based on the RSMeans City Cost Index (CCI) for Peoria, IL.
- Material salvage values were based off of current US salvage exchange rates.
- Equipment rental rates determined from RSMeans and/or local rental facilities.
- Photovoltaic Module material salvage rate is based on straight-line depreciation of modules (-0.5% per year).
- For PV Module Removal/Recycle labor and equipment costs are computed at present values, while salvage value is computed at depreciated values.
- Material salvage values were determined using the most prevalent salvageable metal in each component. Copper Wire @ \$0.21/LF (AC and DC Cables) and Steel @ \$0.88/LF of fence, @ \$01.09/pile, and @ \$0.16/LB.
- Inverter resale value is dependent on the assumption that all inverters will be decommissioned and resold at the end of their useful life (every 10 years).
- Inflation has been calculated at 3.26%, the average inflation rate of CPI-U from the three prior calendar years.
- This estimate assumes 100 modules/tracker.
- This estimate assumes 77,162 LB of support assemblies per 1 MW output.
- This estimate assumes 500 piles/MW.

**COMMITTEE REPORT**

Mr. Chairman and Members of the Tazewell County Board:

Your Executive Committee has considered the following RESOLUTION and recommends that it be adopted by the Board:

---

**RESOLUTION**

WHEREAS, the County's Executive Committee recommends the County Board approve the attached Decommissioning Agreement for Coyote Road Solar, LLC; and

WHEREAS, the County Board approved the Special Use request for the 150 MW solar project June 26<sup>th</sup>, 2024, with conditions; and

WHEREAS, the solar site is approximately 1300 acres, including 15 separate parcels, situated in both Malone and Delavan Townships; and

WHEREAS, the agreement is in accordance with the Illinois Department of Agriculture's - Agricultural Impact Mitigation Agreement, in accordance with 20 ILCS 5/5-222 and Chapters 156 and 157 of the Tazewell County Code.

THEREFORE, BE IT RESOLVED that the County Board approves this recommendation

BET IT FURTHER RESOLVED that the County Clerk Notified the County Board Office, Community Development, and the Auditor of this action.

PASSED THIS 25<sup>th</sup> DAY of March 2026.

ATTEST:

  
\_\_\_\_\_  
TAZEWELL COUNTY CLERK

  
\_\_\_\_\_  
TAZEWELL COUNTY BOARD CHAIRMAN

**Decommissioning Plan  
Coyote Road Solar Project  
Tazewell County, Illinois**



Prepared for:  
Coyote Road Solar, LLC  
c/o RWE Solar Development, LLC  
353 N. Clark Street #3000  
Chicago, IL 60654

Prepared by:  
Stantec Consulting Services Inc.  
1165 Scheuring Road  
De Pere, Wisconsin 54115

Project No: 193709969  
March 4, 2024  
Revised March 9, 2026

This document entitled Decommissioning Plan – Coyote Road Solar Project, Tazewell County, Illinois, was prepared by Stantec Consulting Services Inc. (Stantec) for the use of Coyote Road Solar, LLC, c/o RWE Solar Development, LLC (the Client), and the applicable regulatory agencies. The material in this document reflects Stantec's professional judgment in light of the scope, schedule and other limitations stated in the document and in the contract between Stantec and the Client. The opinions in this document are based on conditions and information existing at the time this document was published and do not take into account any subsequent changes. In preparing the document, Stantec did not verify information supplied to it by others.



---

**Christiana Jansen**  
**Environmental Scientist**



---

**JoAnne J Blank**  
**Senior Associate, Senior Scientist**



---

**Matthew A Clementi, PE**  
**Senior Civil Engineer**

**PE CERTIFICATION**

**NAME:** Matthew Clementi  
**TITLE:** Professional Engineer  
**COMPANY:** Stantec Consulting Services Inc.  
**REGISTRATION NO:** #062049423  
**EXPIRATION:** 11/30/2027  
**STATE:** ILLINOIS

## Table of Contents

<b>1.0</b>	<b>INTRODUCTION</b> .....	<b>1</b>
1.1	SOLAR FACILITY COMPONENTS .....	1
1.2	TRIGGERING EVENTS AND EXPECTED LIFETIME OF PROJECT .....	1
1.3	DECOMMISSIONING SEQUENCE.....	2
<b>2.0</b>	<b>PROJECT COMPONENTS AND DECOMMISSIONING ACTIVITIES</b> .....	<b>3</b>
2.1	OVERVIEW OF SOLAR FACILITY SYSTEM .....	3
2.2	SOLAR MODULES.....	4
2.3	TRACKING SYSTEM AND SUPPORT.....	4
2.4	SOLAR INVERTER AND TRANSFORMER STATIONS .....	4
2.5	ELECTRICAL CABLING AND CONDUITS .....	4
2.6	PROJECT SUBSTATION AND BELOW GROUND TRANSMISSION LINE.....	5
2.7	CENTER PIVOT IRRIGATION SYSTEM ELECTRICAL CONNECTION .....	5
2.8	OPERATIONS AND MAINTENANCE BUILDING .....	6
2.9	PERIMETER FENCING, SITE ACCESS, AND INTERNAL ROADS .....	6
<b>3.0</b>	<b>LAND USE AND ENVIRONMENT</b> .....	<b>7</b>
3.1	SOILS AND AGRICULTURAL LAND.....	7
3.2	RESTORATION AND REVEGETATION .....	7
3.3	SURFACE WATER DRAINAGE AND CONTROL .....	7
3.4	MAJOR EQUIPMENT REQUIRED FOR DECOMMISSIONING .....	7
<b>4.0</b>	<b>DECOMMISSIONING COST ESTIMATE SUMMARY</b> .....	<b>8</b>
4.1	DECOMMISSIONING EXPENSES.....	8
4.2	DECOMMISSIONING REVENUES .....	9
4.3	DECOMMISSIONING COST SUMMARY .....	11
4.4	FINANCIAL ASSURANCE.....	11

### LIST OF TABLES

Table 1	Major Components of Solar Project to be Decommissioned .....	3
Table 2	Typical Access Road Construction Materials.....	6
Table 3	Estimated Decommissioning Expenses.....	9
Table 4	Estimated Decommissioning Revenues .....	10
Table 5	Net Decommissioning Cost Summary .....	11
Table 6	Decommissioning Cost Summary with Annual Inflation Factor .....	11

### LIST OF FIGURES

Figure 1 Proposed Project Layout

## 1.0 INTRODUCTION

Coyote Road Solar, LLC, c/o RWE Solar Development, LLC (Coyote Road Solar), is proposing to construct the Coyote Road Solar Project (the Project) in Tazewell County, Illinois. The proposed Project is located in Delavan and Malone Townships, west of Delavan, Illinois. The Project boundary encompasses approximately 1,300 acres with approximately 926 acres of land within perimeter fencing. The maximum nameplate generating capacity of the Project will be up to 150 megawatts (MW) alternating current (AC) at the point-of-interconnect (POI). Construction of the Project is planned to begin in mid-2026 with a Commercial Operation Date (COD) projected in mid-2027.

This Decommissioning Plan (Plan) has been prepared in accordance with:

- Requirement for a "Deconstruction Plan" from the Standard Agricultural Impact Mitigation Agreement (AIMA) between Coyote Road Solar, LLC and the Illinois Department of Agriculture (IDOA), executed February 23, 2024.
- The Tazewell County Ordinance Chapter 156: Solar Energy Systems and Chapter 157: Special Uses, as applicable to the decommissioning of solar energy systems (County Ordinance).
- Requirements of the landowner lease agreements (landowner agreements supersede AIMA, where allowed).

This Plan is applicable to the decommissioning/deconstruction and restoration phases of the Project. Coyote Road Solar will be the responsible party for decommissioning the Project. A summary of the components to be removed is provided in Section 1.1. A summary of estimated costs associated with decommissioning is included in Section 4.0.

### 1.1 SOLAR FACILITY COMPONENTS

Major components of the Project covered under this Plan include (also see Figure 1):

- Solar modules and tracking system
- Foundations and steel piles
- Inverter/transformer stations
- Electrical cabling and conduits
- Project substation
- Site access and internal roads
- Perimeter fencing

### 1.2 TRIGGERING EVENTS AND EXPECTED LIFETIME OF PROJECT

The following events could trigger the need for decommissioning:

- Section 17.B of the AIMA states, "The Facility Owner shall, at its expense, complete Deconstruction of a Facility within twelve (12) months after the end of the useful life of the Facility." The AIMA

provides that "a Commercial Solar Energy Facility shall be presumed to have reached the end of its useful life if the Commercial Solar Energy Facility Owner fails, for a period of six (6) consecutive months, to pay the Landowner amounts owed in accordance with an Underlying Agreement."

- Section 17.F of the AIMA also states, "Upon Abandonment, the County may take all appropriate actions for Deconstruction including drawing upon the Financial Assurance." Abandonment is defined in the AIMA as "when Deconstruction has not been completed within 12 months after the Commercial Solar Energy Facility reaches the end of its useful life."
- Section 156.06(B)12(b) of the County Ordinance states, "The facility owner shall, at its expense, completely decommission of a facility within 12 months after the end of the useful life of the facility."

The expected lifetime of the Project is approximately 40 years with limited equipment replacement and without repowering. Depending on market conditions and Project viability, the solar arrays may be retrofitted with updated components (e.g., modules, tracking system, etc.) to extend the life of the Project. In the event the modules are not retrofitted, or at the end of the Project's useful life, the modules and associated components will be decommissioned, and the site will be restored in accordance with this Plan, or an updated decommissioning plan agreed to by the Project and the applicable regulatory bodies at the time of decommissioning.

### **1.3 DECOMMISSIONING SEQUENCE**

In accordance with the AIMA, solar facility decommissioning will occur within twelve months after the end of the facility's useful life. The general sequence of decommissioning and removal is described below; however, overlap of activities is expected.

- Reinforce access roads, if needed, and prepare site for component removal.
- Install temporary fencing and erosion control best management practices (BMPs) to protect sensitive resources.
- De-energize solar arrays.
- Dismantle modules and racking.
- Remove frame and internal components.
- Remove structural foundations and piles and backfill sites.
- Remove inverter/transformer stations.
- Remove electrical cables and conduits above and below the ground surface to a depth of five feet.
- Remove access and internal roads and grade areas, as needed, or specified within landowner lease agreements.
- Remove substation, if decommissioned.
- De-compact subsoils (if required), restore and revegetate disturbed land as specified with the AIMA, landowner lease agreements, or permit conditions.
- Restore the soil depth and contours of the property as close as reasonably practicable to the conditions originally present prior to the Project.
- Repair damage to drain tile system.

## 2.0 PROJECT COMPONENTS AND DECOMMISSIONING ACTIVITIES

Project components and decommissioning activities are further described within this section.

### 2.1 OVERVIEW OF SOLAR FACILITY SYSTEM

The Project anticipates utilizing 387,180 solar modules, with an approximate total nameplate generating capacity of approximately 211.013 megawatts-direct current (DC) and up to 150.0 MW<sub>AC</sub>. The Project generating facilities will be placed within approximately 926 acres of land bounded by perimeter fencing as shown on Figure 1. The Project area is situated on predominantly agricultural land. Statistics and estimates provided in this Plan are based on a 545-watt bifacial module manufactured by RUNERGY.

Collection cabling will be installed below the surface at a depth of approximately four to five feet (48 to 60 inches). All collection cabling, foundations and steel piles will be removed during Project decommissioning. Access roads may be left in place if requested and/or agreed to by the landowner; however, for purposes of this assessment, all access roads are assumed to be removed and the land restored to pre-construction conditions. Public roads damaged or modified during the decommissioning and reclamation process will be repaired upon completion of the decommissioning phase.

Estimated quantities of materials to be removed and salvaged or disposed of are included in this section. Many of the materials described have salvage value; although, there are some components that will likely have none at the time of decommissioning. All materials will be salvaged or recycled to the extent possible. All other waste materials will be disposed of in accordance with state and federal law in an approved licensed solid waste facility.

Solar modules will have value in a resale market, decreasing over the life of the Project. For purposes of this report, salvage values only, not resale, were considered as this is the more conservative estimate strategy.

Table 1 presents a summary of the major Project components included in this Plan.

**Table 1 Major Components of Solar Project to be Decommissioned**

Component	Quantity	Unit of Measure
Solar modules	387,180	Each
Tracking system	3,585	Each
Steel piles (trackers)	68,602	Each
Inverter/transformer stations	40	Each
Steel piles/posts (inverter/transformer stations)	480	Each
Electrical cables and conduits (below ground cabling)	156,975	Linear Foot (estimated)
Perimeter fencing	73,353	Linear Foot
Access roads (approximate)	49,772	Linear Foot

<b>Component</b>	<b>Quantity</b>	<b>Unit of Measure</b>
Substation (1 transformer)	1	Each
Above ground generation tie-in transmission line removal	250 (0.05)	Linear Foot (Linear Mile)

## **2.2 SOLAR MODULES**

The Project is planning to use a 545-watt HY-DH144P8 bifacial module from RUNERGY or similar module for the Project. Each module assembly (with frame) has a total weight of approximately 70.5 pounds. The modules will be approximately 89.7 inches by 44.6 inches in size and are mainly comprised of an anodized aluminum frame and various non-metallic materials such as silicon, glass, plastic, and epoxies.

At the time of decommissioning, module components in working condition may be refurbished and sold in a secondary market yielding greater revenue than selling as salvage material.

## **2.3 TRACKING SYSTEM AND SUPPORT**

The solar modules will be mounted on a single-axis tracking system. Each full-sized tracker is approximately 411 feet in length and will support approximately 108 solar modules. Smaller trackers will be employed at the edges of the layout, to efficiently utilize available space. The tracking system is mainly comprised of galvanized and stainless steel; piles that support the system are assumed to be comprised of structural steel.

The solar arrays will be deactivated from the surrounding electrical system and made safe for disassembly. Liquid wastes, including oils and hydraulic fluids will be removed and properly disposed of or recycled according to regulations current at the time of decommissioning. Electronic components, and internal electrical wiring will be removed and salvaged. The steel piles will be completely removed from the ground.

The supports, tracking system, and posts contain salvageable materials which can be sold to provide revenue to offset the decommissioning costs.

## **2.4 SOLAR INVERTER AND TRANSFORMER STATIONS**

Inverters and medium voltage transformers generally sit on metal skids mounted on small concrete footings or steel piles within the array. The inverters and transformers will be deactivated, disassembled, and removed, along with metal skids and concrete footings. Depending on condition, the equipment may be sold for refurbishment and re-use. If not re-used, they will be salvaged or disposed of at an approved solid waste management facility.

## **2.5 ELECTRICAL CABLING AND CONDUITS**

The Project's underground electrical collection system will generally be placed at a depth of approximately four to five feet (48 to 60 inches) with exceptions where collection lines may cross under the utilities and under public roadways. This plan assumes collection and communications cabling will be removed and salvaged if buried at no more than five (5) feet below grade. No recovery value has been assumed for the collection cabling, although it is likely to have salvage value at the time of removal.

## **2.6 PROJECT SUBSTATION AND BELOW GROUND TRANSMISSION LINE**

The proposed Project includes a substation within an approximately one-acre footprint. The substation will include a gravel pad, power transformer and footings, electrical control house and concrete foundations, as needed. A dedicated above ground generation tie-in transmission line, anticipated to be approximately 250 feet in length, will connect the Project to an Ameren utility substation (switchyard). Unless an alternate use for the Project substation and transmission line are determined, the facilities will be removed, and the land restored to pre-construction condition to the extent practicable.

The substation transformer may be sold for re-use or salvage. Components of the substation that cannot be salvaged will be transported off-site for disposal at an approved waste management facility. Foundations and footings will be demolished and removed. The transmission line and associated structures will be removed. While there is a potential for the substation and transmission line to remain in use at the end of the Project life, an estimated decommissioning cost has been included in this Plan.

## **2.7 CENTER PIVOT IRRIGATION SYSTEM ELECTRICAL CONNECTION**

The proposed Project decommissioning estimate includes the re-installation cost associated with the center pivot irrigation system's three-phase underground electrical connection located on the Cotterman Family Trust Parcel (PID 21-21-30-400-004). The associated electrical supply lines will be removed during construction and operation of the Project. Therefore, it is desired by the Cotterman Family Trust that, upon future Project decommissioning, the electrical line to the irrigation system be reinstalled and re-connected to the Ameren power pole allowing restoration of the irrigation system and pre-construction agricultural land use.

It is understood that the Cotterman Parcel irrigation system is currently connected to an electrical line drop from the Coyote Road power pole with an underground electrical line approximately 1,400 feet long. The electrical line runs underground from the power pole on the south side of Coyote Road, under the road and right of way, and then continues within a 10-foot-wide Ameren easement on the Cotterman Parcel in a southwest to northeast direction from the edge of the road right of way to the irrigation center-pivot point where it is stepped-down from a primary voltage (~15kV) to a metered distribution voltage of 480V 3 phase power.

Coyote Road Solar has indicated that at the time of Project decommissioning, the direct bury electrical line currently located within the existing Ameren easement at a depth of 36 inches (three feet) or greater will be re-installed. The electrical line will be directionally bored under the Coyote Road right of way and resurface at an electrical pole on the south side of the road. The line will connect via a line drop from the Ameren distribution power pole. The existing line or conduit beneath Coyote Road may be able to be utilized; however, to be conservative, the cost of a directional bore to install the line beneath the road has been included in the total cost.

Upon completion of the electrical line installation, the trench will be refilled with soil reserved at the time of excavation, topsoil replaced, and the site stabilized with appropriate vegetation, if required and desired by the landowner at that time. The electrical line will terminate at the irrigation well control panel (if present). The estimated re-installation cost of the irrigation system electrical connection has been included in Table 3.

## 2.8 OPERATIONS AND MAINTENANCE BUILDING

The Project will utilize one operations and maintenance (O&M) structure within the Project site. The structure will be approximately 2,750 square feet and will be installed on a gravel pad with connections to electrical or other services, as needed. The structure will be in conformance with local and state building codes. Due to the size and value of the building at time of decommissioning, it is assumed to be sold or reverted back to the landowner for future use. Therefore, no costs for the demolition of the O&M building have been included in the estimate.

## 2.9 PERIMETER FENCING, SITE ACCESS, AND INTERNAL ROADS

The Project site will include a chain link fence around the perimeter of each array site. The perimeter fence will be removed from the Project site during decommissioning.

Access drives will provide direct access to the solar facility from local roads. Internal roads will be located within the array to allow access to the equipment. The access drive and internal access roads will be approximately 12 feet wide and total approximately 49,772 linear feet (9.4 miles). To be conservative, this estimate assumes that all access and internal roads will be removed during the decommissioning phase.

During installation of the Project site access and internal roads, native subgrade will be compacted, and 12 inches of cement stabilized soils will be placed beneath the gravel for the length of the access road. This Plan assumes the installation of up to six (6) inches of aggregate base materials over the cement stabilized base. The estimated quantity of these materials is provided in Table 2.

**Table 2 Typical Access Road Construction Materials**

Item	Quantity	Unit
Gravel or granular fill; 6-inch thick	11,060	Cubic Yards
Cement stabilization	22,121	Cubic Yards

Decommissioning activities include the removal and stockpiling of aggregate materials onsite for salvage preparation. Underlying cement stabilized soils will be broken up and removed, to an extent practicable, during the decommissioning process. Following removal of aggregate, the access road areas will be graded, de-compacted with deep ripper or chisel plow (ripped to 18 inches), backfilled with native subsoil and topsoil, as needed, and land restored as near as practicable to preconstruction conditions.

## **3.0 LAND USE AND ENVIRONMENT**

### **3.1 SOILS AND AGRICULTURAL LAND**

Areas of the Project that were previously utilized for agricultural purposes will be restored, as close as reasonably practical, to their preconstruction condition in accordance with the AIMA and landowner lease agreements. Soil conditions shall also be restored to their pre-construction soil fertility, unless the soil fertility when the restoration term is triggered is superior to the pre-construction soil fertility. Restored areas will be revegetated in consultation with the current landowner and in compliance with regulations in place at the time of decommissioning. Land disturbed by Project facilities will be restored in such a way to be used in a reasonably similar manner to its original intended use as it existed prior to Project construction.

### **3.2 RESTORATION AND REVEGETATION**

Areas of the Project that have been excavated and backfilled will be graded as previously described to restore land as required within landowner lease agreements. Soils compacted during decommissioning activities will be de-compacted, as necessary, to restore the land as close as reasonably practical to pre-construction depth and contour. If present, drain tiles that have been damaged will be restored to pre-construction condition, as described condition 6.D of the AIMA. Topsoil will be placed on disturbed areas and seeded with appropriate vegetation or in coordination with landowners within agricultural land.

### **3.3 SURFACE WATER DRAINAGE AND CONTROL**

The Project area is predominantly located in actively drained agricultural land. The terrain is relatively flat with several man-made and natural drainages. The Project facilities have been sited to avoid wetlands, waterways, and drainage ditches to the extent practicable. The existing Project site conditions and proposed BMPs to protect surface water features will be detailed in a Project Stormwater Pollution Prevention Plan (SWPPP) prior to the commencement of deconstruction activities.

Surface water conditions at the Project site will be reassessed prior to the decommissioning phase. Coyote Road Solar will obtain the required water quality permits from the Illinois Department of Natural Resources (IDNR) and the U.S. Army Corp of Engineers (USACE), if needed, before decommissioning of the Project. Construction stormwater permits will also be obtained and a SWPPP prepared describing the protection needed to reflect conditions present at the time of decommissioning. BMPs may include improved construction entrances, temporary seeding, permanent seeding, mulching (in non-agricultural areas), erosion control matting, silt fence, filter berms, and filter socks.

### **3.4 MAJOR EQUIPMENT REQUIRED FOR DECOMMISSIONING**

Equipment required for the decommissioning activities is similar to what is needed to construct the solar facility and may include, but is not limited to: small cranes, low ground pressure (LGP) tracked excavators, backhoes, LGP tracked bulldozers and dump trucks, front-end loaders, deep rippers, water trucks, disc plows and tractors to restore subgrade conditions, and ancillary equipment. Standard dump trucks may be required to transport material removed from the site to disposal facilities.

## **4.0 DECOMMISSIONING COST ESTIMATE SUMMARY**

Expenses associated with decommissioning the Project will be dependent on labor costs at the time of decommissioning. For the purposes of this report approximate 2026 market values were used to estimate labor expenses. Fluctuation and inflation of the labor costs were not factored into the estimates.

The value of the individual components of the solar facility will vary with time. In general, the highest component value would be expected at the time of construction with declining value over the life of the Project. Over most of the life of the Project, components such as the solar modules could be sold in the wholesale market for reuse or refurbishment. As efficiency and power production of the modules decrease due to aging and/or weathering, the resale value will decline accordingly. Secondary markets for used solar components include other utility scale solar facilities with similar designs that may require replacement equipment due to damage or normal wear over time; or other buyers (e.g., developers, consumers) that are willing to accept a slightly lower power output in return for a significantly lower price point when compared to new equipment.

### **4.1 DECOMMISSIONING EXPENSES**

Project decommissioning and deconstruction of facilities will incur costs associated with disposal of components not sold for salvage, including materials which will be disposed of at a licensed facility, as required. Table 3 summarizes the estimates for activities associated with the major components of the Project. The total estimated decommissioning cost in Table 3 also covers costs for backfilling, grading and restoration as described in Section 2.0.

**Table 3 Estimated Decommissioning Expenses**

Activity	Unit	Quantity	Cost per Unit	Total
Overhead and management (includes estimated permitting required)	Lump Sum	1	\$841,500	\$841,500
Solar modules; disassembly and removal*	Each	387,180	\$5.45	\$2,110,131
Tracking system disassembly and removal (equivalent 108-module trackers)	Each	3,585	\$850	\$3,047,250
Steel pile/post removal (trackers)	Each	68,602	\$13	\$891,826
Underground collection cables	Linear foot	156,975	\$0.95	\$149,126
Inverter/transformer stations	Each	40	\$1,980	\$79,200
Steel piles/posts removal (inverter/transformer stations)	Each	480	\$54.90	\$26,352
Perimeter fence removal	Linear Foot	73,353	\$4.70	\$344,759
Access road; excavation and removal	Lump Sum	1	\$565,400	\$565,400
Topsoil; replacement and rehabilitation of site including access roads	Lump Sum	1	\$778,750	\$778,750
Above ground generation tie-in transmission line removal	Linear Mile	0.05	\$275,000	\$13,750
Substation (1 transformer) removal	Lump Sum	1	\$330,000	\$330,000
Re-installation of a center pivot irrigation system 3-phase underground electrical connection	Lump Sum	1	\$78,000	\$78,000
<b>Total Estimated Decommissioning Cost</b>				<b>\$9,256,044</b>

\* Cost of equipment removal would be higher if retaining for resale rather than salvage; however, the increased revenue would offset the added removal costs.

## 4.2 DECOMMISSIONING REVENUES

Revenue from decommissioning the Project will be realized through the sale of the solar facility components and construction materials. As previously described, the value of the decommissioned components will be higher in the early stages of the Project and decline over time. Resale of components such as solar modules is expected to be greater than salvage (i.e., scrap) value for most of the life of the Project.

Modules and other solar plant components can be sold within a secondary market for re-use. A current sampling of reused solar modules indicates a wide range of pricing depending on age and condition (\$0.10 to \$0.30 per watt). Future pricing of solar modules is difficult to predict at this time, due to the relatively young age of the market, changes to solar module technology, and the ever-increasing product demand. A conservative estimation of the value of solar modules at \$0.10 per watt would yield approximately \$21,101,300. Increased costs of removal, for resale versus salvage, would be expected in order to preserve

the integrity of the modules; however, the net revenue would be substantially higher than the estimated salvage value.

The resale value of components, such as trackers, may decline more quickly; however, the salvage value of the steel that makes up a large portion of the tracker is expected to stay at or above the value used in this report.

The market value of steel and other materials fluctuates daily and has varied widely over the past five years. Salvage value estimates were based on an approximate five-year-average price of steel and copper derived from sources including on-line recycling companies and United States Geological Survey (USGS) commodity summaries. The price used to value the steel used in this report is \$283 per metric ton; aluminum at \$0.45 per pound; silicon at \$0.40 per pound and glass at \$0.05 per pound.

The main component of the tracking system and piles is assumed to be salvageable steel. Solar modules are estimated to contain approximately 75 percent glass, 8 percent aluminum and 5 percent silicon. A 50 percent recovery rate was assumed for aluminum and all modules components, due to the processing required to separate the module components. Alternative and more efficient methods of recycling solar modules are anticipated before this Project is decommissioned, given the large number of solar facilities that are currently being developed. Table 4 summarizes the potential salvage value for the solar array components and construction materials.

**Table 4 Estimated Decommissioning Revenues**

Item	Unit of Measurement	Quantity per Unit	Salvage Price per Unit	Total Salvage Price per Item	Number of Items	Total
Modules – Silicon	Average Pounds per Module	1.8	\$0.40	\$0.720	387,180	\$278,770
Modules - Aluminum	Average Pounds per Module	2.8	\$0.45	\$1.260	387,180	\$487,847
Modules - Glass	Average Pounds per Module	26.5	\$0.05	\$1.325	387,180	\$513,014
Tracking System and Posts	Tons per MW <sub>DC</sub>	32.0	\$283	\$9,056	211.013	\$1,910,934
Substation Components (steel and transformer)	Each	1.0	\$50,000	\$50,000	1	\$50,000
<b>Total Potential Revenue*</b>						<b>\$3,240,565</b>

\*Revenue based on salvage value only. Revenue from used modules at \$0.10 per watt could raise \$21,101,300 as resale versus the estimated salvage revenue.

### 4.3 DECOMMISSIONING COST SUMMARY

Table 5 provides a summary of the net estimated cost to decommission the Project, using the information detailed in Sections 4.1 and 4.2. Estimates are based on 2026 prices, with no market fluctuations or inflation considered.

**Table 5 Net Decommissioning Cost Summary**

Item	(Cost)/Revenue
Decommissioning Expenses	(\$9,256,044)
Potential Revenue – salvage value of module components and other recoverable materials	\$3,240,565
<b>Net Decommissioning Cost</b>	<b>(\$6,015,479)</b>

### 4.4 FINANCIAL ASSURANCE

The County Ordinance states that financial assurance to cover the end-of-life cost is required. The ordinance states the cost estimate shall be phased over the life of the project and increases at the inflation rate of the higher of either 2.5% or the average inflation rate of CPI-U of the three prior calendar years, at the time of approval. Currently the average inflation rate of CPI-U per the U.S. Bureau of labor statistics exceeds 5.0% annually and the CPI has a 3.3% three-year rate. The inflation rate over the past three years is not indicative of historic inflation rates; therefore, the 2.5% annual inflation rate was used in Table 6 below to more accurately represent the expected average inflation rate over the life of the Project.

**Table 6 Decommissioning Cost Summary with Annual Inflation Factor**

Description	Cost
Net Decommissioning Cost	\$6,015,479
First Anniversary of Project Commissioning (2.5% Annual Increase)	\$6,165,866
Second Anniversary of Project Commissioning (2.5% Annual Increase)	\$6,320,013
Third Anniversary of Project Commissioning (2.5% Annual Increase)	\$6,478,013
Fourth Anniversary of Project Commissioning (2.5% Annual Increase)	\$6,639,963
Fifth Anniversary of Project Commissioning (2.5% Annual Increase)	\$6,805,962
Tenth Anniversary of Project Commissioning (2.5% Annual Increase)	\$7,700,322
Fifteenth Anniversary of Project Commissioning (2.5% Annual Increase)	\$8,712,207

<b>Description</b>	<b>Cost</b>
Twentieth Anniversary of Project Commissioning (2.5% Annual Increase)	\$9,857,063
Twenty-fifth Anniversary of Project Commissioning (2.5% Annual Increase)	\$11,152,362
Thirtieth Anniversary of Project Commissioning (2.5% Annual Increase)	\$12,617,874
Thirty-fifth Anniversary of Project Commissioning (2.5% Annual Increase)	\$14,275,966
Fortieth Anniversary of Project Commissioning (2.5% Annual Increase)	\$16,151,945
<b>Financial Assurance Anniversary Dates of the Commercial Operation Date</b>	
<b>First Anniversary – Ten Percent (10%) of Fortieth Anniversary Cost</b>	<b>\$1,615,195</b>
<b>Sixth Anniversary – Fifty Percent (50%) of Fortieth Anniversary Cost</b>	<b>\$8,075,973</b>
<b>Tenth Anniversary – One Hundred Percent (100%) of Fortieth Anniversary Cost</b>	<b>\$16,151,945</b>

In compliance with the County requirements, Coyote Road Solar is providing this Decommissioning (Deconstruction) Plan prior to issuance of the County building permit. Coyote Road Solar understands that the County may require the Plan be updated on or before the end of the tenth year of commercial operation, and every five years thereafter.

Coyote Road Solar has indicated they will provide the County with Financial Assurance to cover the estimated costs of decommissioning. The provisions of this Financial Assurance shall be phased in over the first 11 years of the Project's operation as follows and as summarized in Table 6:

- On or before the first anniversary of the COD, Coyote Road Solar shall provide the County with Financial Assurance to cover ten (10) percent of the estimated costs to decommission the facility as determined in this Plan.
- On or before the sixth anniversary of the COD, Coyote Road Solar shall provide the County with Financial Assurance to cover fifty (50) percent of the estimated costs to decommission the facility as determined in this Plan.
- On or before the eleventh anniversary of the COD, Coyote Road Solar shall provide the County with Financial Assurance to cover one hundred (100) percent of the estimated costs to decommission the facility as determined in the updated Decommissioning Plan provided during the tenth year of commercial operation.

## FIGURES

Figure 1 Proposed Project Layout

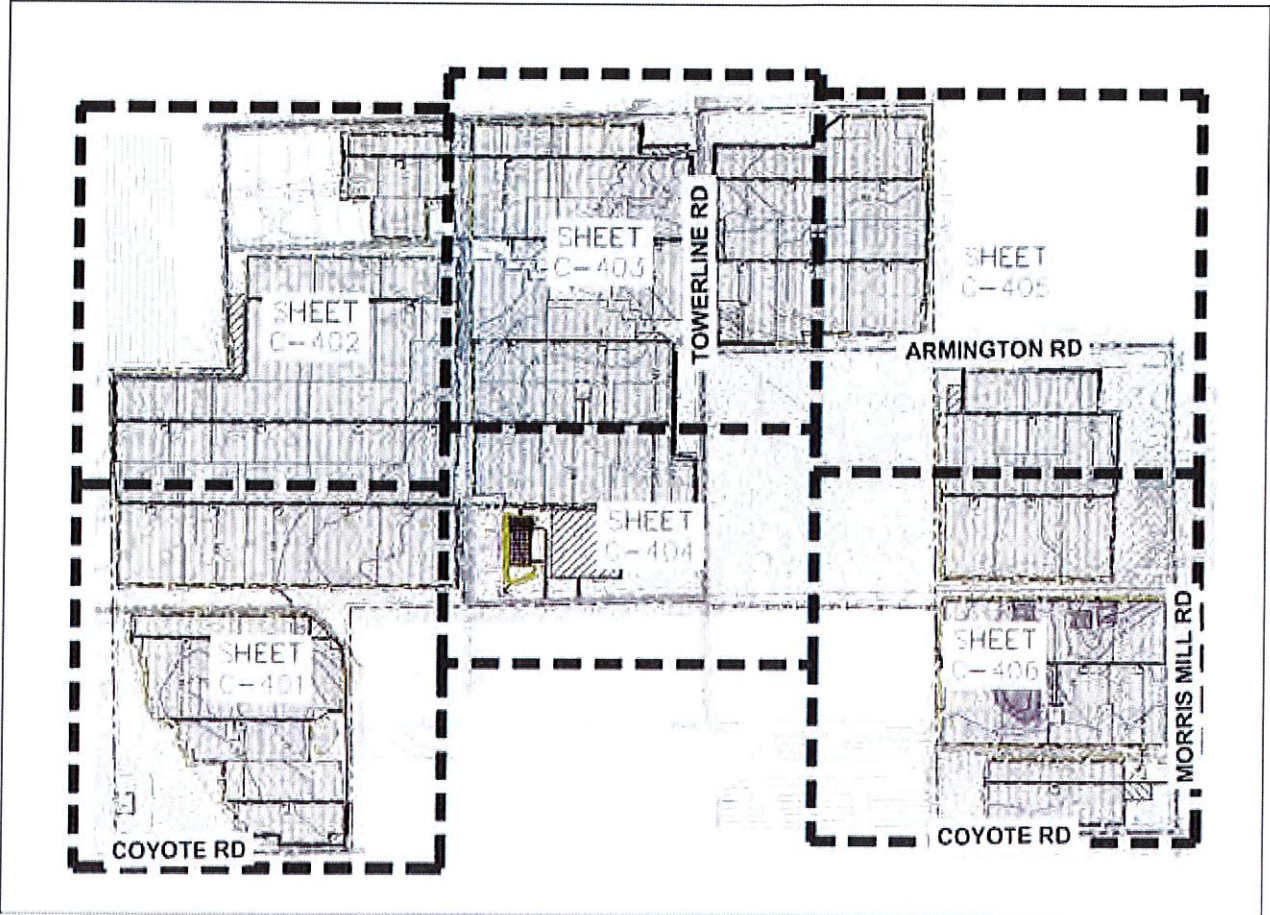

**COMMITTEE REPORT**

Mr. Chairman and Members of the Tazewell County Board:

Your Executive Committee has considered the following RESOLUTION and recommends that it be adopted by the Board:

---

**RESOLUTION**

WHEREAS, the County’s Executive Committee recommends to the County Board to approve the attached Road Use Agreement ,1<sup>st</sup> Amendment for Fast Ave Solar, LLC; and

WHEREAS, the 4.99 MW solar farm was approved by the Zoning Board of Appeals for Special Use on July 24<sup>th</sup>, 2024 to be located on approximately 37.67 acres located at 33885 Fast Ave in Mackinaw Township; and

WHEREAS, the County Board Approved the full Road Use Agreement September 26<sup>th</sup>, 2025; and

WHEREAS, the plan has been reviewed and approved by both the Mackinaw Township Road Commissioner and the Tazewell County Highway Engineer.

THEREFORE BE IT RESOLVED that the County Board approve this recommendation

BET IT FURTHER RESOLVED that the County Clerk Notified the County Board Office, Community Development, and the Auditor of this action.

PASSED THIS 25<sup>th</sup> DAY of March, 2026.

ATTEST:

  
Tazewell County Clerk

  
Tazewell County Board Chairman

## FIRST AMENDMENT TO ROAD USE AGREEMENT

This FIRST AMENDMENT TO ROAD USE AGREEMENT (“First Amendment”) is entered into as of **January \_\_, 2026** (the “Effective Date”) by and between **FAST AVE SOLAR LLC**, an Illinois limited liability company (“Owner”), **MACKINAW ROAD DISTRICT**, acting through its Highway Commissioner for the use of approximately one quarter mile of Fast Ave Solar (Township Road 99) for access during construction and maintenance of a solar farm (“Road District”), and **TAZEWELL COUNTY, ILLINOIS**, a body corporate and politic acting by and through its Board (the “County”), for the use of approximately one half mile of Lilly Road, for access to the proposed location during the construction of a solar farm (“Project”) located at PIN 13-13-14-400-004 with an address of 33885 Fast Ave; Mackinaw, IL; 61755 (Owner, Road District, and County, each a “Party”, and collectively, the “Parties”).

### RECITALS:

WHEREAS, the Parties executed the Road Use Agreement dated as of October 29, 2025 (the “Agreement”), which Agreement provided that Tazewell County would permit Owner access to the solar farm from Lilly Road for the construction of the Project and Mackinaw Road District would permit access for long term maintenance of the Project (not construction traffic), from Fast Avenue;

WHEREAS, the design of the Project includes a permanent access road from Fast Avenue, such that the intended use of the permanent access road from Fast Avenue has changed;

WHEREAS, as a result of the changed use of the permanent access road from Fast Avenue, certain provisions of the Agreement need to be changed.

WHEREAS, the Parties desire to enter into this First Amendment to (i) allow Owner to utilize the permanent access road from Fast Avenue for the delivery of transformers to the Project, and (ii) allow Owner to utilize the permanent access road from Fast Avenue for the delivery of rock associated with the permanent access road.

NOW, THEREFORE, the Parties agree to the following, as of the Effective Date:

1. The Agreement shall be amended as follows:
  - ❑. Section 2 shall read as follows: “Tazewell County will permit access to the solar farm from Lilly Road for the construction of the Project as shown below in Exhibit B and Mackinaw Road District will permit access to the solar farm from Fast Avenue only for long term maintenance of the Project, the delivery of transformers to the Project, and the delivery of rock for the permanent access road.”
  - ❑. In Exhibit A, the words “The permanent project entrance on Fast Avenue will only be used for Utility access, as well as maintenance visits once the project is in

operation.” shall be replaced with “The permanent project entrance on Fast Avenue will only be used for Utility access, delivering transformers and rocks, and maintenance visits once the project is in operation.”

2. Each of the individuals executing this First Amendment on behalf of a Party individually represents and warrants that he or she has been authorized to do so and has the power to bind the party for whom they are signing.
3. This First Amendment may be executed in any number of counterparts, and by the different Parties in separate counterparts, each of which when executed shall be deemed to be an original, and all of which, taken together, shall be deemed to constitute one and the same instrument. Electronic delivery of an executed counterpart of a signature page to this First Amendment shall be effective as delivery of an original executed counterpart of this First Amendment.
4. Except as amended hereby, all terms and conditions of the Agreement shall remain in full force and effect. Terms and conditions used but not defined herein shall have the meaning set forth in the Agreement.

[signatures follow]

IN WITNESS WHEREOF, the Parties have executed this First Amendment as of the date set forth above.

**FAST AVENUE SOLAR LLC,**  
an Illinois limited liability company

By: \_\_\_\_\_  
Name: Rafael Dobrzynski  
Title: CEO and President

**TAZEWELL COUNTY, ILLINOIS,**  
a body corporate and politic

By: \_\_\_\_\_  
Name:  
Title:

**MACKINAW ROAD DISTRICT**

By: \_\_\_\_\_  
Name:  
Title:

**REAPPOINTMENT**

I, Brett Grimm, Chairman of the Tazewell County (Illinois) Board, hereby reappoint Michael L. Morris of 1401 California Road, Pekin, IL 61554 to the Brush Hill Fire Protection District for a term commencing May 05, 2026 and expiring May 07, 2029.

---

**COMMITTEE REPORT**

TO: Tazewell County Board  
FROM: Executive Committee

This Committee has reviewed the reappointment of Michael L. Morris to the Brush Hill Fire Protection District and we recommend said reappointment be approved.

---

**RESOLUTION OF APPROVAL**

The Tazewell County Board hereby approves the reappointment of Michael L. Morris to the Brush Hill Fire Protection District.

The County Clerk shall notify the County Board Office and the County Board Office will notify the Bagley and Miller Law Office of this action.

PASSED THIS 25<sup>th</sup> DAY OF MARCH, 2026.

ATTEST:

  
Tazewell County Clerk

  
Tazewell County Board Chairman

**REAPPOINTMENT**

I, Brett Grimm, Chairman of the Tazewell County (Illinois) Board, hereby reappoint Todd Mundorf of the Powerton Power Plant, 13082 E. Manito Road, Pekin, IL 61554 to the Powerton Fire Protection District for a term commencing May 5, 2026 and expiring May 07, 2029.

---

**COMMITTEE REPORT**

TO: Tazewell County Board  
FROM: Executive Committee

This Committee has reviewed the reappointment of Todd Mundorf to the Powerton Fire Protection District and we recommend said reappointment be approved.

---

**RESOLUTION OF APPROVAL**

The Tazewell County Board hereby approves the reappointment of Todd Mundorf to the Powerton Fire Protection District.

The County Clerk shall notify the County Board Office and the County Board Office will notify the Bagley and Miller Law Office of this action.

PASSED THIS 25<sup>th</sup> DAY OF MARCH, 2026.

ATTEST:

  
\_\_\_\_\_  
Tazewell County Clerk

  
\_\_\_\_\_  
Tazewell County Board Chairman

**REAPPOINTMENT**

I, Brett Grimm, Chairman of the Tazewell County (Illinois) Board, hereby reappoint K. Russell Crawford of 204 District Court, East Peoria, IL 61611 to the Tri-County Regional Planning Commission Board for a term commencing December 01, 2025 and expiring November 30, 2026.

---

**COMMITTEE REPORT**

TO: Tazewell County Board  
FROM: Executive Committee

This Committee has reviewed the reappointment of K. Russell Crawford to the Tri-County Regional Planning Commission and we recommend said reappointment be approved.

---

**RESOLUTION OF APPROVAL**

The Tazewell County Board hereby approves the reappointment of K. Russell Crawford to the Tri-County Regional Planning Commission.

The County Clerk shall notify the County Board Office and the County Board Office will notify Tri-County Regional Planning Commission of this action.

PASSED THIS 25<sup>th</sup> DAY OF MARCH, 2026.

ATTEST:

  
\_\_\_\_\_  
Tazewell County Clerk

  
\_\_\_\_\_  
Tazewell County Board Chairman

**APPOINTMENT**

I, Brett Grimm, Chairman of the Tazewell County (Illinois) Board, hereby appoint Jon Hopkins of 1060 Johnson Street, Morton, IL to the Veterans Assistance Commission for a term commencing March 26, 2026 and expiring March 25, 2027.

---

**COMMITTEE REPORT**

TO: Tazewell County Board  
FROM: Executive Committee

This Committee has reviewed the appointment of Jon Hopkins to the Veterans Assistance Commission and we recommend said appointment be approved.

---

**RESOLUTION OF APPROVAL**

The Tazewell County Board hereby approves the appointment of Jon Hopkins to the Veterans Assistance Commission.

The County Clerk shall notify the County Board Office and the County Board Office will notify the VAC Superintendent of this action.

PASSED THIS 25<sup>th</sup> DAY of MARCH, 2026.

ATTEST:

  
\_\_\_\_\_  
Tazewell County Clerk

  
\_\_\_\_\_  
Tazewell County Board Chairman

**REAPPOINTMENT**

I, Brett Grimm, Chairman of the Tazewell County (Illinois) Board, hereby reappoint Richard Schwab of 101 Scenic Bluff, East Peoria, IL to the Board of Review for a term commencing June 1, 2026 and expiring May 31, 2028.

---

**COMMITTEE REPORT**

To: Tazewell County Board  
From: Executive Committee

The Committee has reviewed the reappointment of Richard Schwab to the Board of Review, and we recommend said reappointment to be approved.

---

**RESOLUTION OF APPROVAL**

The Tazewell County Board hereby approves the reappointment of Richard Schwab to the Board of Review.

The County Clerk shall notify the County Board Office, and the County Board Office will notify the County Board Chairman of this action.

PASSES THIS 25<sup>TH</sup> DAY OF March, 2026.

ATTEST:

  
\_\_\_\_\_  
Tazewell County Clerk

  
\_\_\_\_\_  
Tazewell County Board Chairman

**REAPPOINTMENT**

I, Brett Grimm, Chairman of the Tazewell County (Illinois) Board, hereby reappoint Greg Sinn of 607 Locust St, Tremont, IL 61568 to the Farmland Assessment Review Committee for a term commencing May 1, 2026 and expiring April 30, 2028.

---

**COMMITTEE REPORT**

To: Tazewell County Board  
From: Executive Committee

The Committee has reviewed the reappointment of Greg Sinn to the Farmland Assessment Review Committee, and we recommend said reappointment to be approved.

---

**RESOLUTION OF APPROVAL**

The Tazewell County Board hereby approves the reappointment of Greg Sinn to the Farmland Assessment Review Committee.

The County Clerk shall notify the County Board Office, and the County Board Office will notify the County Board Chairman of this action.

PASSES THIS 25<sup>TH</sup> DAY OF March, 2026.

ATTEST:

  
\_\_\_\_\_  
Tazewell County Clerk

  
\_\_\_\_\_  
Tazewell County Board Chairman

**REAPPOINTMENT**

I, Brett Grimm, Chairman of the Tazewell County (Illinois) Board, hereby reappoint Michael Deppert, 112 Country Drive, Green Valley, IL 61534 to the Farmland Assessment Review Committee for a term commencing June 1, 2026 and expiring May 31, 2028.

---

**COMMITTEE REPORT**

To: Tazewell County Board  
From: Executive Committee

The Committee has reviewed the reappointment of Michael Deppert to the Farmland Assessment Review Committee, and we recommend said reappointment to be approved.

---

**RESOLUTION OF APPROVAL**

The Tazewell County Board hereby approves the reappointment of Michael Deppert to the Farmland Assessment Review Committee.

The County Clerk shall notify the County Board Office, and the County Board Office will notify the County Board Chairman of this action.

PASSES THIS 25<sup>TH</sup> DAY OF March, 2026.

ATTEST:



Tazewell County Clerk



Tazewell County Board Chairman