

Tazewell County Highway Department

AUTHORIZATION TO BID FORM

Addenda will be published to our Bid Letting page in the same manner as the plans and specifications. It is the sole responsibility of the plan holders to periodically check the website for plan addenda.

ALL BIDDERS PLANNING TO PLACE A BID MUST FILL OUT THIS FORM TO BE AUTHORIZED TO BID.

- This form must be completed, signed and either faxed to (309) 925-5533 or emailed to jsciortino@tazewell-il.gov.
- Failure to submit this completed form will result in the bid not being accepted.
- Contractors may verify we have received their Authorization to Bid form by checking the **Plan Holders List** found under the corresponding letting date.
- If an email address is provided, a Notice of Addenda will be sent when updates are available.
- Bid results are typically posted by noon on the day of the letting and are preliminary until approved by the County Board on the last Wednesday of the month.

Company Name:	
Address:	
Phone:	
Fax:	
Email:	
Bid Letting Date:	

Projects Intending to Bid on:

Section Number:	Description:

Proposal Submitted By:

Contractor's Name

Contractor's Address

City

State

Zip Code

STATE OF ILLINOIS

Local Public Agency

County

Section Number

Street Name/Road Name

Type of Funds

Material proposal Deliver and Install Proposal Plans

For a County and Road District Project

Submitted/Approved

Highway Commissioner Signature & Date

Submitted/Approved

County Engineer/Superintendent of Highways Signature & Date
Dan Parr Digitally signed by Dan Parr
 Date: 2026.03.24 08:18:38
 -05'00'

For a Municipal Project

Submitted/Approved/Passed

Signature & Date

Official Title

Department of Transportation

Released for bid based on limited review

Regional Engineer Signature & Date

Note: All proposal documents, including Proposal Guaranty Checks or Proposal Bid Bonds, should be stapled together to prevent loss when bids are processed.

Local Public Agency

Heritage Lake Special Service Area

County

Tazewell

Section Number

2026 SEAL COAT

NOTICE TO BIDDERS

Sealed proposals for the project described below will be received at the office of The Tazewell County Engineer

		Name of Office	
<u>21308 Illinois Route 9</u>	<u>Tremont, Illinois 61568</u>	until <u>1:30 PM</u>	on <u>04/16/26</u>
Address		Time	Date

1. Plans and proposal forms will be available in the office of

<p>The Tazewell County Engineer 21308 Illinois Route 9, Tremont, Illinois 61568</p>

2. Prequalification

If checked, the 2 low bidders must file within 24 hours after the letting an "Affidavit of Availability" (Form BC 57) in duplicate, showing all uncompleted contracts awarded to them and all low bids pending award for Federal, State, County, Municipal and private work. One original shall be filed with the Awarding Authority and one original with the IDOT District Office.

- The Awarding Authority reserves the right to waive technicalities and to reject any or all proposals as provided in BLRS Special Provision for Bidding Requirements and Conditions for Material/Deliver and Install Proposals.
- A proposal guaranty in the proper amount, as specified in the BLRS Special Provision for Bidding Requirements and Conditions for Material/Deliver and Install Proposals, will be required. See the attached Special Provisions for specific instructions for proposal guaranty for this proposal packet.
- The successful bidder at the time of execution of the contract will be required to deposit a contract bond or proposal guaranty as provided for in the special provisions. Failure on the part of the contractor to deliver the material within the time specified or to do the work specified herein will be considered just cause to forfeit his surety as provided in Article 108.10 of the Standard Specifications.
- Proposals shall be submitted on forms furnished by the Awarding Authority and shall be enclosed in an envelope endorsed "Material Proposal, Section 2026 SEAL COAT".

By Order of

Awarding Authority

Tazewell County Board

County Engineer/Superintendent of Highways/
Municipal Clerk

Dan Parr, Tazewell County Engineer	Date 03/24/26
------------------------------------	------------------

Material Proposal or Deliver & Install Proposal

To

Awarding Authority

Tazewell County Board

Awarding Authority Address

11 South 4th Street

City

Pekin

State

IL

Zip Code

61554

If this bid is accepted within 45 days from the date of opening, the undersigned agrees to furnish or to deliver & install any or all of the materials, at the quoted unit prices, subject to the following:

- It is understood and agreed that the "Standard Specifications for Road and Bridge Construction", adopted 01/01/22 and the "Supplemental Specifications and Recurring Special Provisions", adopted 01/01/26, prepared by the Department of Transportation, shall govern insofar as they may be applied and insofar as they do not conflict with the special provision and supplemental specifications attached hereto.
- It is understood that quantities listed are approximate only and that they may be increased or decrease as may be needed to properly complete the improvement within its present limits or extensions thereto, at the unit prices stated and that bids will be compared on the basis of total price bid for each group.
- Delivery in total or partial shipments as ordered shall be made within the time specified in the special provisions or by the acceptance at the point and in the manner specified in the "Schedule of Prices". If delivery on the job site is specified, it shall mean any place or paces on the road designed by the awarding authority or its authorized representative.
- The contractor and/or local public agency performing the actual material placement operations shall be responsible for providing work zone traffic control, unless otherwise specified in this proposal. Such devices shall meet the requirements of and be installed in accordance with applicable provisions of the "Illinois Manual on Uniform Traffic Control Devices" and any referenced Illinois Highway Standards.

Local Public Agency

County

Section Number

Heritage Lake Special Service Area

Tazewell

2026 SEAL COAT

- 5. Each pay item should have a unit price and a total price. If no total price is shown or if there is a discrepancy between the product of the unit price multiplied by the quantity, the unit price shall govern. If a unit price is omitted, the total price will be divided by the quantity in order to establish a unit price. A bid will be declared unacceptable if neither a unit price nor a total price is shown.
- 6. A proposal guaranty in the proper amount, as specified in BLRS Special Provision for Bidding Requirements and Conditions for Contract Proposals, will be required. The proposal guaranty as specified in the special provisions is attached.

If a bid bond is allowed or required, Department form BLR 12230 or a proposal guaranty check, complying with the specifications, made payable to: County Treasurer of Tazewell County.

The amount of the check is _____ (_____).

Attach Cashier's Check or Certified Check Here

In the event that one proposal guaranty check is intended to cover two or more bid proposals, the amount must be equal to the sum of the proposal guaranties which would be required for each individual bid proposal. If the proposal guaranty check is place in another bid proposal, state below where it may be found.

The proposal guaranty check will be found in the bid proposal for: Section Number _____).

Discounts will be allowed for payment as follows: 0% 0 calendar days 0% 0 calendar days

Discounts will not be considered in determining the low bidder

Bidder

By

Title

Address

City

State

Zip Code



Local Public Agency Heritage Lake Subdivision Special Service Area	County Tazewell	Section Number 2026 SEAL COAT
---	--------------------	----------------------------------

WE, _____ as PRINCIPAL, and _____ as SURETY, are held jointly,

severally and firmly bound unto the above Local Public Agency (hereafter referred to as "LPA") in the penal sum of 5% of the total bid price, or for the amount specified in the proposal documents in effect on the date of invitation for bids, whichever is the lesser sum. We bind ourselves, our heirs, executors, administrators, successors, and assigns, jointly pay to the LPA this sum under the conditions of this instrument.

WHEREAS THE CONDITION OF THE FOREGOING OBLIGATION IS SUCH that, the said PRINCIPAL is submitting a written proposal to the LPA acting through its awarding authority for the construction of the work designated as the above section.

THEREFORE if the proposal is accepted and a contract awarded to the PRINCIPAL by the LPA for the above designated section and the PRINCIPAL shall within fifteen (15) days after award enter into a formal contract, furnish surety guaranteeing the faithful performance of the work, and furnish evidence of the required insurance coverage, all as provided in the "Standard Specifications for Road and Bridge Construction" and applicable Supplemental Specifications, then this obligation shall become void; otherwise it shall remain in full force and effect.

IN THE EVENT the LPA determines the PRINCIPAL has failed to enter into a formal contract in compliance with any requirements set forth in the preceding paragraph, then the LPA acting through its awarding authority shall immediately be entitled to recover the full penal sum set out above, together with all court costs, all attorney fees, and any other expense of recovery.

IN TESTIMONY WHEREOF, the said PRINCIPAL and the said SURETY have caused this instrument to be signed by their respective officers this _____ of _____ Day _____ Month and Year

Principal

Company Name

Company Name

Signature & Date
By: _____

Signature & Date
By: _____

Title

Title

(If Principal is a joint venture of two or more contractors, the company names, and authorized signatures of each contractor must be affixed.)

Surety

Name of Surety

Signature of Attorney-in-Fact Signature & Date
By: _____

STATE OF IL
COUNTY OF

I _____, a Notary Public in and for said county do hereby certify that

(Insert names of individuals signing on behalf of PRINCIPAL & SURETY)

who are each personally known to me to be the same persons whose names are subscribed to the foregoing instrument on behalf of PRINCIPAL and SURETY, appeared before me this day in person and acknowledged respectively, that they signed and delivered said instruments as their free and voluntary act for the uses and purposes therein set forth.

Given under my hand and notarial seal this _____ day of _____ Month and Year .

(SEAL, if required by the LPA)

Notary Public Signature & Date

Date commission expires _____

Local Public Agency

County

Section Number

Heritage Lake Subdivision Special Service Area

Tazewell

2025 SEAL COAT

ELECTRONIC BID BOND

Electronic bid bond is allowed (box must be checked by LPA if electronic bid bond is allowed)

The Principal may submit an electronic bid bond, in lieu of completing the above section of the Proposal Bid Bond Form. By providing an electronic bid bond ID code and signing below, the Principal is ensuring the identified electronic bid bond has been executed and the Principal and Surety are firmly bound unto the LPA under the conditions of the bid bond as shown above. (If PRINCIPAL is a joint venture of two or more contractors, an electronic bid bond ID code, company/Bidder name title and date must be affixed for each contractor in the venture.)

Electronic Bid Bond ID Code

--	--	--	--	--	--	--	--	--	--	--	--	--	--	--

Company/Bidder Name

--

Signature & Date

--

Title

--



Bureau of Construction
2300 South Dirksen Parkway/Room 322
Springfield, IL 62764

Instructions: Complete this form by either typing or using black ink. "Authorization to Bid" will not be issued unless both sides of this form are completed in detail. Use additional forms as needed to list all work.

Part I. Work Under Contract

List below all work you have under contract as either a prime contractor or a subcontractor. It is required to include all pending low bids not yet awarded or rejected. In a joint venture, list only that portion of the work which is the responsibility of your company. The uncompleted dollar value is to be based upon the most recent engineer's or owners estimate, and must include work subcontracted to others. If no work is contracted, show NONE.

	1	2	3	4	Awards Pending	Accumulated Totals
Contract Number						
Contract With						
Estimated Completion Date						
Total Contract Price						
Uncompleted Dollar Value if Firm is the Prime Contractor						
Uncompleted Dollar Value if Firm is the Subcontractor						
Total Value of All Work						

Part II. Awards Pending and Uncompleted Work to be done with your own forces.

List below the uncompleted dollar value of work for each contract and awards pending to be completed with your own forces. All work subcontracted to others will be listed on the reverse of this form. In a joint venture, list only that portion of the work to be done by your company. If no work is contracted, show NONE.

Earthwork						
Portland Cement Concrete Paving						
HMA Plant Mix						
HMA Paving						
Clean & Seal Cracks/Joints						
Aggregate Bases, Surfaces						
Highway, R.R., Waterway Struc.						
Drainage						
Electrical						
Cover and Seal Coats						
Concrete Construction						
Landscaping						
Fencing						
Guardrail						
Painting						
Signing						
Cold Milling, Planning, Rotomilling						
Demolition						
Pavement Markings (Paint)						
Other Construction (List)						
Totals						

Disclosure of this information is REQUIRED to accomplish the statutory purpose as outlined in the "Illinois Procurement Code." Failure to comply will result in non-issuance of an "Authorization To Bid." This form has been approved by the State Forms Management Center.

Part III. Work Subcontracted to Others.

For each contract described in Part I, list all the work you have subcontracted to others.

	1	2	3	4	Awards Pending
Subcontractor					
Type of Work					
Subcontract Price					
Amount Uncompleted					
Subcontractor					
Type of Work					
Subcontract Price					
Amount Uncompleted					
Subcontractor					
Type of Work					
Subcontract Price					
Amount Uncompleted					
Subcontractor					
Type of Work					
Subcontract Price					
Amount Uncompleted					
Subcontractor					
Type of Work					
Subcontract Price					
Amount Uncompleted					
Total Uncompleted					

Notary

I, being duly sworn, do hereby declare this affidavit is a true and correct statement relating to ALL uncompleted contracts of the undersigned for Federal, State, County, City and private work, including ALL subcontract work, ALL pending low bids not yet awarded or rejected and ALL estimated completion dates.

Officer or Director

Title

Signature

Date

Company

Address

City

State

Zip Code

Subscribed and sworn to before me

this _____ day of _____, _____

(Signature of Notary Public)

My commission expires _____

(Notary Seal)

Add pages for additional contracts



Local Public Agency

County

Section Number

Heritage Lake Subdivision Special Service Area

Tazewell

2026 SEAL COAT

Material Proposal Schedule of Prices

Group No.	Item(s)	Delivery	Unit	Quantity	Unit Price	Total
	P BIT MATLS C&S CT (CRS-2P)	Furnished & App	TON	97		
	COVER & SEAL COAT AGG (BLACK DIABASE CA-16)	Furnished & App	TON	704		
	TRAF CONT & PROT SPL	Furnished & App	L SUM	1		

The undersigned firm certifies that it has not been convicted of bribery or attempting to bribe an officer or employee of the State of Illinois, nor has the firm made an admission of guilt of such conduct which is a matter of record, nor has an official, agent, or employee of the firm committed bribery or attempted bribery on behalf of the firm and pursuant to the direction or authorization of a responsible official of the firm. The undersigned firm further certifies that it is not barred from contracting with any unit of State or local government as a result of a violation of State laws prohibiting bid-rigging or bid rotating.

Bidder Signature & Date

[Signature and Date box]

Address

City

State

Zip Code

[Address, City, State, Zip Code input fields]



Local Public Agency	County	Street Name/Road Name	Section Number
Heritage Lake Subdivision SSA	Tazewell	Various	2026 SEAL COAT

All contractors are required to complete the following certification

- For this contract proposal or for all bidding groups in this deliver and install proposal.
- For the following deliver and install bidding groups in this material proposal.

Illinois Department of Transportation policy, adopted in accordance with the provisions of the Illinois Highway Code, requires this contract to be awarded to the lowest responsive and responsible bidder. The award decision is subject to approval by the Department. In addition to all other responsibility factors, this contract or deliver and install proposal requires all bidders and all bidder's subcontractors to disclose participation in apprenticeship or training programs that are (1) approved by and registered with the United States Department of Labor's Bureau of Apprenticeship and Training, and (2) applicable to the work of the above indicated proposals or groups. Therefore, all bidders are required to complete the following certification:

1. Except as provided in paragraph 4 below, the undersigned bidder certifies that it is a participant, either as an individual or as part of a group program, in an approved apprenticeship or training program applicable to each type of work or craft that the bidder will perform with its own employees.
2. The undersigned bidder further certifies, for work to be performed by subcontract, that each of its subcontractors either (A) is, at the time of such bid, participating in an approved, applicable apprenticeship or training program; or (B) will, prior to commencement of performance of work pursuant to this contract, establish participation in an approved apprenticeship or training program applicable to the work of the subcontract.
3. The undersigned bidder, by inclusion in the list in the space below, certifies the official name of each program sponsor holding the Certificate of Registration for all of the types of work or crafts in which the bidder is a participant and that will be performed with the bidder's employees. Types of work or craft that will be subcontracted shall be included and listed as subcontract work. The list shall also indicate any type of work or craft job category for which there is no applicable apprenticeship or training program available.

4. Except for any work identified above, if any bidder or subcontractor shall perform all or part of the work of the contract or deliver and install proposal solely by individual owners, partners or members and not by employees to whom the payment of prevailing rates of wages would be required, check the following box, and identify the owner/operator workforces and positions of ownership.

The requirements of this certification and disclosure are a material part of the contract, and the contractor shall require this certification provision to be included in all approved subcontracts. The bidder is responsible for making a complete report and shall make certain that each type of work or craft job category that will be utilized on the project is accounted for and listed. The Department at any time before or afterward may require the production of a copy of each applicable Certificate of Registration issued by the United States Department of Labor evidencing such participation by the contractor and any or all of its subcontractors. In order to fulfill the participation requirement, it shall not be necessary that any applicable program sponsor be currently taking or that it will take applications for apprenticeship, training or employment during the performance of the work of this contract or deliver and install proposal.

Bidder	Signature & Date		
<div style="border: 1px solid black; height: 20px;"></div>	<div style="border: 1px solid black; height: 40px;"></div>		
Title			
<div style="border: 1px solid black; height: 20px;"></div>			
Address	City	State	Zip Code
<div style="border: 1px solid black; height: 20px;"></div>	<div style="border: 1px solid black; height: 20px;"></div>	<div style="border: 1px solid black; height: 20px;"></div>	<div style="border: 1px solid black; height: 20px;"></div>



Affidavit of Illinois Business Office

Local Public Agency	County	Street Name/Road Name	Section Number
Heritage Lake Subdivision SSA	Tazewell	Various	2026 SEAL COAT

I, _____ of _____, _____,
Name of Affiant City of Affiant State of Affiant

being first duly sworn upon oath, state as follows:

1. That I am the _____ of _____.
Officer or Position Bidder
2. That I have personal knowledge of the facts herein stated.
3. That, if selected under the proposal described above, _____, will maintain a business office in the
Bidder
 State of Illinois, which will be located in _____ County, Illinois.
County
4. That this business office will serve as the primary place of employment for any persons employed in the construction contemplated by this proposal.
5. That this Affidavit is given as a requirement of state law as provided in Section 30-22(8) of the Illinois Procurement Code.

Signature & Date

Print Name of Affiant

Notary Public

State of IL

County _____

Signed (or subscribed or attested) before me on _____ by
(date)

_____, authorized agent(s) of
(name/s of person/s)

Bidder

Notary Public Signature & Date

My commission expires _____

(SEAL)

INDEX
FOR
SUPPLEMENTAL SPECIFICATIONS
AND RECURRING SPECIAL PROVISIONS

Adopted January 1, 2026

This index contains a listing of SUPPLEMENTAL SPECIFICATIONS, frequently used RECURRING SPECIAL PROVISIONS, and LOCAL ROADS AND STREETS RECURRING SPECIAL PROVISIONS.

ERRATA Standard Specifications for Road and Bridge Construction
(Adopted 1-1-22) (Revised 1-1-26)

SUPPLEMENTAL SPECIFICATIONS

<u>Std. Spec. Sec.</u>		<u>Page No.</u>
109	Measurement and Payment	1
202	Earth and Rock Excavation	2
204	Borrow and Furnished Excavation	3
207	Porous Granular Embankment	4
211	Topsoil and Compost	5
214	Grading and Shaping Ditches	6
406	Hot-Mix Asphalt Binder and Surface Course	7
407	Hot-Mix Asphalt Pavement (Full-Depth)	9
420	Portland Cement Concrete Pavement	10
502	Excavation for Structures	11
504	Precast Concrete Structures	12
509	Metal Railings	13
522	Retaining Walls	14
540	Box Culverts	15
542	Pipe Culverts	35
550	Storm Sewers	44
586	Granular Backfill for Structures	51
601	Pipe Drains, Pipe Underdrains, and French Drains	52
630	Steel Plate Beam Guardrail	53
632	Guardrail and Cable Road Guard Removal	54
644	High Tension Cable Median Barrier	55
665	Woven Wire Fence	56
701	Work Zone Traffic Control and Protection	57
781	Raised Reflective Pavement Markers	59
782	Reflectors	60
801	Electrical Requirements	62
821	Roadway Luminaires	65
1003	Fine Aggregates	66
1004	Coarse Aggregates	67
1010	Finely Divided Minerals	69
1020	Portland Cement Concrete	70
1030	Hot-Mix Asphalt	73
1040	Drain Pipe, Tile, and Wall Drain	74
1042	Precast Concrete Products	75
1061	Waterproofing Membrane System	76
1067	Luminaire	77
1097	Reflectors	84
1102	Hot-Mix Asphalt Equipment	85



Local Public Agency	County	Section Number
Heritage Lake Subdivision Special Service Area	Tazewell	2026 SEAL COAT

Check this box for lettings prior to 01/01/2026

The Following Recurring Special Provisions Indicated By An "X" Are Applicable To This Contract And Are Included By Reference:

Recurring Special Provisions

<u>Check Sheet #</u>		<u>Page No.</u>
1	<input type="checkbox"/> Additional State Requirements for Federal-Aid Construction Contracts	87
2	<input type="checkbox"/> Subletting of Contracts (Federal-Aid Contracts)	90
3	<input type="checkbox"/> EEO	91
4	<input type="checkbox"/> Specific EEO Responsibilities Non Federal-Aid Contracts	101
5	<input type="checkbox"/> Required Provisions - State Contracts	106
6	<input type="checkbox"/> Asbestos Bearing Pad Removal	112
7	<input type="checkbox"/> Asbestos Waterproofing Membrane and Asbestos HMA Surface Removal	113
8	<input type="checkbox"/> Temporary Stream Crossings and In-Stream Work Pads	114
9	<input type="checkbox"/> Construction Layout Stakes	115
10	<input type="checkbox"/> Use of Geotextile Fabric for Railroad Crossing	118
11	<input type="checkbox"/> Subsealing of Concrete Pavements	120
12	<input type="checkbox"/> Hot-Mix Asphalt Surface Correction	124
13	<input type="checkbox"/> Pavement and Shoulder Resurfacing	126
14	<input type="checkbox"/> Patching with Hot-Mix Asphalt Overlay Removal	127
15	<input type="checkbox"/> Polymer Concrete	129
16	<input type="checkbox"/> Reserved	131
17	<input type="checkbox"/> Bicycle Racks	132
18	<input type="checkbox"/> Temporary Portable Bridge Traffic Signals	134
19	<input type="checkbox"/> Nighttime Inspection of Roadway Lighting	136
20	<input type="checkbox"/> English Substitution of Metric Bolts	137
21	<input type="checkbox"/> Calcium Chloride Accelerator for Portland Cement Concrete	138
22	<input type="checkbox"/> Quality Control of Concrete Mixtures at the Plant	139
23	<input type="checkbox"/> Quality Control/Quality Assurance of Concrete Mixtures	147
24	<input type="checkbox"/> Reserved	163
25	<input type="checkbox"/> Reserved	164
26	<input type="checkbox"/> Temporary Raised Pavement Markers	165
27	<input type="checkbox"/> Restoring Bridge Approach Pavements Using High-Density Foam	166
28	<input type="checkbox"/> Portland Cement Concrete Inlay or Overlay	169
29	<input type="checkbox"/> Portland Cement Concrete Partial Depth Hot-Mix Asphalt Patching	173
30	<input type="checkbox"/> Longitudinal Joint and Crack Patching	176
31	<input type="checkbox"/> Concrete Mix Design - Department Provided	178
32	<input type="checkbox"/> Station Numbers in Pavements or Overlays	179

Local Public Agency

County

Section Number

Heritage Lake Subdivision Special Service Area

Tazewell

2026 SEAL COAT

The Following Local Roads And Streets Recurring Special Provisions Indicated By An "X" Are Applicable To This Contract And Are Included By Reference:

Local Roads And Streets Recurring Special Provisions

<u>Check Sheet #</u>		<u>Page No.</u>
LRS 1	Reserved	181
LRS 2	<input type="checkbox"/> Furnished Excavation	182
LRS 3	<input checked="" type="checkbox"/> Work Zone Traffic Control Surveillance	183
LRS 4	<input checked="" type="checkbox"/> Flaggers in Work Zones	184
LRS 5	<input checked="" type="checkbox"/> Contract Claims	185
LRS 6	<input type="checkbox"/> Bidding Requirements and Conditions for Contract Proposals	186
LRS 7	<input checked="" type="checkbox"/> Bidding Requirements and Conditions for Material Proposals	192
LRS 8	Reserved	198
LRS 9	<input checked="" type="checkbox"/> Bituminous Surface Treatments	199
LRS 10	Reserved	203
LRS 11	<input checked="" type="checkbox"/> Employment Practices	204
LRS 12	<input checked="" type="checkbox"/> Wages of Employees on Public Works	206
LRS 13	<input checked="" type="checkbox"/> Selection of Labor	208
LRS 14	<input type="checkbox"/> Paving Brick and Concrete Paver Pavements and Sidewalks	209
LRS 15	<input checked="" type="checkbox"/> Partial Payments	212
LRS 16	<input type="checkbox"/> Protests on Local Lettings	213
LRS 17	<input checked="" type="checkbox"/> Substance Abuse Prevention Program	214
LRS 18	<input type="checkbox"/> Multigrade Cold Mix Asphalt	215
LRS 19	<input type="checkbox"/> Reflective Crack Control Treatment	216

TABLE OF CONTENTS

Page 1	Description of Work Proposal Guaranty Traffic Traffic Control Plan
Page 2	Traffic Control Plan (Cont'd.) Bituminous Surface Treatment, Class A
Page 3	Bituminous Surface Treatment, Class A (Cont'd.) Weight Limits Pre-Construction Meeting Liquidated Damages Time Schedule Wages of Employees on Public Works
Page 4-5	BDE Special Provisions Check Sheets
Page 6-29	BDE Special Provisions
Page 30-35	LR Special Provisions
Page 36	Project Location Map
Page 37	Quantity Sheet
Page 38	Highway Standard 701011-04
Page 39	Highway Standard 701306-04
Page 40-42	Highway Standard 701901-11



Local Public Agency	County	Section Number
Heritage Lake Subdivision Special Service Area	Tazewell	2026 Seal Coat

The following Special Provision supplement the "Standard Specifications for Road and Bridge Construction", adopted

January 1, 2022, the latest edition of the "Manual on Uniform Traffic Control Devices for Streets and Highways", and the "Manual of Test Procedures of Materials" in effect on the date of invitation of bids, and the Supplemental Specification and Recurring Special Provisions indicated on the Check Sheet included here in which apply to and govern the construction of the above named section, and in case of conflict with any parts, or parts of said Specifications, the said Special Provisions shall take precedence and shall govern.

DESCRIPTION OF WORK: The work of this section consists of the construction of a Bituminous Surface Treatment, Class A-1, Class A-2 and Class A-3 over existing bituminous surfaces.

TRAFFIC: The roads shall remain open for both local and through traffic.

TRAFFIC CONTROL PLAN: Traffic Control shall be in accordance with the applicable sections of the "Standard Specifications for Road and Bridge Construction", the applicable guidelines contained in the "Manual on Uniform Traffic Control Devices for Streets and Highways", these Special Provisions, and any special details and Highway Standards contained herein and in the plans.

Special attention is called to Articles 107.09, 107.14, 107.15 and Section 1106 of the "Standard Specifications for Road and Bridge Construction" and the Traffic Control Standards 701011-04, 701306-04 and 701901-11.

The Contractor shall post the construction routes with "LOOSE GRAVEL" and "SLOW" signs immediately prior to seal coat operations in accordance with applicable articles of Division 700 of the Standard Specifications. The signs shall be placed at the start of the work, near intersecting roadways and then at an average spacing of 0.50 miles. These signs may be removed as soon as the final sweeping operation has been completed or at the direction of the Engineer.

The presence of temporary traffic control drawings or standards in the proposal or contract, whether a pay item or not, does not relieve the Contractor of his obligation to the public. The Contractor shall provide, if conditions warrant by the Engineer, all protection deemed necessary beyond that shown in the proposal or Special Provisions.

The Contractor shall be responsible for all traffic control operations as follows:

1. The Contractor shall provide two flaggers and two pickup trucks, each equipped with a mounted yellow flashing light, a mounted "Road Closed" sign (R11-2), a mounted "Fresh Oil" sign (W21-2), and a "Flagger Traffic Control Sign" (Stop/Slow paddle). These flaggers shall be placed at the intersection immediately ahead of and behind the seal coat operation to control the traffic. Flaggers must hold the "Flagger Traffic Control Sign" (Stop/Slow paddle).
2. The Contractor must equip all of their oil distributors, chip spreaders and rollers with a mounted yellow flashing light.
3. The Contractor shall equip all of their rollers with a "Fresh Oil" sign (W21-2).
4. The Contractor shall place a "Road Closed Ahead" sign (W20-3) 750 feet prior to the intersection where the required pickup truck is controlling traffic if the pickup truck is not visible at that point to oncoming traffic.

Basis of payment: All Traffic Control shall be paid for at the contract-lump sum price for TRAFFIC CONTROL AND PROTECTION, (SPECIAL).

BITUMINOUS SURFACE TREATMENT, CLASS A: This work shall conform to the applicable portions of Check Sheet #LRS9, Special Provisions for Bituminous Surface Treatments, of the "Supplemental Specifications and Recurring Special Provisions", with the following exceptions and inclusions:

MATERIALS- Add the following:

The Bituminous Materials shall be CRS-2P where specified on the quantity sheet.

The Cover Coat Aggregate shall be Black Diabase CA-16 where specified on the quantity sheet.

The Seal Coat Aggregate shall be Black Diabase CA-16 where specified on the quantity sheet.

APPLICATION: Rates per Square Yard (Estimated)

When using CRS-2P for Bituminous Surface Treatment, Class A-1:

Polymerized Bituminous Materials (Seal Coat)	- 0.44 gallon
Seal Coat Aggregate (Black Diabase CA-16)	- 27 pounds

When using CRS-2P for Bituminous Surface Treatment, Class A-2:

Polymerized Bituminous Materials (Cover and Seal Coats)	- 0.44 gallon
Cover Coat Aggregate (Black Diabase Rock CA-16)	- 27 pounds
Seal Coat Aggregate (Black Diabase CA-16)	- 27 pounds

When using CRS-2P for Bituminous Surface Treatment, Class A-3:

Polymerized Bituminous Materials (Cover and Seal Coats)	- 0.44 gallon
Cover Coat Aggregate (Black Diabase Rock CA-16)	- 27 pounds
Seal Coat Aggregate (Black Diabase CA-16)	- 27 pounds

EQUIPMENT- Add the following:

(a) Rollers- Rollers shall include Two (2) Pneumatic-Tired Roller meeting the requirements of Article 1101.01 (a).

(b) Mechanical Sweeper- The mechanical sweeper shall be a vacuum type which collects the loose material that is swept from the surface meeting the requirements of Article 1101.03.

SEQUENCE OF WORK: Change item (a) as follows: Mechanical power sweeping of surface is required prior to Bituminous Surface Treatment, Class A-1, Class A-2 and Class A-3 applications. Where noted below, a pick-up sweeper shall be used under the following provisions:

1) Prior to placement of Bituminous Surface Treatment, Class A-1, Class A-2 and Class A-3 on all routes for this project. Please refer to project map and quantity sheet for locations.

Heritage Lake Subdivision Special Service Area

Tazewell

2026 Seal Coat

2) Ten days after placement of Bituminous Surface Treatment, Class A-1, Class A-2 and Class A-3 on all routes for this project. Please refer to project map and quantity sheet for locations.

3) Shall be included in the cost of the project.

SEAL COAT- Add the following:

Final sweeping shall not commence until 10 days after seal coat work is completed or at the direction of the Engineer.

Basis of Payment: This work will be paid for at the contract unit price per ton for POLYMERIZED BITUMINOUS MATERIALS (COVERS AND SEAL COATS) CRS-2P, **COVER AND SEAL COAT AGGREGATE (BLACK DIABASE CA-16)**.

WEIGHT LIMITS: Legal weight limits shall be observed on Heritage Lake Subdivision roads and the structures they contain at all times.

PRE-CONSTRUCTION MEETING: A pre-construction meeting for this Section is required.

LIQUIDATED DAMAGES: Liquidated damages shall be assessed in accordance with Article 108.10 of the "Standard Specifications for Road and Bridge Construction".

TIME SCHEDULE: The specified completion date for this project is August 15, 2026.

WAGES OF EMPLOYEES ON PUBLIC WORKS: Add the following to paragraph #1 of the Special Provision for Wages of Employees on Public Works, Check Sheet LRS#12: Prevailing wage rates may be obtained from the IDOL (Illinois Department of Labor) website at:

<https://labor.illinois.gov/laws-rules/conmed/rates.html>

BDE SPECIAL PROVISIONS
For the April 24 and June 12, 2026 Lettings

The following special provisions indicated by a “check mark” are applicable to this contract and will be included by the Project Coordination and Implementation Section of the Bureau of Design & Environment (BDE).

File Name	#		Special Provision Title	Effective	Revised	
	80099	1	<input type="checkbox"/>	Accessible Pedestrian Signals (APS)	April 1, 2003	Jan. 1, 2022
	80274	2	<input type="checkbox"/>	Aggregate Subgrade Improvement	April 1, 2012	April 1, 2022
	80192	3	<input type="checkbox"/>	Automated Flagger Assistance Devices	Jan. 1, 2008	April 1, 2023
	80173	4	<input type="checkbox"/>	Bituminous Materials Cost Adjustments	Nov. 2, 2006	Aug. 1, 2017
	80426	5	<input checked="" type="checkbox"/>	Bituminous Surface Treatment with Fog Seal	Jan. 1, 2020	April 1, 2026
	80475	6	<input type="checkbox"/>	Bridge Deck Concrete Overlays	Jan. 1, 2026	
*	80241	7	<input type="checkbox"/>	Bridge Demolition Debris	July 1, 2009	
*	50531	8	<input type="checkbox"/>	Building Removal	Sept. 1, 1990	Aug. 1, 2022
*	50261	9	<input type="checkbox"/>	Building Removal with Asbestos Abatement	Sept. 1, 1990	Aug. 1, 2022
	80460	10	<input checked="" type="checkbox"/>	Cement, Finely Divided Minerals, Admixtures, Concrete, and Mortar	Jan. 1, 2025	Jan. 1, 2026
	80384	11	<input checked="" type="checkbox"/>	Compensable Delay Costs	June 2, 2017	April 1, 2019
*	80198	12	<input type="checkbox"/>	Completion Date (via calendar days)	April 1, 2008	
*	80199	13	<input type="checkbox"/>	Completion Date (via calendar days) Plus Working Days	April 1, 2008	
	80461	14	<input type="checkbox"/>	Concrete Barrier	Jan. 1, 2025	
	80453	15	<input type="checkbox"/>	Concrete Sealer	Nov. 1, 2023	
	80261	16	<input type="checkbox"/>	Construction Air Quality – Diesel Retrofit	June 1, 2010	Jan. 1, 2025
	80476	17	<input type="checkbox"/>	Deck Slab Repair	Jan. 1, 2026	
*	80029	18	<input type="checkbox"/>	Disadvantaged Business Enterprise Participation	Sept. 1, 2000	Jan. 2, 2025
	80467	19	<input type="checkbox"/>	Erosion Control Blanket	Aug. 1, 2025	
	80229	20	<input type="checkbox"/>	Fuel Cost Adjustment	April 1, 2009	Aug. 1, 2017
	80452	21	<input type="checkbox"/>	Full Lane Sealant Waterproofing System	Nov. 1, 2023	
	80433	22	<input type="checkbox"/>	Green Preformed Thermoplastic Pavement Markings	Jan. 1, 2021	Jan. 1, 2022
	80471	23	<input type="checkbox"/>	Guardrail	Nov. 1, 2025	
	80472	24	<input type="checkbox"/>	High Friction Surface Treatment	Nov. 1, 2025	
	80456	25	<input type="checkbox"/>	Hot-Mix Asphalt	Jan. 1, 2024	April 1, 2026
	80446	26	<input type="checkbox"/>	Hot-Mix Asphalt - Longitudinal Joint Sealant	Nov. 1, 2022	Aug. 1, 2023
	80438	27	<input type="checkbox"/>	Illinois Works Apprenticeship Initiative – State Funded Contracts	June 2, 2021	April 2, 2024
	80483	28	<input type="checkbox"/>	Inlet Filters	April 1, 2026	
	80477	29	<input type="checkbox"/>	Longitudinal Tining	Jan. 1, 2026	
	80450	30	<input type="checkbox"/>	Mechanically Stabilized Earth Retaining Walls	Aug. 1, 2023	Aug. 1, 2025
	80478	31	<input type="checkbox"/>	Modified Longitudinal Construction Joint	Jan. 1, 2026	
	80464	32	<input type="checkbox"/>	Pavement Marking	April. 1, 2025	Nov. 1, 2025
	80468	33	<input type="checkbox"/>	Pavement Patching	Aug. 1, 2025	
	80441	34	<input type="checkbox"/>	Performance Graded Asphalt Binder	Jan. 1, 2023	April 1, 2026
	80459	35	<input type="checkbox"/>	Preformed Plastic Pavement Marking	June 2, 2024	
*	34261	36	<input type="checkbox"/>	Railroad Protective Liability Insurance	Dec. 1, 1986	Jan. 1, 2022
	80473	37	<input type="checkbox"/>	Raised Reflective Pavement Markers	Nov. 1, 2025	
	80455	38	<input checked="" type="checkbox"/>	Removal and Disposal of Regulated Substances	Jan. 1, 2024	April 1, 2026
	80474	39	<input type="checkbox"/>	Residential Driveway Temporary Signal	Nov. 1, 2025	
	80445	40	<input type="checkbox"/>	Seeding	Nov. 1, 2022	
	80457	41	<input type="checkbox"/>	Short Term and Temporary Pavement Markings	April 1, 2024	April 2, 2024
	80462	42	<input type="checkbox"/>	Sign Panels and Appurtenances	Jan. 1, 2025	Jan. 1, 2026
	80479	43	<input type="checkbox"/>	Sinusoidal Rumble Strips	Jan. 1, 2026	
	80469	44	<input type="checkbox"/>	Slope Wall	Aug. 1, 2025	
	80448	45	<input type="checkbox"/>	Source of Supply and Quality Requirements	Jan. 2, 2023	Jan. 1, 2026
	80340	46	<input type="checkbox"/>	Speed Display Trailer	April 2, 2014	Jan. 1, 2022
	80127	47	<input type="checkbox"/>	Steel Cost Adjustment	April 2, 2004	Nov. 1, 2025
	80480	48	<input type="checkbox"/>	Structural Repair of Concrete	Jan. 1, 2026	
	80397	49	<input type="checkbox"/>	Subcontractor and DBE Payment Reporting	April 2, 2018	
	80391	50	<input type="checkbox"/>	Subcontractor Mobilization Payments	Nov. 2, 2017	April 1, 2019
	80463	51	<input type="checkbox"/>	Submission of Bidders List Information	Jan. 2, 2025	Mar. 2, 2025

	80482	52	<input type="checkbox"/>	Submission of Payroll Records – Federal Aid Contract	April 1, 2026	
	80437	53	<input type="checkbox"/>	Submission of Payroll Records – State Contract	April 1, 2021	April 1, 2026
	80435	54	<input type="checkbox"/>	Surface Testing of Pavements – IRI	Jan. 1, 2021	Jan. 1, 2023
	80465	55	<input type="checkbox"/>	Surveying Services	April 1, 2025	
	80481	56	<input type="checkbox"/>	Temporary Concrete Barrier	Jan. 1, 2026	
	80466	57	<input type="checkbox"/>	Temporary Rumble Strips	April 1, 2025	
	80470	58	<input type="checkbox"/>	Traffic Signal Backplate	Aug. 1, 2025	
*	20338	59	<input type="checkbox"/>	Training Special Provisions	Oct. 15, 1975	Sept. 2, 2021
	80429	60	<input type="checkbox"/>	Ultra-Thin Bonded Wearing Course	April 1, 2020	Jan. 1, 2022
	80439	61	<input checked="" type="checkbox"/>	Vehicle and Equipment Warning Lights	Nov. 1, 2021	Nov. 1, 2022
	80458	62	<input type="checkbox"/>	Waterproofing Membrane System	Aug. 1, 2024	
	80302	63	<input type="checkbox"/>	Weekly DBE Trucking Reports	June 2, 2012	Jan. 2, 2025
	80454	64	<input type="checkbox"/>	Wood Sign Support	Nov. 1, 2023	
	80427	65	<input type="checkbox"/>	Work Zone Traffic Control Devices	Mar. 2, 2020	Jan. 1, 2026
*	80071	66	<input type="checkbox"/>	Working Days	Jan. 1, 2002	

Highlighted items indicate a new or revised special provision for the letting.

An * indicates the special provision requires additional information from the designer, which needs to be submitted separately. The Project Coordination and Implementation Section will then include the information in the applicable special provision.

The following special provisions are in the 2026 Supplemental Specifications and Recurring Special Provisions.

<u>File Name</u>	<u>Special Provision Title</u>	<u>New Location(s)</u>	<u>Effective</u>	<u>Revised</u>
80447	Grading and Shaping Ditches	Articles 214.03 & 214.04	Jan. 1, 2023	

CEMENT, FINELY DIVIDED MINERALS, ADMIXTURES, CONCRETE, AND MORTAR (BDE)

Effective: January 1, 2025

Revised: January 1, 2026

Revise the first paragraph of Article 285.05 of the Standard Specifications to read:

“285.05 Fabric Formed Concrete Revetment Mat. The grout shall consist of a mixture of cement, fine aggregate, and water so proportioned and mixed as to provide a pumpable slurry. Fly ash or ground granulated blast furnace (GGBF) slag, and concrete admixtures may be used at the option of the Contractor. The grout shall have an air content of not less than 6.0 percent nor more than 9.0 percent of the volume of the grout. The mix shall obtain a compressive strength of 2500 psi (17,000 kPa) at 28 days according to Article 1020.09.”

Revise Article 302.02 of the Standard Specifications to read:

“302.02 Materials. Materials shall be according to the following.

Item	Article/Section
(a) Cement	1001
(b) Water	1002
(c) Hydrated Lime	1012.01
(d) By-Product, Hydrated Lime	1012.02
(e) By-Product, Non-Hydrated Lime	1012.03
(f) Lime Slurry	1012.04
(g) Fly Ash	1010
(h) Soil for Soil Modification (Note 1)	1009.01
(i) Bituminous Materials (Note 2)	1032

Note 1. This soil requirement only applies when modifying with lime (slurry or dry).

Note 2. The bituminous materials used for curing shall be emulsified asphalt RS-2, CRS-2, HFE 90, or HFE 150; rapid curing liquid asphalt RC-70; or medium curing liquid asphalt MC-70 or MC-250.”

Revise Article 312.07(c) of the Standard Specifications to read:

“(c) Cement 1001”

Add Article 312.07(i) of the Standard Specifications to read:

“(i) Ground Granulated Blast Furnace (GGBF) Slag 1010”

Revise the first paragraph of Article 312.09 of the Standard Specifications to read:

“312.09 Proportioning and Mix Design. At least 60 days prior to start of placing CAM II, the Contractor shall submit samples of materials to be used in the work for proportioning and testing. The mixture shall contain a minimum of 200 lb (120 kg) of cement per cubic yard (cubic meter). Cement may be replaced with fly ash or ground granulated blast furnace (GGBF) slag according to Article 1020.05(c)(1) or 1020.05(c)(2), respectively, however the minimum cement content in the mixture shall be 170 lbs/cu yd (101 kg/cu m). Blends of coarse and fine aggregates will be permitted, provided the volume of fine aggregate does not exceed the volume of coarse aggregate. The Engineer will determine the proportions of materials for the mixture according to the “Portland Cement Concrete Level III Technician Course” manual. However, the Contractor may substitute their own mix design. Article 1020.05(a) shall apply, and a Level III PCC Technician shall develop the mix design.”

Revise Article 352.02 of the Standard Specifications to read:

“352.02 Materials. Materials shall be according to the following.

Item	Article/Section
(a) Cement (Note 1)	1001
(b) Soil for Soil-Cement Base Course	1009.03
(c) Water	1002
(d) Bituminous Materials (Note 2)	1032

Note 1. Bulk cement may be used for the traveling mixing plant method if the equipment for handling, weighing, and spreading the cement is approved by the Engineer.

Note 2. The bituminous materials used for curing shall be emulsified asphalt RS-2, CRS-2, HFE 90, or HFE 150; rapid curing liquid asphalt RC-70; or medium curing liquid asphalt MC-70 or MC-250.”

Revise Article 404.02 of the Standard Specifications to read:

“404.02 Materials. Materials shall be according to the following.

Item	Article/Section
(a) Cement	1001
(b) Water	1002
(c) Fine Aggregate	1003.08
(d) Bituminous Material (Tack Coat)	1032.06
(e) Emulsified Asphalts (Note 1) (Note 2)	1032.06
(f) Fiber Modified Joint Sealer	1050.05
(g) Additives (Note 3)	

Note 1. When used for slurry seal, the emulsified asphalt shall be CQS-1h according to Article 1032.06(b).

Note 2. When used for micro-surfacing, the emulsified asphalt shall be CQS-1hP according to Article 1032.06(e).

Note 3. Additives may be added to the emulsion mix or any of the component materials to provide the control of the quick-traffic properties. They shall be included as part of the mix design and be compatible with the other components of the mix.

Revise the last sentence of the fourth paragraph of Article 404.08 of the Standard Specifications to read:

“When approved by the Engineer, the sealant may be dusted with fine sand, cement, or mineral filler to prevent tracking.”

Revise Note 2 of Article 516.02 of the Standard Specifications to read:

“Note 2. The sand-cement grout mix shall be according to Section 1020 and shall be a 1:1 blend of sand and cement comprised of a Type I, IL, or II cement at 185 lb/cu yd (110 kg/cu m). The maximum water cement ratio shall be sufficient to provide a flowable mixture with a typical slump of 10 in. (250 mm).”

Revise Note 2 of Article 543.02 of the Standard Specifications to read:

“Note 2. The grout mixture shall be 6.50 hundredweight/cu yd (385 kg/cu m) of cement plus fine aggregate and water. Fly ash or ground granulated blast furnace (GGBF) slag may replace a maximum of 5.25 hundredweight/cu yd (310 kg/cu m) of the cement. The water/cement ratio, according to Article 1020.06, shall not exceed 0.60. An air-entraining admixture shall be used to produce an air content, according to Article 1020.08, of not less than 6.0 percent nor more than 9.0 percent of the volume of the grout. The Contractor shall have the option to use a water-reducing or high range water-reducing admixture.”

Revise Article 583.01 of the Standard Specifications to read:

“**583.01 Description.** This work shall consist of placing cement mortar along precast, prestressed concrete bridge deck beams as required for fairing out any unevenness between adjacent deck beams prior to placing of waterproofing membrane and surfacing.”

Revise Article 583.02(a) of the Standard Specifications to read:

“(a) Cement 1001”

Revise the first paragraph of Article 583.03 of the Standard Specifications to read:

“**583.03 General.** This work shall only be performed when the air temperature is 45 °F (7 °C) and rising. The mixture for cement mortar shall consist of three parts sand to one part cement by volume. The amount of water shall be no more than that necessary to produce a workable, plastic mortar.”

Revise Article 606.02(h) of the Standard Specifications to read:

“(h) Fibers (Note 1)1014”

Revise Note 1 in Article 606.02(h) of the Standard Specifications to read:

“Note 1. Fibers, when required, shall only be used in the concrete mixture for slipform applications.”

Revise the third paragraph in Article 606.10 of the Standard Specifications to read:

“Welded wire fabric shall be 6 x 6 in. (150 x 150 mm) mesh, #4 gauge (5.74 mm), 58 lb (26 kg) per 100 sq ft (9 sq m).”

Revise Article 1001.01(d) of the Standard Specifications to read:

“(d) Rapid Hardening Cement. Rapid hardening cement shall be according to the Bureau of Materials Policy Memorandum “Portland or Blended Cement Acceptance Procedure for Qualified and Non-Qualified Plants”, and ASTM C 1600, Type URH, Type VRH, or Type RH-CAC. It shall be used according to Article 1020.04 or when approved by the Engineer. The Contractor shall submit a report from the manufacturer or an independent lab that contains results for testing according to ASTM C 1600 which shows the cement meets the requirements of either Type URH, Type VRH, or Type RH-CAC. Test data shall be less than 1 year old from the date of submittal.

Revise Article 1001.01(e) of the Standard Specifications to read:

“(e) Other Cements. Other cements shall be according to the Bureau of Materials Policy Memorandum “Portland or Blended Cement Acceptance Procedure for Qualified and Non-Qualified Plants”, and ASTM C 1157 or ASTM C 1600, as applicable. Other cements shall be used according to Article 1020.04 or when approved by the Engineer. For cements according to ASTM C 1157, the Contractor shall submit a report from the manufacturer or an independent lab that contains results of tests which shows the cement meets the requirements Type GU, HE, MS, MH, or LH. For cements according to ASTM C 1600, the Contractor shall submit a report from the manufacturer or an independent lab that contains results of tests which shows the cement meets the requirements Type MRH or GRH. Test data shall be less than 1 year old from the date of submittal.”

Revise Article 1002.02 of the Standard Specifications to read:

“**1002.02 Quality.** Water used with cement in concrete or mortar and water used for curing concrete shall be clean, clear, and free from sugar. In addition, water shall be tested and evaluated for acceptance according to one of the following options.

OPTION 1.

(a) Acceptable limits for acidity and alkalinity when tested according to ITP T 26.

- (1) Acidity -- 0.1 Normal NaOH 2 ml max.*
 - (2) Alkalinity -- 0.1 Normal HCl..... 10 ml max.*
- *To neutralize 200 ml sample.

(b) Acceptable limits for solids when tested according to the following.

- (1) Organic (ITP T 26)..... 0.02% max.
- (2) Inorganic (ITP T 26)..... 0.30% max.
- (3) Sulfate (SO₄) (ASTM D 516-82) 0.05% max.
- (4) Chloride (ASTM D 512) 0.06% max.

(c) The following tests shall be performed on the water sample and on deionized water. The same cement and sand shall be used for both tests.

- (1) Unsoundness (ASTM C 151).
- (2) Initial and Final Set Time (ASTM C 266).
- (3) Strength (ASTM C 109).

The test results for the water sample shall not deviate from the test results for the deionized water, except as allowed by the precision in the test method.

OPTION 2. Water shall meet the requirements ASTM C 1602 Tables 1 and 2 as outlined in Sections 5.1, 5.2, and 5.4.”

Revise Note 2/ in Article 1003.01(b) of the Standard Specifications to read:

“2/ Applies only to sand. Sand exceeding the colorimetric test standard of 11 (Illinois Modified AASHTO T 21) will be checked for mortar making properties according to Illinois Modified ASTM C 87 and shall develop a compressive strength at the age of 14 days when using Type I, IL, or II cement of not less than 95 percent of the comparable standard.

Revise the second sentence of Article 1003.02(e)(1) of the Standard Specifications to read:

“The test will be performed with Type I, IL, or II portland cement having a total equivalent alkali content (Na₂O + 0.658K₂O) of 0.90 percent or greater.”

Revise the first sentence of the second paragraph of Article 1003.02(e)(3) of the Standard Specifications to read:

“The ASTM C 1293 test shall be performed with Type I, IL, or II portland cement having a total equivalent alkali content (Na₂O + 0.658K₂O) of 0.80 percent or greater.”

Revise the second sentence of Article 1004.02(g)(1) of the Standard Specifications to read:

“The test will be performed with Type I, IL, or II portland cement having a total equivalent alkali content ($\text{Na}_2\text{O} + 0.658\text{K}_2\text{O}$) of 0.90 percent or greater.”

Add the following Section to the Standard Specifications.

“SECTION 1014. FIBERS FOR CONCRETE

1014.01 General. Fibers used in concrete shall be Type II or Type III (polyolefin or carbon) according to ASTM C 1116. The testing required for Type II fibers or Type III polyolefin fibers shall be performed by an independent lab a minimum of once every five years, and the test results provided to the Department. Manufacturers of Type III carbon fibers shall provide materials certification documentation not more than 6 years old a minimum of once every 5 years to the Department. The Department will maintain a qualified product list. The method of inclusion of fibers into concrete mixtures shall be according to the manufacturer’s specifications.

At the discretion of the Engineer, the concrete mixture shall be evaluated in a field demonstration for fiber clumping, ease of placement, and ease of finishing. The field demonstration shall consist of a minimum 2 cu yd (1.5 cu m) trial batch placed in a 12 ft x 12 ft (3.6 m x 3.6 m) slab.

1014.02 Concrete Gutter, Curb, Median and Paved Ditch. Fibers shall be Type III. Fibers shall have a minimum length of 1/2 in. (13 mm) and a maximum length of 0.75 in. (19 mm). The maximum dosage rate in the concrete mixture shall not exceed 1.5 lb/cu yd (0.9 kg/cu m). The minimum dosage rate shall be per the manufacturer’s recommendation.

1014.03 Concrete Inlay or Overlay. Fibers shall be Type III. Fibers shall have a minimum length of 1.0 in. (25 mm), a maximum length of 2 1/2 in. (63 mm), and a maximum aspect ratio (length divided by the equivalent diameter of the fiber) of 150. The maximum dosage rate shall not exceed 5.0 lb/cu yd (3.0 kg/cu m). The minimum dosage rate shall be per the manufacturer’s recommendation.

1014.04 Bridge Deck Fly Ash, Ground Granulated Blast Furnace (GGBF) Slag, High Reactivity Metakaolin, or Microsilica (Silica Fume) Concrete Overlay. Fibers shall be Type III. The dosage rate shall be a minimum of 3.0 lb/cu yd (1.8 kg/cu m), unless a field demonstration according to Article 1014.01 indicates that a lower dosage rate is necessary. Based on the results of the field demonstration, the Department has the option to reduce the dosage rate of fibers, but the dosage will not be reduced to less than 2.0 lb / cu yd (1.2 kg/cu m).

1014.05 Bridge Deck Latex Concrete Overlay. Fibers shall be Type II or III. Fibers shall have a minimum length of 0.75 in. (19 mm), a maximum length of 1.75 in. (45 mm), and an aspect ratio (length divided by the equivalent diameter of the fiber) of between 70 and 100. The dosage rate shall be a minimum of 3.0 lb/cu yd (1.8 kg/cu m), unless a field demonstration according to Article 1014.01 indicates that a lower dosage rate is necessary. Based on the results of the field

demonstration, the Department has the option to reduce the dosage rate of fibers, but the dosage will not be reduced to less than 2.0 lb/cu yd (1.2 kg/cu m).”

Add the following Section to the Standard Specifications:

“SECTION 1015. HIGH PERFORMANCE SHOTCRETE

1015.01 Packaged Shotcrete With Aggregate. The packaged shotcrete with aggregate shall be a pre-blended dry combination of materials for the wet-mix shotcrete method according to ASTM C 1480, Type FA or CA, Grade FR, Class I. The fibers shall be Type III according to Article 1014.01. The cement and finely divided minerals in the mixture shall be a minimum 6.65 cwt/cu yd (395 kg/cu m), and the portland cement shall not be below 4.70 cwt/cu yd (279 kg/cu m). Microsilica is required in the mixture and shall be a minimum of 5 percent by weight (mass) of cementitious material, and a maximum of 10 percent. Strength requirements shall be according to ASTM C 1480 except that the strength at 28 days shall be at least 4000 psi (27,500 kPa). Strength testing shall be according to ASTM C 1140. The air content as shot shall be 4.0 – 8.0 percent when tested according to AASHTO T 152, and the coarse aggregate shall be a maximum size of 1/2 in. (12.5 mm).

The packaged shotcrete shall have a water soluble chloride ion content of less than 0.15% by weight of cementitious material when tested according to ASTM C 1218 or AASHTO T 260.

The testing according to ASTM C 1480, ASTM C 1140, AASHTO 152, and ASTM C 1218 or AASHTO T 260 shall be performed by an independent lab a minimum of once every 5 years, and the test results shall be provided to the Department. The Department will maintain a qualified product list. Batching and mixing shall be per the manufacturer’s recommendations.

1015.02 Packaged Shotcrete Without Aggregate. The packaged shotcrete that does not include pre-blended aggregate shall be according to Article 1015.01, except the added aggregate shall be according to Articles 1003.02 and 1004.02. The aggregate gradation shall be according to the manufacturer. The Department will maintain a qualified product list. Batching and mixing shall be per the manufacturer’s recommendations.”

Revise Section 1017 of the Standard Specifications to read:

“SECTION 1017. PACKAGED, DRY, COMBINED MATERIALS FOR MORTAR AND CONCRETE

1017.01 Mortar. The mortar shall be high-strength according to ASTM C 387 and shall have a minimum 80.0 percent relative dynamic modulus of elasticity when tested according to AASHTO T 161. For prestressed concrete applications, the mortar shall have a water-soluble chloride ion content of less than 0.06 percent by weight of cementitious material when tested according to ASTM C 1218 or AASHTO T 260; and for non-prestressed concrete applications, the water soluble chloride content shall be less than 0.15 percent by weight of cementitious material. The testing according to ASTM C 387, AASHTO T 161, and either ASTM C 1218 or AASHTO T 260 shall be performed by an independent lab a minimum of once every five years, and the test results

shall be provided to the Department. The Department will maintain a qualified product list. Mixing of the high-strength mortar shall be according to the manufacturer's specifications.

1017.02 Concrete. The materials, testing, and preparation of aggregate for the "high slump" packaged concrete mixture shall be according to ASTM C 387. The mixture shall be air entrained, the slump shall be 5-10 in. (125-250 mm), and the coarse aggregate shall be a maximum size of 1/2 in. (12.5 mm). Strength requirements shall be according to ASTM C 387 except that the strength at 28 days shall be at least 4000 psi (27,500 kPa). The "high slump" packaged concrete mixture shall have a water soluble chloride ion content of less than 0.15% by weight of cementitious material when tested according to ASTM C 1218 or AASHTO T 260. The testing according to ASTM C 387, and either ASTM C 1218 or AASHTO T 260 shall be performed by an independent lab a minimum of once every 5 years, and the test results shall be provided to the Department. The Department will maintain a qualified product list. Mixing shall be per the manufacturer's recommendations.

1017.02 Self-Consolidating Concrete. The materials, testing, and preparation of aggregate for the "self-consolidating concrete" packaged concrete mixture shall be according to ASTM C 387. The mixture shall be air entrained, it should be uniformly graded, and the coarse aggregate shall be a maximum size of 1/2 in. (12.5 mm). Strength requirements shall be according to ASTM C 387 except that the strength at 28 days shall be at least 4000 psi (27,500 Pa). Slump flow range shall be 22 in. (550 mm) minimum to 28 in. (700 mm) maximum when tested according to AASHTO T 347. The visual stability index shall be a maximum of 1 when tested according to AASHTO T 351. At the option of the manufacturer, either the J-Ring value shall be a maximum of 2 in. (50 mm) when tested according to AASHTO T 347 or the L-Box blocking ratio shall be a minimum of 80 percent when tested according AASHTO T 419. The hardened visual stability index shall be a maximum of 1 when tested according to AASHTO R 81.

The "self -consolidating concrete" packaged concrete mixture shall have a water soluble chloride ion content of less than 0.15 percent by weight of cementitious material when tested according to ASTM C 1218 or AASHTO T 260.

The testing according to ASTM C 387, AASHTO T 347, AASHTO T 351, AASHTO T 419, AASHTO R 81, ASTM C 1218 and AASHTO T 260 shall be performed by an independent lab a minimum of once every 5 years, and the test results shall be provided to the Department. The Department will maintain a qualified product list. Mixing shall be per the manufacturer's recommendations."

Revise Article 1018.01 of the Standard Specifications to read:

"1018.01 Requirements. The rapid hardening mortar or concrete shall be according to ASTM C 928 and shall have successfully completed and remain current with the AASHTO Product Eval and Audit Rapid Hardening Concrete Patching Materials (RHCP) testing program. R1, R2, or R3 concrete shall be air entrained, the slump shall be 5-10 in. (125-250 mm), and the coarse aggregate shall be a maximum size of 1/2 in. (12.5 mm). For prestressed concrete applications, the mortar or concrete shall have a water-soluble chloride ion content of less than 0.06 percent by weight of cementitious material when tested according to ASTM C 1218 or AASHTO T 260;

and for non-prestressed concrete applications, the water soluble chloride content shall be less than 0.15 percent by weight of cementitious material. The Department will maintain a qualified product list. Mixing of the mortar or concrete shall be according to the manufacturer's specifications..”

Revise Article 1019.02 of the Standard Specifications to read:

“**1019.02 Materials.** Materials shall be according to the following.

Item	Article/Section
(a) Cement	1001
(b) Water	1002
(c) Fine Aggregate for Controlled Low-Strength Material (CLSM)	1003.06
(d) Fly Ash	1010
(e) Ground Granulated Blast Furnace (GGBF) Slag.....	1010
(f) Admixtures (Note 1)	

Note 1. The air-entraining admixture may be in powder or liquid form. The air content produced by the admixture shall be 15-25 percent when incorporated into Mix 2 or an equivalent mixture as determined by the Department and tested according to AASHTO T 121 or AASHTO T 152. The testing according to AASHTO T 121 or AASHTO T 152 shall be performed by an independent lab a minimum of once every five years, and the test results shall be provided to the Department. The Department will maintain a qualified product list.”

Revise the third paragraph of Article 1019.04 of the Standard Specifications to read:

“The Engineer will instruct the Contractor to adjust the proportions of the mix design in the field as needed to meet the design criteria, provide adequate flowability, maintain proper solid suspension, or other criteria established by the Engineer.”

Revise Article 1019.05 of the Standard Specifications to read:

“**1019.05 Department Mix Design.** The Department mix design shall be Mix 1, 2, or 3 and shall be proportioned to yield approximately one cubic yard (cubic meter).

Mix 1	
Cement	50 lb (30 kg)
Fly Ash – Class C or F, and/or GGBF Slag	125 lb (74 kg)
Fine Aggregate – Saturated Surface Dry	2900 lb (1720 kg)
Water	50-65 gal (248-322 L)
Air Content	No air is entrained

Mix 2	
Cement	125 lb (74 kg)

Fine Aggregate – Saturated Surface Dry	2500 lb (1483 kg)
Water	35-50 gal (173-248 L)
Air Content	15-25 %

Mix 3	
Cement	40 lb (24 kg)
Fly Ash – Class C or F, and/or GGBF Slag	125 lb (74 kg)
Fine Aggregate – Saturated Surface Dry	2500 lb (1483 kg)
Water	35-50 gal (179-248 L)
Air Content	15-25 %

Revise Article 1020.04, Table 1, Note (8) of the Standard Specifications to read:

“(8) In addition to the Type III portland cement, 100 lb/cu yd of ground granulated blast-furnace slag and 50 lb/cu yd of microsilica (silica fume) shall be used. For an air temperature greater than 85 °F, the Type III portland cement may be replaced with Type I, IL, or II portland cement.”

Revise Article 1020.04, Table 1 (Metric), Note (8) of the Standard Specifications to read:

“(8) In addition to the Type III portland cement, 60 kg/cu m of ground granulated blast-furnace slag and 30 kg/cu m of microsilica (silica fume) shall be used. For an air temperature greater than 30 °C, the Type III portland cement may be replaced with Type I, IL, or II portland cement.”

Revise Note 9 of Table 1 of Article 1020.04 of the Standard Specifications to read:

“(9) The cement shall be a rapid hardening according to Article 1001.01(d). Minimum or maximum cement factor may be adjusted when approved by the Engineer.”

Revise the second paragraph of Article 1020.05(a) of the Standard Specifications to read:

“For a mix design using a portland-pozzolan cement, portland blast-furnace slag cement, portland-limestone cement, or replacing portland cement with finely divided minerals per Articles 1020.05(c) and 1020.05(d), the Contractor may submit a mix design with a minimum portland cement content less than 400 lbs/cu yd (237 kg/cu m), but not less than 375 lbs/cu yd (222 kg/cu m), if the mix design is shown to have a minimum relative dynamic modulus of elasticity of 80 percent determined according to AASHTO T 161. Testing shall be performed by an independent laboratory accredited by AASHTO re:source for Portland Cement Concrete.”

Revise the first sentence of the first paragraph of Article 1020.05(b) of the Standard Specifications to read:

“Corrosion inhibitors and concrete admixtures shall be according to the qualified product lists.”

Delete the fourth and fifth sentences of the second paragraph of Article 1020.05(b) of the Standard Specifications.

Revise Article 1020.05(b)(5) of the Standard Specifications to read:

“(5) For Class PP-4 concrete, a high range water-reducing admixture, retarder, and/or hydration stabilizer may be used in addition to the air-entraining admixture. The Contractor also has the option to use a water-reducing admixture with the high range water-reducing admixture. An accelerator shall not be used. A mobile portland cement concrete plant shall be used to produce the patching mixture.

For PP-5 concrete, a non-chloride accelerator, high range water-reducing admixture, retarder, hydration stabilizer, and/or air-entraining admixture may be used. The accelerator, high range water-reducing admixture, retarder, hydration stabilizer, and/or air-entraining admixture shall be per the Contractor’s recommendation and dosage. The qualified product list of concrete admixtures shall not apply. A mobile portland cement concrete plant shall be used to produce the patching mixture.”

Revise second paragraph of Article 1020.05(b)(10) of the Standard Specifications to read:

“When calcium nitrite is used, it shall be added at the rate of 4 gal/cu yd (20 L/cu m) and shall be added to the mix immediately after all compatible admixtures have been introduced to the batch. Other corrosion inhibitors shall be added per the manufacturer’s specifications.”

Delete the third paragraph of Article 1020.05(b)(10) of the Standard Specifications.

Revise Article 1020.15(b)(1)c. of the Standard Specifications to read:

“c. The minimum portland cement content in the mixture shall be 375 lbs/cu yd (222 kg/cu m). When the total of organic processing additions, inorganic processing additions, and limestone addition exceed 5.0 percent in the cement, the minimum portland cement content in the mixture shall be 400 lbs/cu yd (237 kg/cu m). For a drilled shaft, foundation, footing, or substructure, the minimum portland cement may be reduced to as low as 330 lbs/cu yd (196 kg/cu m) if the concrete has adequate freeze/thaw durability. The Contractor shall provide freeze/thaw test results according to AASHTO T 161, and the relative dynamic modulus of elasticity of the mix design shall be a minimum of 80 percent. Testing shall be performed by an independent laboratory accredited by AASHTO re:source for Portland Cement Concrete. Freeze/thaw testing will not be required for concrete that will not be exposed to freezing and thawing conditions as determined by the Engineer.”

Revise Article 1021.01 of the Standard Specifications to read:

“1021.01 General. Admixtures shall be furnished in liquid or powder form ready for use. The admixtures shall be delivered in the manufacturer's original containers, bulk tank trucks or such containers or tanks as are acceptable to the Engineer. Delivery shall be accompanied by a ticket which clearly identifies the manufacturer, the date of manufacture, and trade name of the material. Containers shall be readily identifiable as to manufacturer, the date of manufacture, and trade name of the material they contain.

Concrete admixtures shall be on one of the Department's qualified product lists. Unless otherwise noted, admixtures shall have successfully completed and remain current with the AASHTO Product Eval and Audit Concrete Admixture (CADD) testing program. For admixture submittals to the Department; the product brand name, manufacturer name, admixture type or types, an electronic link to the product's technical data sheet, and the NTPEP testing number which contains an electronic link to all test data shall be provided. In addition, a letter shall be submitted certifying that no changes have been made in the formulation of the material since the most current round of tests conducted by AASHTO Product Eval and Audit. After 28 days of testing by AASHTO Product Eval and Audit, air-entraining admixtures may be provisionally approved and used on Departmental projects. For all other admixtures, unless otherwise noted, the time period after which provisionally approved status may be earned is 6 months.

The manufacturer shall include the following in the submittal to the AASHTO Product Eval and Audit CADD testing program: the manufacturing range for specific gravity, the midpoint and manufacturing range for residue by oven drying, and manufacturing range of pH. The submittal shall also include an infrared spectrophotometer trace no more than five years old.

For air-entraining admixtures according to Article 1021.02, the specific gravity allowable manufacturing range established by the manufacturer shall be according to AASHTO M 194. For residue by oven drying and pH, the allowable manufacturing range and test methods shall be according to AASHTO M 194.

For admixtures according to Articles 1021.03, 1021.04, 1021.05, 1021.06, 1021.07, and 1021.08, the pH allowable manufacturing range established by the manufacturer shall be according to ASTM E 70. For specific gravity and residue by oven drying, the allowable manufacturing range and test methods shall be according to AASHTO M 194.

All admixtures, except chloride-based accelerators, shall contain a maximum of 0.3 percent chloride by weight (mass) as determined by an appropriate test method. To verify the test result, the Department will use Illinois Modified AASHTO T 260, Procedure A, Method 1.

Prior to final approval of an admixture, the Engineer reserves the right to request a sample for testing. The test and reference concrete mixtures tested by the Engineer will contain a cement content of 5.65 cwt/cu yd (335 kg/cu m). For freeze-thaw testing, the Department will perform the test according to Illinois Modified AASHTO T 161. The flexural strength test will be performed according to AASHTO T 177. If the Engineer decides to test the admixture, the manufacturer shall submit AASHTO T 197 water content and set time test results on the standard cement used by the Department. The manufacturer may select their lab or an independent lab to perform this testing. The laboratory is not required to be accredited by AASHTO.

Random field samples may be taken by the Department to verify an admixture meets specification. A split sample will be provided to the manufacturer if requested. Admixtures that do not meet specification requirements or an allowable manufacturing range established by the manufacturer shall be replaced with new material.”

Revise Article 1021.03 of the Standard Specifications to read:

“**1021.03 Retarding and Water-Reducing Admixtures.** The admixture shall be according to the following.

- (a) Retarding admixtures shall be according to AASHTO M 194, Type B (retarding) or Type D (water-reducing and retarding).
- (b) Water-reducing admixtures shall be according to AASHTO M 194, Type A.
- (c) High range water-reducing admixtures shall be according to AASHTO M 194, Type F (high range water-reducing) or Type G (high range water-reducing and retarding).”

Revise Article 1021.05 of the Standard Specifications to read:

“**1021.05 Self-Consolidating Admixtures.** Self-consolidating admixture systems shall consist of either a high range water-reducing admixture only or a high range water-reducing admixture combined with a separate viscosity modifying admixture. The one or two component admixture system shall be capable of producing a concrete that can flow around reinforcement and consolidate under its own weight without additional effort and without segregation.

High range water-reducing admixtures shall be according to AASHTO M 194, Type F.

Viscosity modifying admixtures shall be according to AASHTO M 194, Type S (specific performance).”

Revise Article 1021.06 of the Standard Specifications to read:

“**1021.06 Rheology-Controlling Admixture.** Rheology-controlling admixtures shall be capable of producing a concrete mixture with a lower yield stress that will consolidate easier for slipform applications used by the Contractor. Rheology-controlling admixtures shall be according to AASHTO M 194, Type S (specific performance).”

Revise Article 1021.07 of the Standard Specifications to read:

“**1021.07 Corrosion Inhibitor.** The corrosion inhibitor shall be according to one of the following.

- (a) Calcium Nitrite. Corrosion inhibitors shall contain a minimum 30 percent calcium nitrite by weight (mass) of solution and shall comply with either the requirements of AASHTO

M 194, Type C (accelerating) or the requirements of ASTM C 1582. The corrosion inhibiting performance requirements of ASTM C 1582 shall not apply.

(b) Other Materials. The corrosion inhibitor shall be according to ASTM C 1582.

For submittals requiring testing according to ASTM M 194, Type C (accelerating), the admixture shall meet the requirements of the AASHTO Product Eval and Audit CADD testing program according to Article 1021.01.

For submittals requiring testing according to ASTM C 1582, a report prepared by an independent laboratory accredited by AASHTO re:source for portland cement concrete shall be provided. The report shall show the results of physical tests conducted no more than five years prior to the time of submittal, according to applicable specifications. However, ASTM G 109 test information specified in ASTM C 1582 is not required to be from an independent accredited lab. All other information in ASTM C 1582 shall be from an independent accredited lab. Test data and other information required to be submitted to AASHTO Product Eval and Audit according to Article 1021.01, shall instead be submitted directly to the Department.”

Add Article 1021.08 of the Standard Specifications as follows:

“1021.08 Other Specific Performance Admixtures. Other specific performance admixtures shall, at a minimum, be according to AASHTO M 194, Type S (specific performance). The Department also reserves the right to require other testing, as determined by the Engineer, to show evidence of specific performance characteristics.

Initial testing according to AASHTO M 194 may be conducted under the AASHTO Product Eval and Audit CADD testing program according to Article 1021.01, or by an independent laboratory accredited by AASHTO re:source for Portland Cement Concrete. In either case, test data and other information required to be submitted to AASHTO Product Eval and Audit according to Article 1021.01, shall also be submitted directly to the Department. The independent accredited lab report shall show the results of physical tests conducted no more than five years prior to the time of submittal, according to applicable specifications.”

Add Article 1021.09 of the Standard Specifications as follows:

“1021.09 Latex Admixtures. The latex admixture shall be a uniform, homogeneous, non-toxic, film-forming, polymeric emulsion in water to which all stabilizers have been added at the point of manufacture. The latex admixture shall not contain any chlorides and shall contain 46-49 percent solids.

In lieu of meeting the requirements of Article 1021.01, the Contractor shall submit a manufacturer's certification that the latex emulsion meets the requirements of FHWA Research Report RD-78-35, Chapter VI. The certificate shall include the date of manufacture of the latex admixture, batch or lot number, quantity represented, manufacturer's name, and the location of the manufacturing plant. The latex emulsion shall be sampled and tested in accordance with RD-78-35, Chapter VII, Certification Program.

The latex admixture shall be packaged and stored in containers and storage facilities which will protect the material from freezing and from temperatures above 85°F (30°C). Additionally, the material shall not be stored in direct sunlight and shall be shaded when stored outside of buildings during moderate temperatures.”

Revise Article 1024.01 of the Standard Specifications to read:

“1024.01 Requirements for Grout. The grout shall be proportioned by dry volume, thoroughly mixed, and shall have a minimum temperature of 50 °F (10 °C). Water shall not exceed the minimum needed for placement and finishing.

Materials for the grout shall be according to the following.

Item	Article/Section
(a) Cement	1001
(b) Water	1002
(c) Fine Aggregate	1003.02
(d) Fly Ash	1010
(e) Ground Granulated Blast Furnace (GGBF) Slag.....	1010
(f) Concrete Admixtures	1021”

Revise Note 1 of Article 1024.02 of the Standard Specifications to read:

“Note 1. Nonshrink grout shall be according to ASTM C 1107.

For prestressed concrete applications, the nonshrink grout shall have a water soluble chloride ion content of less than 0.06 percent by weight of cementitious material when tested according to ASTM C 1218 or AASHTO T 260; and for non-prestressed concrete applications, the water soluble chloride ion content shall be less than 0.15 percent by weight of cementitious material. The testing according to ASTM 1107, and either ASTM C 1218 or AASHTO T 260 shall be performed by an independent lab a minimum of once every five years, and the test results shall be provided to the Department. The Department will maintain a qualified product list. Mixing of the nonshrink grout shall be according to the manufacturer’s specifications.”

Revise Article 1029.02 of the Standard Specifications to read:

“1029.02 Materials. Materials shall be according to the following.

Item	Article/Section
(a) Cement.....	1001
(b) Fly Ash	1010
(c) Ground Granulated Blast Furnace (GGBF) Slag	1010
(d) Water.....	1002
(e) Fine Aggregate.....	1003
(f) Concrete Admixtures	1021

(g) Foaming Agent (Note 1)

Note 1. The manufacturer shall submit infrared spectrophotometer trace and test results indicating the foaming agent meets the requirements of ASTM C 869 in order to be on the Department's qualified product list. Submitted data/results shall not be more than five years old."

Revise the second paragraph of Article 1103.03(a)(4) the Standard Specifications to read:

"The dispenser system shall provide a visual indication that the liquid admixture is actually entering the batch, such as via a transparent or translucent section of tubing or by independent check with an integrated secondary metering device. If approved by the Engineer, an alternate indicator may be used for admixtures dosed at rates of 25 oz/cwt (1630 mL/100 kg) or greater, such as accelerating admixtures, corrosion inhibitors, and viscosity modifying admixtures."

Revise Article 1103.04 of the Standard Specifications to read:

"1103.04 Mobile Portland Cement Concrete Plants. The mobile concrete plant shall be according to AASHTO M 241 and the Bureau of Materials Policy Memorandum "Approval of Volumetric Mobile Mixers for Concrete". The mixer shall be capable of carrying sufficient unmixed materials to produce not less than 6 cu yd (4.6 cu m) of concrete."

Revise the first two sections of Check Sheet #11 "Subsealing of Concrete Pavements" of the Recurring Special Provisions to read:

"Description. This work shall consist of filling voids beneath rigid and composite pavements with cement grout.

Materials. Materials shall be according to the following Articles/Sections of the Standard Specifications:

Item	Article/Section
(a) Cement	1001
(b) Water	1002
(c) Fly Ash	1010
(d) Ground Granulated Blast Furnace (GGBF) Slag.....	1010
(e) Admixtures	1021
(f) Packaged Rapid Hardening Mortar or Concrete	1018"

Revise the Materials section of Check Sheet #28 "Portland Cement Concrete Inlay or Overlay" of the Recurring Special Provisions to read:

"Materials. Materials shall be according to the following Articles/Sections of the Standard Specifications.

Item	Article/Section
(a) Portland Cement Concrete (Note 1)	1020
(b) Fibers for Concrete.....	1014
(c) Protective Coat.....	1023.01

Note 1. Class PV concrete shall be used, except the cement factor for central mixed concrete shall be 6.05 cwt/cu yd (360 kg/cu m). A cement factor reduction according to Article 1020.05(b)(8) of the Standard Specifications will be permitted. CA 5 shall not be used and CA 7 may only be used for overlays that are a minimum of 4.5 in. (113 mm) thick. The Class PV concrete shall have a minimum flexural strength of 550 psi (3800 kPa) or a minimum compressive strength of 3000 psi (20,700 kPa) at 14 days.”

80460

COMPENSABLE DELAY COSTS (BDE)

Effective: June 2, 2017

Revised: April 1, 2019

Revise Article 107.40(b) of the Standard Specifications to read:

“(b) Compensation. Compensation will not be allowed for delays, inconveniences, or damages sustained by the Contractor from conflicts with facilities not meeting the above definition; or if a conflict with a utility in an unanticipated location does not cause a shutdown of the work or a documentable reduction in the rate of progress exceeding the limits set herein. The provisions of Article 104.03 notwithstanding, compensation for delays caused by a utility in an unanticipated location will be paid according to the provisions of this Article governing minor and major delays or reduced rate of production which are defined as follows.

- (1) Minor Delay. A minor delay occurs when the work in conflict with the utility in an unanticipated location is completely stopped for more than two hours, but not to exceed two weeks.
- (2) Major Delay. A major delay occurs when the work in conflict with the utility in an unanticipated location is completely stopped for more than two weeks.
- (3) Reduced Rate of Production Delay. A reduced rate of production delay occurs when the rate of production on the work in conflict with the utility in an unanticipated location decreases by more than 25 percent and lasts longer than seven calendar days.”

Revise Article 107.40(c) of the Standard Specifications to read:

“(c) Payment. Payment for Minor, Major, and Reduced Rate of Production Delays will be made as follows.

- (1) Minor Delay. Labor idled which cannot be used on other work will be paid for according to Article 109.04(b)(1) and (2) for the time between start of the delay and the minimum remaining hours in the work shift required by the prevailing practice in the area.

Equipment idled which cannot be used on other work, and which is authorized to standby on the project site by the Engineer, will be paid for according to Article 109.04(b)(4).

- (2) Major Delay. Labor will be the same as for a minor delay.

Equipment will be the same as for a minor delay, except Contractor-owned equipment will be limited to two weeks plus the cost of move-out to either the

Contractor's yard or another job and the cost to re-mobilize, whichever is less. Rental equipment may be paid for longer than two weeks provided the Contractor presents adequate support to the Department (including lease agreement) to show retaining equipment on the job is the most economical course to follow and in the public interest.

- (3) Reduced Rate of Production Delay. The Contractor will be compensated for the reduced productivity for labor and equipment time in excess of the 25 percent threshold for that portion of the delay in excess of seven calendar days. Determination of compensation will be in accordance with Article 104.02, except labor and material additives will not be permitted.

Payment for escalated material costs, escalated labor costs, extended project overhead, and extended traffic control will be determined according to Article 109.13.”

Revise Article 108.04(b) of the Standard Specifications to read:

“(b) No working day will be charged under the following conditions.

- (1) When adverse weather prevents work on the controlling item.
- (2) When job conditions due to recent weather prevent work on the controlling item.
- (3) When conduct or lack of conduct by the Department or its consultants, representatives, officers, agents, or employees; delay by the Department in making the site available; or delay in furnishing any items required to be furnished to the Contractor by the Department prevents work on the controlling item.
- (4) When delays caused by utility or railroad adjustments prevent work on the controlling item.
- (5) When strikes, lock-outs, extraordinary delays in transportation, or inability to procure critical materials prevent work on the controlling item, as long as these delays are not due to any fault of the Contractor.
- (6) When any condition over which the Contractor has no control prevents work on the controlling item.”

Revise Article 109.09(f) of the Standard Specifications to read:

“(f) Basis of Payment. After resolution of a claim in favor of the Contractor, any adjustment in time required for the work will be made according to Section 108. Any adjustment in the costs to be paid will be made for direct labor, direct materials, direct equipment, direct jobsite overhead, direct offsite overhead, and other direct costs allowed by the resolution. Adjustments in costs will not be made for interest charges, loss of anticipated profit, undocumented loss of efficiency, home office overhead and unabsorbed overhead

other than as allowed by Article 109.13, lost opportunity, preparation of claim expenses and other consequential indirect costs regardless of method of calculation.

The above Basis of Payment is an essential element of the contract and the claim cost recovery of the Contractor shall be so limited.”

Add the following to Section 109 of the Standard Specifications.

“109.13 Payment for Contract Delay. Compensation for escalated material costs, escalated labor costs, extended project overhead, and extended traffic control will be allowed when such costs result from a delay meeting the criteria in the following table.

Contract Type	Cause of Delay	Length of Delay
Working Days	Article 108.04(b)(3) or Article 108.04(b)(4)	No working days have been charged for two consecutive weeks.
Completion Date	Article 108.08(b)(1) or Article 108.08(b)(7)	The Contractor has been granted a minimum two week extension of contract time, according to Article 108.08.

Payment for each of the various costs will be according to the following.

- (a) Escalated Material and/or Labor Costs. When the delay causes work, which would have otherwise been completed, to be done after material and/or labor costs have increased, such increases will be paid. Payment for escalated material costs will be limited to the increased costs substantiated by documentation furnished by the Contractor. Payment for escalated labor costs will be limited to those items in Article 109.04(b)(1) and (2), except the 35 percent and 10 percent additives will not be permitted.
- (b) Extended Project Overhead. For the duration of the delay, payment for extended project overhead will be paid as follows.
 - (1) Direct Jobsite and Offsite Overhead. Payment for documented direct jobsite overhead and documented direct offsite overhead, including onsite supervisory and administrative personnel, will be allowed according to the following table.

Original Contract Amount	Supervisory and Administrative Personnel
Up to \$5,000,000	One Project Superintendent
Over \$ 5,000,000 - up to \$25,000,000	One Project Manager, One Project Superintendent or Engineer, and One Clerk
Over \$25,000,000 - up to \$50,000,000	One Project Manager, One Project Superintendent, One Engineer, and

	One Clerk
Over \$50,000,000	One Project Manager, Two Project Superintendents, One Engineer, and One Clerk

(2) Home Office and Unabsorbed Overhead. Payment for home office and unabsorbed overhead will be calculated as 8 percent of the total delay cost.

(c) Extended Traffic Control. Traffic control required for an extended period of time due to the delay will be paid for according to Article 109.04.

When an extended traffic control adjustment is paid under this provision, an adjusted unit price as provided for in Article 701.20(a) for increase or decrease in the value of work by more than ten percent will not be paid.

Upon payment for a contract delay under this provision, the Contractor shall assign subrogation rights to the Department for the Department's efforts of recovery from any other party for monies paid by the Department as a result of any claim under this provision. The Contractor shall fully cooperate with the Department in its efforts to recover from another party any money paid to the Contractor for delay damages under this provision."

80384

REMOVAL AND DISPOSAL OF REGULATED SUBSTANCES (BDE)

Effective: January 1, 2024

Revised: April 1, 2026

Revise the first paragraph of Article 669.04 of the Standard Specifications to read:

“669.04 Regulated Substances Monitoring. Regulated substances monitoring includes environmental observation and field screening during regulated substances management activities. The excavated soil and groundwater within the work areas shall be managed as either uncontaminated soil, hazardous waste, special waste, or non-special waste.

As part of the regulated substances monitoring, the monitoring personnel shall perform and document the applicable duties listed on form BDE 2732 “Regulated Substances Monitoring Daily Record (RSM DR)”.

Revise the first two sentences of the nineteenth paragraph of Article 669.05 of the Standard Specifications to read:

“The Contractor shall coordinate waste disposal approvals with the disposal facility and provide the specific analytical testing requirements of that facility. The Contractor shall make all arrangements for collection, transportation, and analysis of landfill acceptance testing.”

Revise the last paragraph of Article 669.05 of the Standard Specifications to read:

“The Contractor shall select a permitted landfill facility or CCDD/USFO facility meeting the requirements of 35 Ill. Admin. Code Parts 810-814 or Part 1100, respectively. The Department will review and approve or reject the facility proposed by the Contractor based upon information provided in BDE 2730. The Contractor shall verify whether the selected facility is compliant with those applicable standards as mandated by their permit and whether the facility is presently, has previously been, or has never been, on the United States Environmental Protection Agency (U.S. EPA) National Priorities List or the Resource Conservation and Recovery Act (RCRA) List of Violating Facilities. The use of a Contractor selected facility shall in no manner delay the construction schedule or alter the Contractor's responsibilities as set forth.”

Revise the first paragraph of Article 669.07 of the Standard Specifications to read:

“669.07 Temporary Staging. Soil classified according to Articles 669.05(a)(2), (b)(1), or (c) may be temporarily staged at the Contractor's option. All other soil classified according to Articles 669.05(a)(1), (a)(3), (a)(4), (a)(5), (a)(6), or (b)(2) shall be managed and disposed of without temporary staging to the greatest extent practicable. If circumstances beyond the Contractor's control require temporary staging of these latter materials, the Contractor shall request approval from the Engineer in writing.

Topsoil for re-use as final cover which has been field screened and found not to exhibit PID readings over daily background readings as documented on the BDE 2732, visual staining or

odors, and is classified according to Articles 669.05(a)(2), (a)(3), (a)(4), (b)(1), or (c) may be temporarily staged at the Contractor's option."

Add the following paragraph after the fourth paragraph of Article 669.10 of the Standard Specifications.

"Regulated substances monitoring will be measured for payment per calendar day, where 4 or more hours of monitoring activities is defined as 1.0 calendar day and less than 4 hours of monitoring activities is defined as 0.5 calendar day."

Revise the second paragraph of Article 669.11 of the Standard Specification to read:

"Regulated substances monitoring, including completion of form BDE 2732 for each day of work, will be paid for at the contract unit price per calendar day for REGULATED SUBSTANCES MONITORING. In no case will more than 1.0 calendar day be paid on a given calendar day."

Add the following paragraph after the sixth paragraph of Article 669.11 of the Standard Specifications.

"The sampling and testing of effluent water derived from dewatering discharges for priority pollutants volatile organic compounds (VOCs), priority pollutants semi-volatile organic compounds (SVOCs), or priority pollutants metals, will be paid for at the contract unit price per each for VOCS GROUNDWATER ANALYSIS using EPA Method 8260B, SVOCs GROUNDWATER ANALYSIS using EPA Method 8270C, or RCRA METALS GROUNDWATER ANALYSIS using EPA Methods 6010B and 7471A. This price shall include transporting the sample from the job site to the laboratory."

Revise the first sentence of the eight paragraph of Article 669.11 of the Standard Specifications to read:

"Payment for temporary staging of soil classified according to Articles 669.05(a)(1), (a)(3), (a)(4), (a)(5), (a)(6), or (b)(2) to be managed and disposed of, if required and approved by the Engineer, will be paid according to Article 109.04."

80455

VEHICLE AND EQUIPMENT WARNING LIGHTS (BDE)

Effective: November 1, 2021

Revised: November 1, 2022

Add the following paragraph after the first paragraph of Article 701.08 of the Standard Specifications:

“The Contractor shall equip all vehicles and equipment with high-intensity oscillating, rotating, or flashing, amber or amber-and-white, warning lights which are visible from all directions. In accordance with 625 ILCS 5/12-215, the lights may only be in operation while the vehicle or equipment is engaged in construction operations.”

80439

State of Illinois
Department of Transportation
Bureau of Local Roads and Streets

SPECIAL PROVISION
FOR
INSURANCE

Effective: February 1, 2007
Revised: August 1, 2007

All references to Sections or Articles in this specification shall be construed to mean specific Section or Article of the Standard Specifications for Road and Bridge Construction, adopted by the Department of Transportation.

The Contractor shall name the following entities as additional insured under the Contractor's general liability insurance policy in accordance with Article 107.27:

The entities listed above and their officers, employees, and agents shall be indemnified and held harmless in accordance with Article 107.26.

State of Illinois
Department of Transportation
Bureau of Local Roads and Streets

SPECIAL PROVISION
FOR
EQUIPMENT RENTAL RATES

Effective: January 1, 2012

All references to Sections or Articles in this specification shall be construed to mean a specific Section or Article of the Standard Specifications for Road and Bridge Construction, adopted by the Department of Transportation.

Replace Article 109.04(b)(4) with the following:

- "(4) Equipment. For any machinery or special equipment (other than small tools) the use of which has been authorized by the Engineer, the Contractor will be paid according to the latest revision of "SCHEDULE OF AVERAGE ANNUAL EQUIPMENT OWNERSHIP EXPENSE" and latest index factor as issued by the Illinois Department of Transportation. The equipment should be of a type and size reasonably required to complete the extra work."

State of Illinois
Department of Transportation
Bureau of Local Roads and Streets

SPECIAL PROVISION
FOR
COARSE AGGREGATE FOR BITUMINOUS SURFACE TREATMENT

Effective: January 1, 2002
Revised: January 1, 2007

All references to Sections or Articles in this special provision shall be construed to mean specific Section or Article of the Standard Specifications for Road and Bridge Construction, adopted by the Department of Transportation.

This work shall be performed according to Section 403 and the following:

1004.01 Materials. Add the following to the gradation tables in subparagraph (c) of Article 1004.01:

Coarse Aggregate Gradations					
Sieve Size					
Percent Passing					
Grad No.	12.5 mm ½ in.	9.5 mm 3/8 in.	4.75 mm #4	2.36 mm #8	1.18 mm #16
CA 20	100	92 ± 8	20 ± 10	5 ± 5	3 ± 3

1004.03 Coarse Aggregate for Hot-Mix Asphalt (HMA). Revise the first line of the table in subparagraph (c) of Article 1004.03 to read:

Use	Size/Application	Gradation No.
Class A-1, 2, & 3	3/8 in. (10 mm) Seal	CA 20 ^{3/}

Add the following note to the end of subparagraph (c) of Article 1004.03:

"3/ CA16 or CM16 produced under the AGCS Program with a master band may be used if it meets the gradation requirements specified for CA20 in Article 1004.01(c)"

Amend the Aggregate Gradation Control System (AGCS) Policy Memorandum to add the following:

"CA 20 shall be produced under the AGCS program. However, the gradation bands may not be adjusted."

State of Illinois
DEPARTMENT OF TRANSPORTATION
Bureau of Local Roads & Streets

SPECIAL PROVISION
FOR
EMULSIFIED ASPHALTS

Effective: January 1, 2007
Revised: February 7, 2008

All references to Sections and Articles in this Special Provision shall be construed to mean specific Sections and Articles in the Standard Specifications for Road and Bridge Construction adopted by the Department of Transportation.

Replace the table after Note 2 in Article 403.02 with the following:

Type of Construction	Bituminous Materials Recommended for Weather Conditions Indicated	
	Warm [15 °C to 30 °C]* [(60 °F to 85 °F)]*	Hot [30 °C Plus]* [(85 °F Plus)]*
Prime	MC-30, PEP	MC-30, PEP
Cover Coat and Seal Coat	RS-2, CRS-2, RC-800, RC-3000, MC-800, MC-3000, SC-3000, HFE-90, HFE-150, HFE-300, HFRS-2, PEA**	RS-2, CRS-2, RC-800, RC-3000, MC-800, MC-3000, SC-3000, PG46-28, PG52-28, HFE-90, HFE-150, HFE-300, HFRS-2, PEA**

* Temperature of the air in the shade at the time of application.

** PEA is only allowed on roads with low traffic volumes

Replace the table after Note 2 in Article 406.02 with the following:

Type of Construction	Bituminous Materials Recommended
Prime (tack) on Brick, Concrete, or Bituminous Bases (Note 3)	SS-1, SS-1h, CSS-1, CSS-1h, HFE-90, RC-70
Prime on Aggregate Bases (Note 4)	MC-30, PEP
Mixture for Cracks, Joints, and Flangeways	PG58-22, PG64-22

Note 3. When emulsified asphalts are used, they shall be diluted with an equal volume of potable water. HFE emulsions shall be diluted by the manufacturer. The diluted material shall be thoroughly agitated within 24 hours of application and show no separation of water and emulsion. The diluted material shall not be returned to an approved emulsion storage tank.

Note 4. Preparation of the bituminous PEP shall be as specified in Article 403.05.

Replace the table in Article 1032.04 with the following:

Spraying Application Temperature Ranges		
Type and Grade of Bituminous Material	Temperature Ranges	
	°F min. - max.	°C min. - max.
PEP	60 - 130	15 - 55
PEA	140 - 190	60 - 88
MC-30	85 - 190	30 - 90
MC-70, RC-70, SC-70	120 - 225	50 - 105
MC-250, SC-250	165 - 270	75 - 130
MC-800, SC-800	200 - 305	95 - 150
MC-3000, SC-3000	230 - 345	110 - 175
PG46-28	275 - 385	135 - 195
PG52-28	285 - 395	140 - 200
RS-2, CRS-2	110 - 160	45 - 70
SS-1, SS-1h, CSS-1, CSS-1h	75 - 130	25 - 55
SS-1hP, CSS-1hP	75 - 130	25 - 55
HFE-90, HFE-150, HFE-300	150 - 180	65 - 80
HFP, CRSP, HFRS-2	150 - 180	65 - 80
E-2	85 - 190	30 - 90
E-3	120 - 225	50 - 105
E-4	165 - 270	75 - 130

Add subparagraph (g) to Article 1032.06:

- (g) Penetrating Emulsified Asphalt (PEA). The penetrating emulsified asphalt shall meet the following requirements when tested according to AASHTO T59:

Viscosity, Saybolt Fural @ 25°C (77°F),	sec:	20 - 500
Sieve Test, retained on 850 μm (No. 20) sieve, maximum,	%:	0.10
Storage Stability Test, 1 day, maximum,	%:	1
Float Test @ 60°C (140°F), minimum,	sec:	150
Stone Coating Test, 3 minutes,	:	Stone Coated Thoroughly
Particle Charge	:	Negative
pH, minimum	:	7.3
Distillation Test:		
Distillation to 260°C (500°F) Residue, minimum	%:	65
Oil Distillate by Volume, maximum	%:	3
Test on residue from distillation:		
Penetration @ 25°C (77°F), 100 g, 5 sec, minimum	dmm:	300

Replace the last sentence and table of Article 1032.06 with the following:

The different grades are, in general, used for the following.

Grade	Use
SS-1, SS-1h, CSS-1, CSS-1h, HFE 90, SS-1hP, CSS-1hP	Tack or fog seal
PEP	Bituminous surface treatment prime
RS-2, HFE 90, HFE 150, HFE 300, CRSP, HFP, CRS-2, HFRS-2, PEA	Bituminous surface treatment
CSS-1h Latex Modified	Microsurfacing

HERITAGE LAKE SUBDIVISION SPECIAL SERVICE AREA T24N, R2W 2026 SEAL COAT

	A-1
	A-2
	A-3

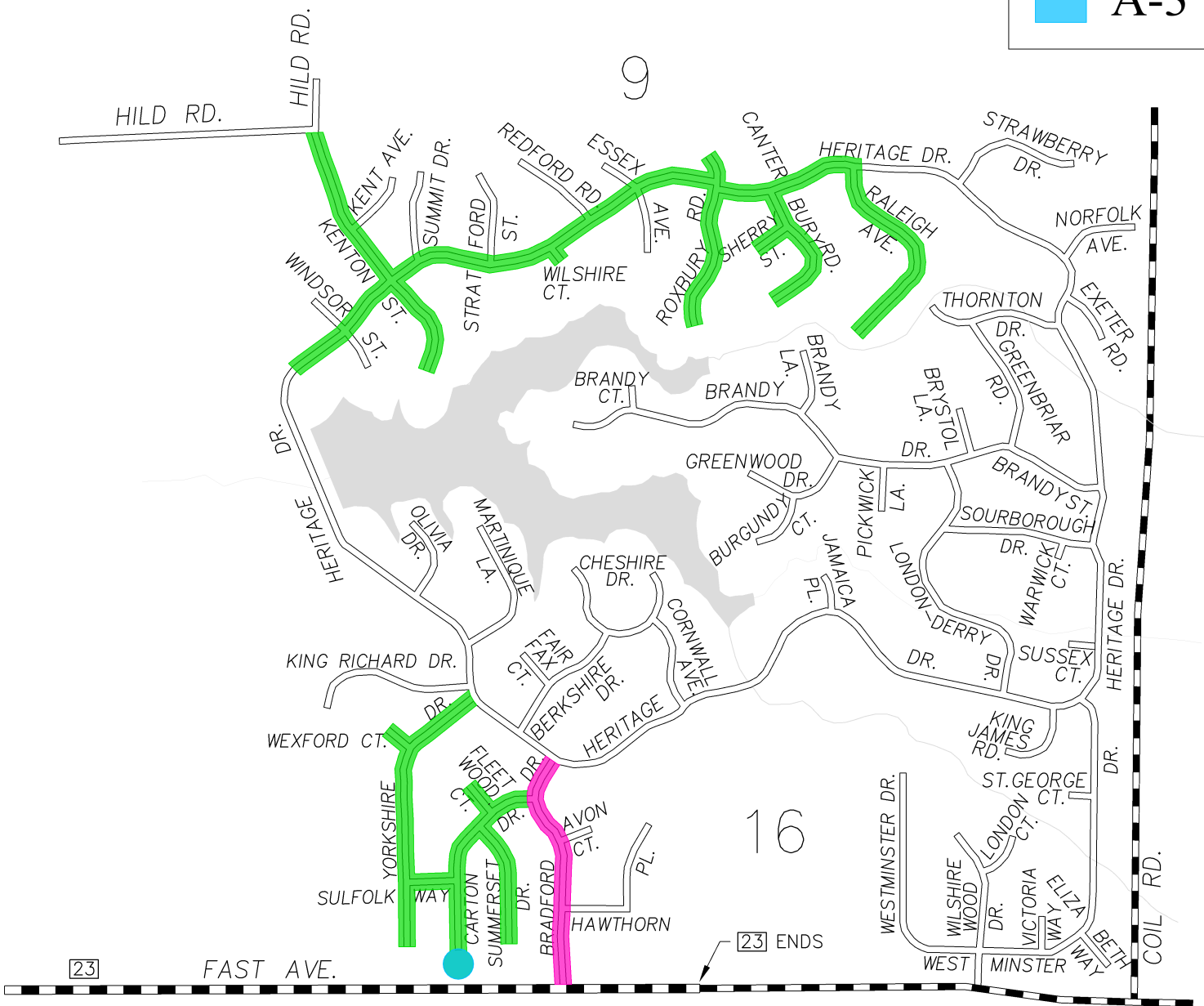

Quantities

A-1 & A-2				Cover Coat	Seal Coat	Cover Coat	Seal Coat
				CRS-2P	CRS-2P	Black Diabase	Black Diabase
				Tons	Tons	CA-16	CA-16
<u>Route/Section</u>	<u>Length (FT)</u>	<u>Width (FT)</u>	<u>Area (SQYD)</u>	<u>Tons</u>	<u>Tons</u>	<u>Tons</u>	<u>Tons</u>
*Heritage Drive	4,600	21	10,733		20		145
*Raleigh Ave	1,354	20	3,370		6		45
*Canterbury Rd	912	20	2,461		5		33
*Sherry St	240	20-24	743		1		10
*Roxbury Rd "NB"	180	20	706		1		10
*Roxbury Rd "SB"	1,062	20-22	2,881		5		39
*Wilshire Ct	150	20	666		1		9
*Kenton St "NB"	1,195	24	3,421		6		46
*Kenton St "SB"	750	20	2,069		4		28
*Bradford Ave	1,515	24-48	5,272	10	10	71	71
*Carlton Dr	1,330	21-26	3,525		7		48
*Fleetwood Ct	260	20	868		2		12
*Summerset Dr	935	20	2,585		5		35
*Suffolk Way	335	21	1,073		2		14
*Wexford Ct	220	20	870		2		12
*Yorkshire Dr	1,960	20	<u>4,676</u>		9		63
				45,919			

A-3		Cover Coat	Cover Coat
		CRS-2P	Black Diabase
		Tons	CA-16
<u>Route/Section</u>	<u>Area (SQYD)</u>	<u>Tons</u>	<u>Tons</u>
**Carlton Dr	491	2	13

*All Routes include intersection Radii

*All Quantities are "Furnished and Applied"

**Cul De Sac only, Seal coat application is included in A-1 QTY

Polymerized Bituminous Materials, Covers & Seal Coats (CRS-2P)

97 TON

Rate= 0.44 GAL/SQYD

Cover & Seal Coat Aggregate (Black Diabase CA-16)

704 TON

Rate= 27 POUND/SQYD

Traffic Control & Protection (Special)

1 Lump Sum

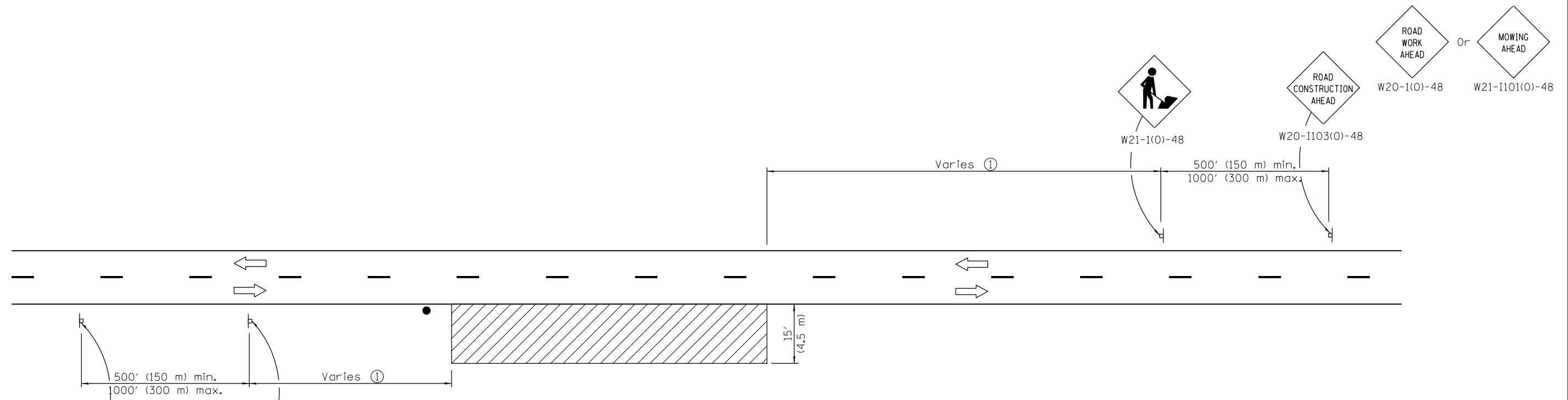

For entire Project

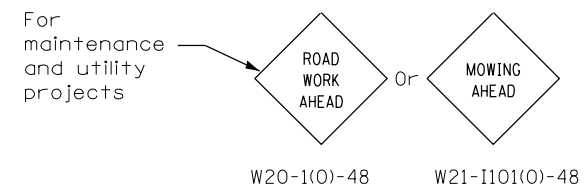
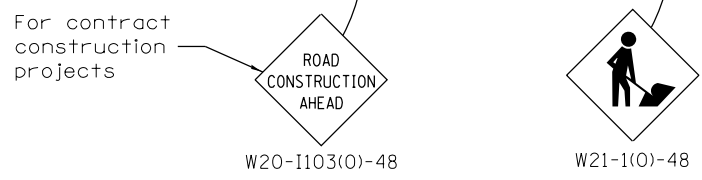

TYPICAL APPLICATIONS
Shoulder work
Utility operations

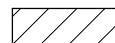

SYMBOLS

-  Work area
-  Sign
-  Flagger with traffic control sign when required

① Minimum distance is 200' (60 m). Maximum distance to be determined by the Engineer but should not exceed 1/2 the length required for one normal working day's operation, or 4 miles (6.4 km) whichever is less.

GENERAL NOTES

This Standard is used where at any time, any vehicle, equipment, workers or their activities require an intermittent or continuous moving operation on the shoulder, where the average speed is 1 mph (2 km/h) or less.

When the work operation does not exceed 60 minutes, traffic control may be according to Standard 701301.

All dimensions are in inches (millimeters) unless otherwise shown.

DATE	REVISIONS
1-1-14	Revised workers sign number to agree with current MUTCD.
1-1-13	Omitted text 'WORKERS' sign.

**OFF-RD MOVING OPERATIONS,
2L, 2W, DAY ONLY**

STANDARD 701011-04

Illinois Department of Transportation

APPROVED January 1, 2014
[Signature]
ENGINEER OF SAFETY ENGINEERING

APPROVED January 1, 2014
[Signature]
ENGINEER OF DESIGN AND ENVIRONMENT

ISSUED 1-1-97

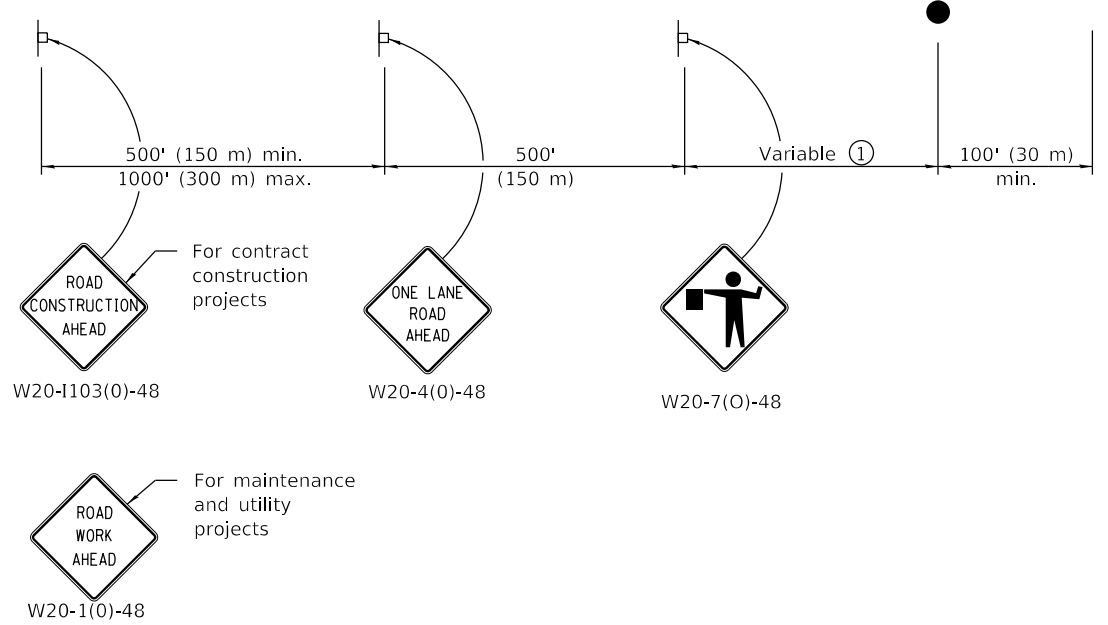
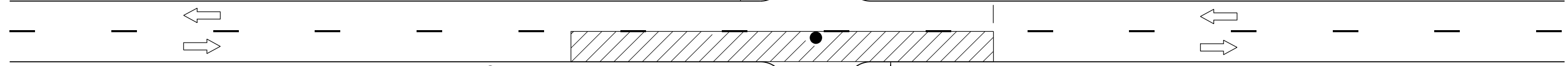
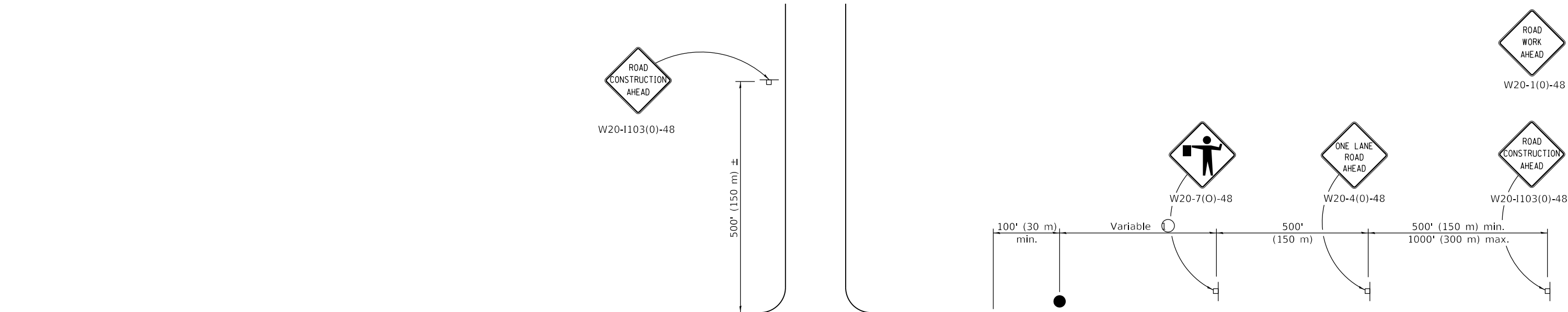

TYPICAL APPLICATIONS

- Bituminous resurfacing
- Milling operations
- Utility operations
- Shoulder operations

SYMBOLS

- Work area
- Sign on portable or permanent support
- Flagger with traffic control sign

① Minimum distance is 200' (60 m). Maximum distance to be determined by the Engineer but should not exceed ½ the length required for one normal working day's operation or 2 miles (3200 m), whichever is less.

GENERAL NOTES

This Standard is used where at any time, any vehicle, equipment, workers or their activities require an intermittent or continuous moving operation on the pavement where the average speed of movement is greater than ½ mph (1 km/h) and less than 4 mph (6 km/h).

When the operation does not exceed 60 minutes, traffic control may be according to Standard 701301.

All dimensions are in inches (millimeters) unless otherwise shown.

DATE	REVISIONS
1-1-18	Revised lower speed limit for operation to ½ mph.
1-1-11	Revised flagger sign.

LANE CLOSURE, 2L, 2W, SLOW MOVING OPERATIONS DAY ONLY, FOR SPEEDS ≥ 45 MPH

STANDARD 701306-04

Illinois Department of Transportation

PASSED January 1, 2018

 ENGINEER OF SAFETY PROG. AND ENGINEERING

APPROVED January 1, 2018

 ENGINEER OF DESIGN AND ENVIRONMENT

ISSUED 1-1-97

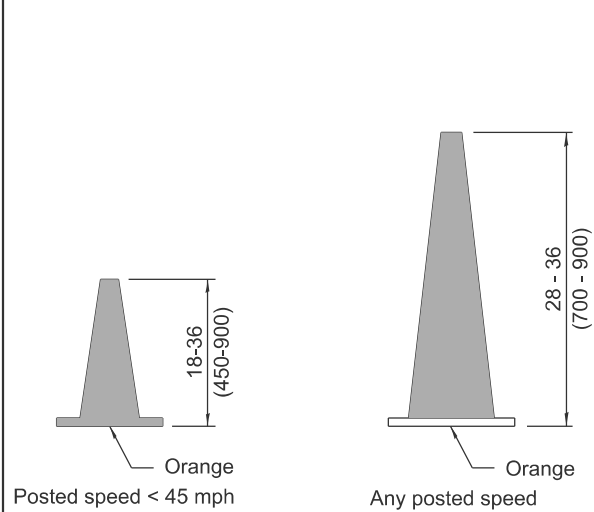

DAYTIME USE

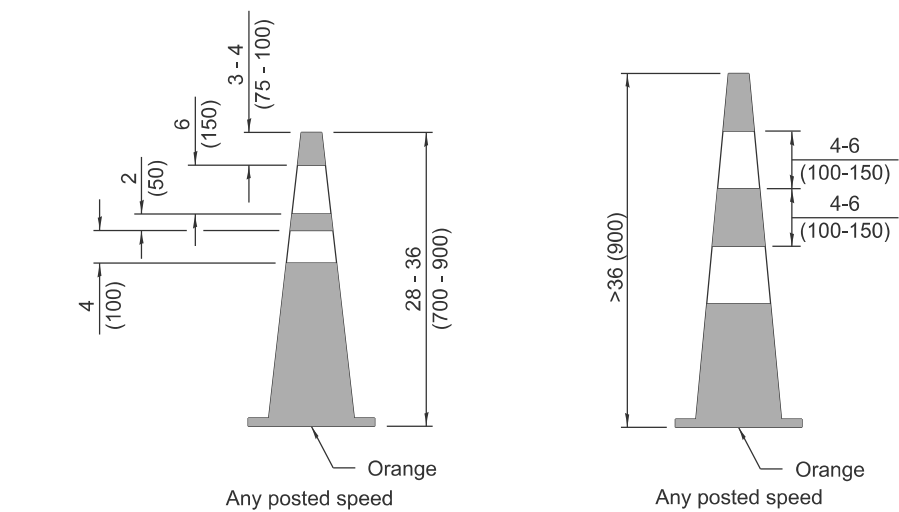

DAY OR NIGHTTIME USE

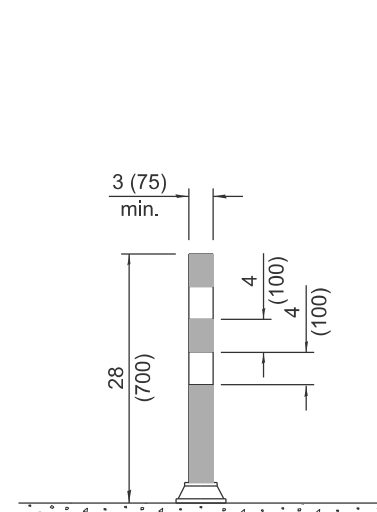

TUBULAR MARKER

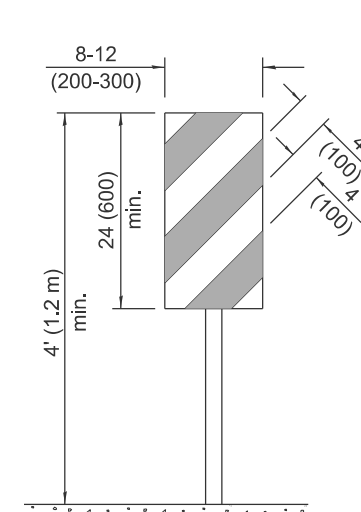

**VERTICAL PANEL
POST MOUNTED**

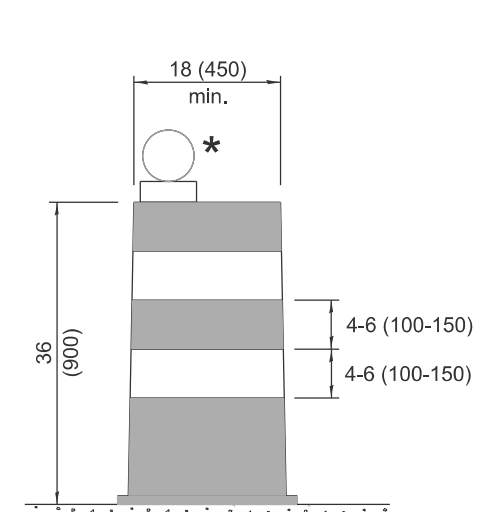

DRUM

CONES

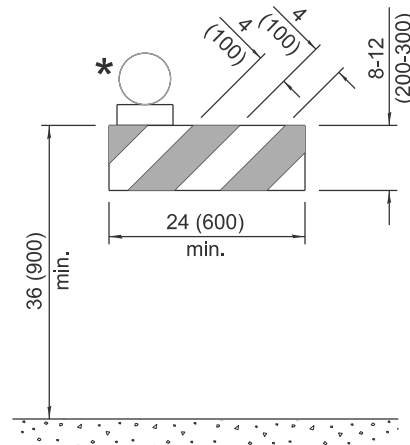

TYPE I BARRICADE

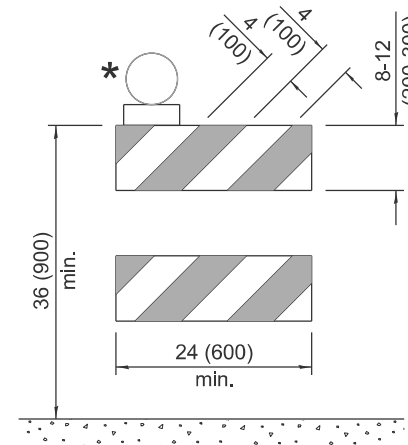

TYPE II BARRICADE

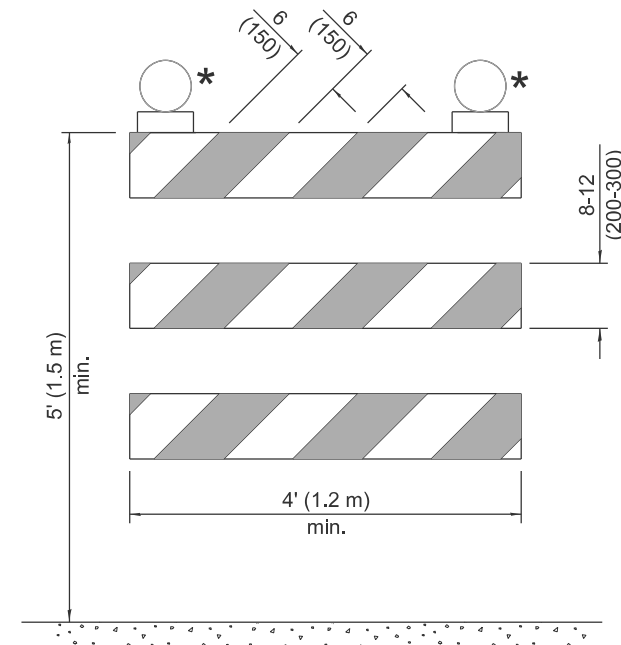

TYPE III BARRICADE

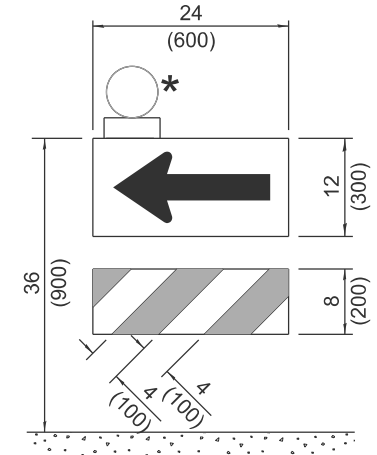

**DIRECTION INDICATOR
BARRICADE**

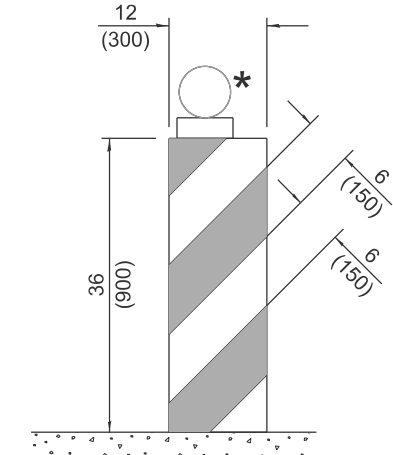

VERTICAL BARRICADE

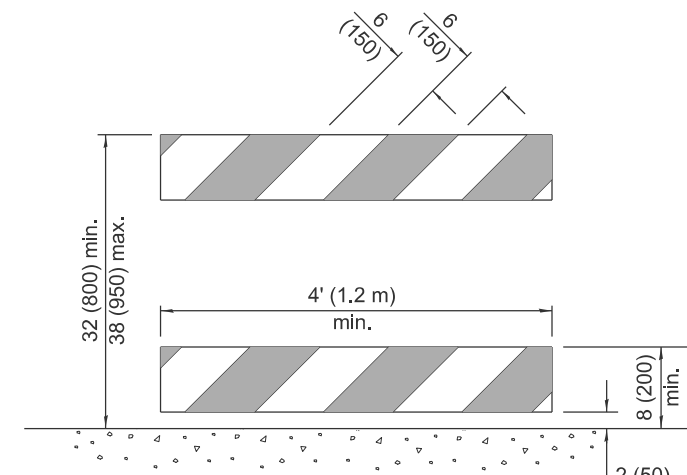

**DETECTABLE PEDESTRIAN
CHANNELIZING BARRICADE**

* Warning lights (if required)

GENERAL NOTES

All heights shown shall be measured above the pavement surface.

All dimensions are in inches (millimeters) unless otherwise shown.

Illinois Department of Transportation

APPROVED January 1, 2026
ENGINEER OF SAFETY PROG. AND ENGINEERING

APPROVED January 1, 2026
ENGINEER OF DESIGN AND ENVIRONMENT

ISSUED 1-1-13

DATE	REVISIONS
1-1-26	Updated Detectable Pedestrian Channelizing Barricade (sht. 1) & Temporary Rumble Strips details (sht. 3)
1-1-25	Updated Temporary Rumble Strip Detail (sht. 3).

TRAFFIC CONTROL DEVICES

(Sheet 1 of 3)

STANDARD 701901-11

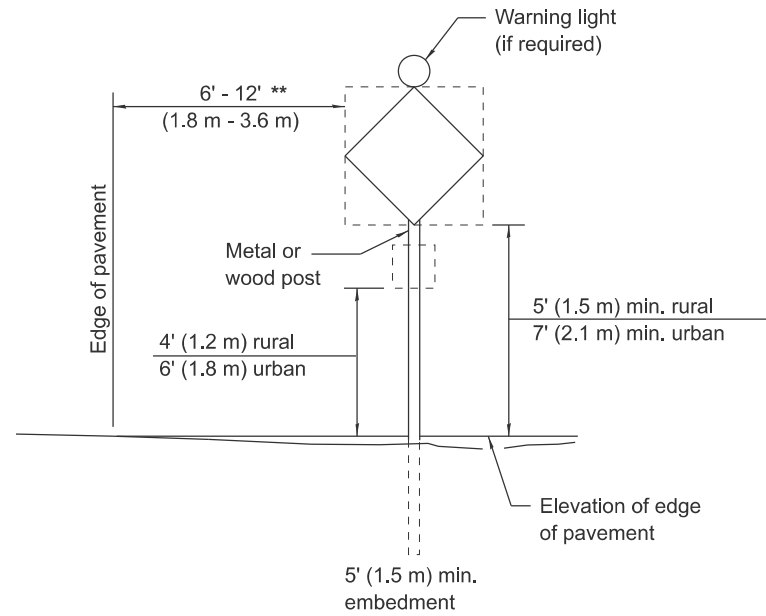

POST MOUNTED SIGNS

** When curb or paved shoulder are present this dimension shall be 24 (600) to the face of curb or 6' (1.8 m) to the outside edge of the paved shoulder.



W12-1103-4848

WIDTH RESTRICTION SIGN

XX'-XX" width and X miles are variable.

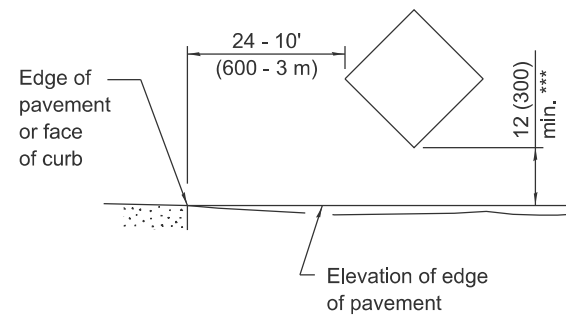

SIGNS ON TEMPORARY SUPPORTS

*** When work operations exceed four days, this dimension shall be 5' (1.5 m) min. If located behind other devices, the height shall be sufficient to be seen completely above the devices.

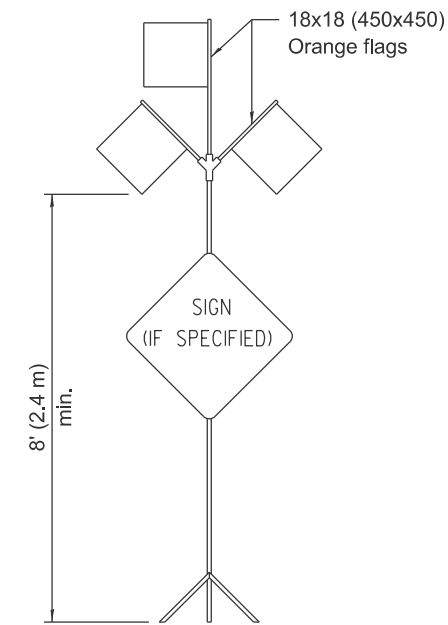

HIGH LEVEL WARNING DEVICE

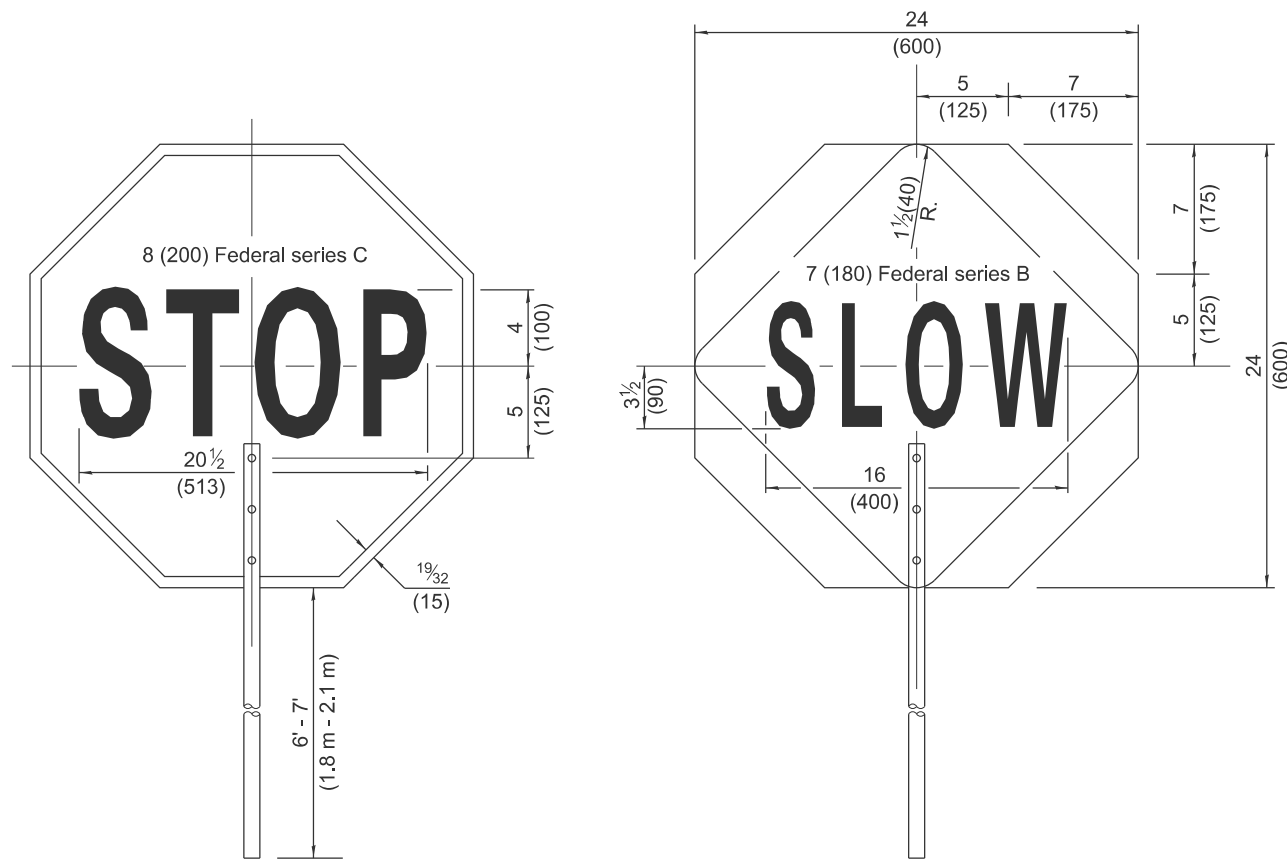

FRONT SIDE

REVERSE SIDE

FLAGGER TRAFFIC CONTROL SIGN



G20-1104(0)-6036



G20-1105(0)-6024

This signing is required for all projects 2 miles (3200 m) or more in length.

ROAD CONSTRUCTION NEXT X MILES sign shall be placed 500' (150 m) in advance of project limits.

END CONSTRUCTION sign shall be erected at the end of the job unless another job is within 2 miles (3200 m).

Dual sign displays shall be utilized on multi-lane highways.

WORK LIMIT SIGNING

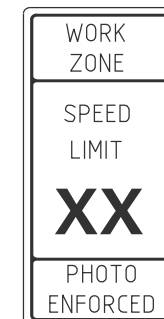

W21-1115(0)-3618

R2-1-3648

R10-1108p-3618 ****



R2-1106p-3618

Sign assembly as shown on Standards or as allowed by District Operations.

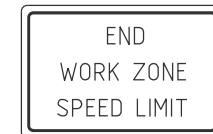

G20-1103-6036

This sign shall be used when the above sign assembly is used.

HIGHWAY CONSTRUCTION SPEED ZONE SIGNS

**** R10-1108p shall only be used along roadways under the jurisdiction of the State.

TRAFFIC CONTROL DEVICES

(Sheet 2 of 3)

STANDARD 701901-11

Illinois Department of Transportation

APPROVED January 1, 2026
ENGINEER OF SAFETY PROG. AND ENGINEERING

APPROVED January 1, 2026
ENGINEER OF DESIGN AND ENVIRONMENT

ISSUED 1-1-13

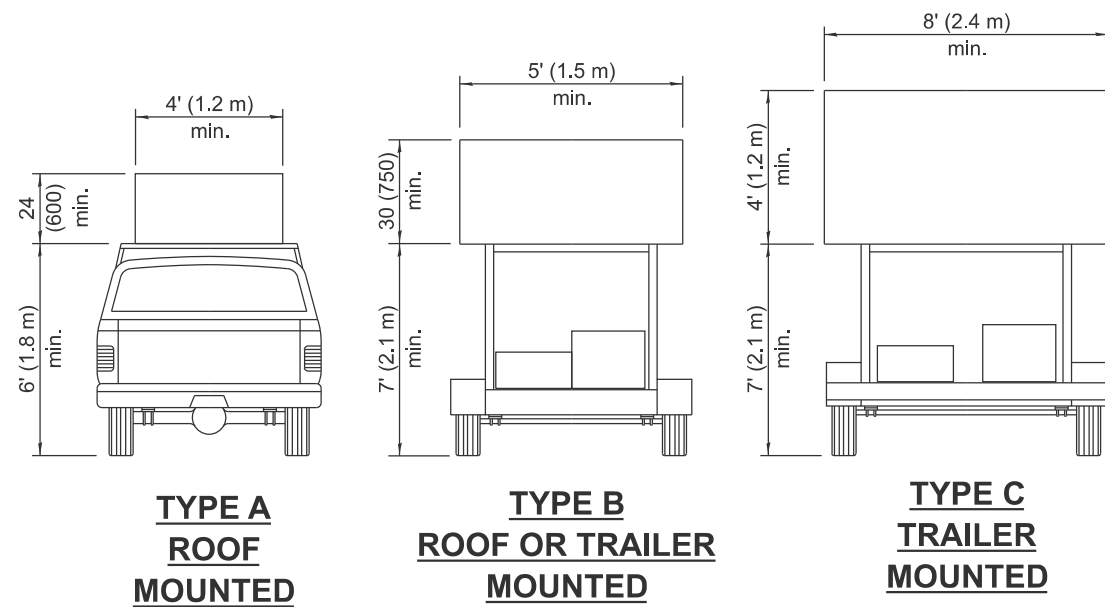

ARROW BOARDS

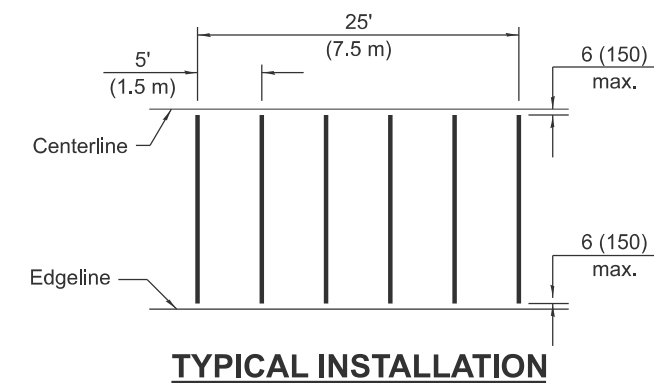
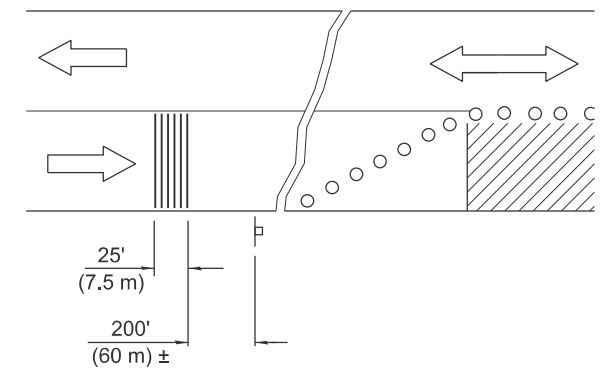
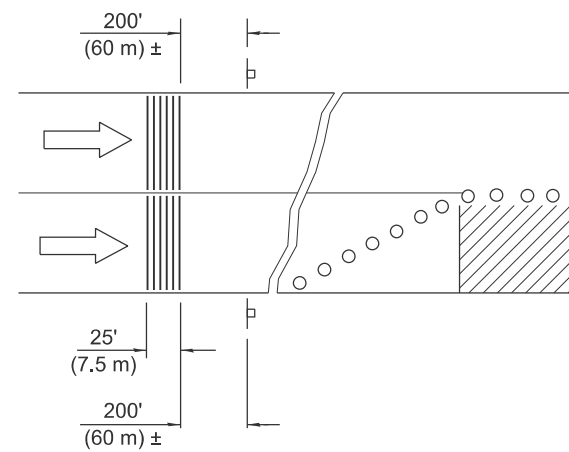

TEMPORARY RUMBLE STRIPS

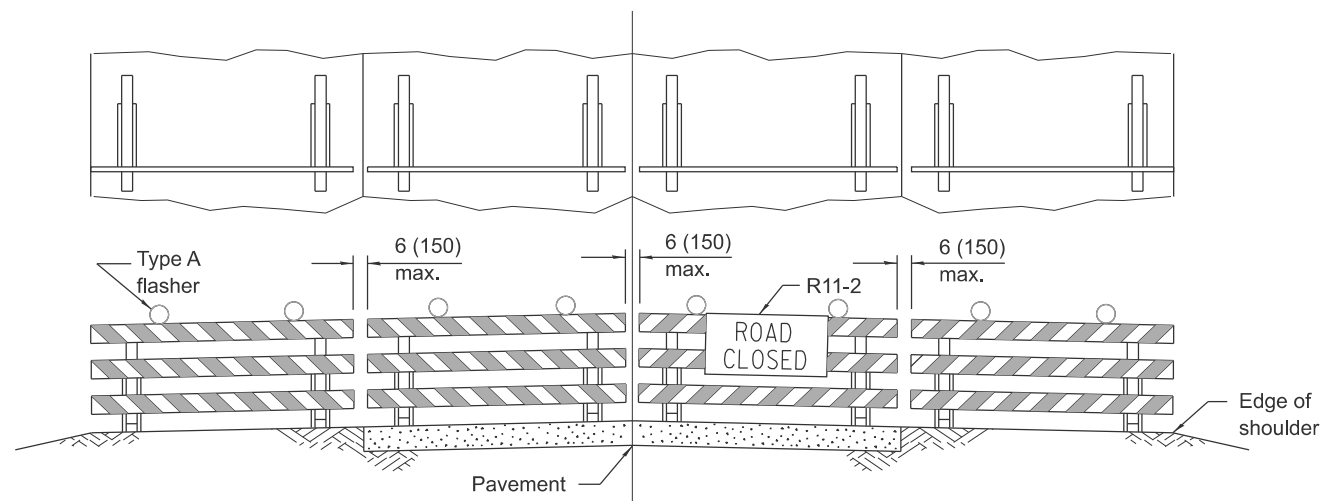

Reflectorized striping may be omitted on the back side of the barricades.

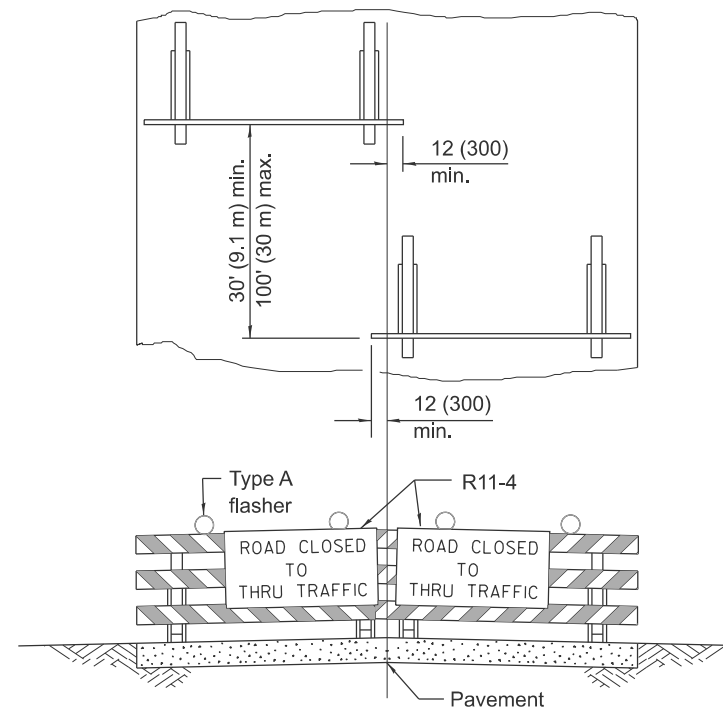

Reflectorized striping shall appear on both sides of the barricades.

**TYPICAL APPLICATIONS OF
TYPE III BARRICADES CLOSING A ROAD**

If a Type III barricade with an attached sign panel which meets NCHRP 350 or MASH is not available, the sign may be mounted on an NCHRP 350 or MASH temporary sign support directly in front of the barricade.

**TRAFFIC CONTROL
DEVICES**

(Sheet 3 of 3)

STANDARD 701901-11

Illinois Department of Transportation

APPROVED January 1, 2026

ENGINEER OF SAFETY PROG. AND ENGINEERING

APPROVED January 1, 2026

ENGINEER OF DESIGN AND ENVIRONMENT

ISSUED 1-1-13